

Owners Manual

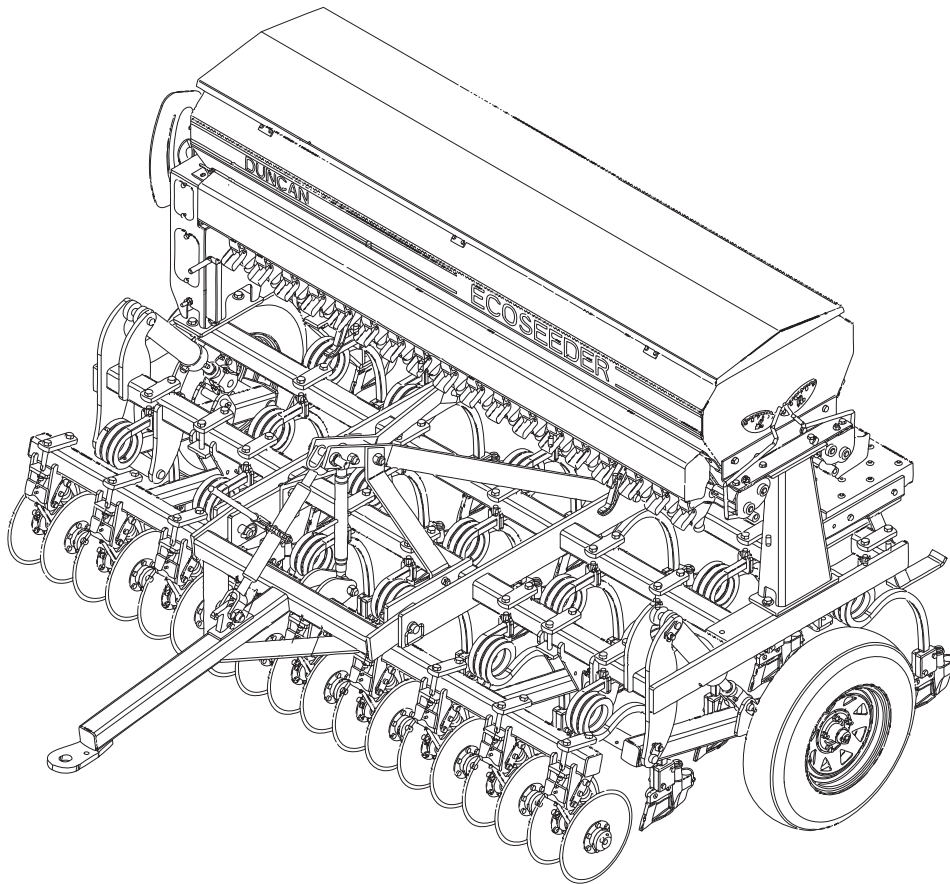

EcoSeeder ORIGINAL INSTRUCTIONS



Built to work.

Head Office:
P.O. Box 2018
Hilton Highway, Washdyke
Timaru, New Zealand
Telephone (03) 688 2029
Facsimile (03) 688 2821

Australian Branch:
4B Silverton Close
Laverton North 3026
Melbourne, Australia
Telephone (03) 9314-9666
Facsimile (03) 9314-6810

**Pt. No. 67392
Issue 0918**

EcoSeeder Contents

	Page
Introduction	2
Acquisition & Warranty	2
Disclaimer	2
Description of Machine Working Principle.....	3
Dimensions & Capacities	5
SAFETY - General	
Safety Symbols on Machine	6
Operator Safety	7
Be Prepared for Emergencies.....	7
Appropriate Dress	8
Transport This Machine Safely	8
Handle Agricultural Chemicals Safely.....	9
Avoid High Pressure Fluids.....	9
Safe Work Practices	9
Practise Safe Maintenance	10
SAFETY - Machine Specific	
Hazard Points	11
Safety Decals & Safety Guards.....	13
Transport	14
Operation	15
Sowing Chart	17
Basic Calibration Procedure	
Gearbox Setting Lever	18
Setting Seeder Shutter Slides	18
Bottom Flap Settings.....	18
Seed Calibration	19
Hand Crank Turns for Seed Rate Calculation.....	20
Use of Seed Rate Calculator.....	21
Calibration Deviations	22
Sowing of Fine Seeds	23
Sowing Small Seeds	24
Sowing Peas	24
Hectaremeter Settings.....	25
Calibration Notes.....	27
Maintenance & Care	
General	28
Lubrication Instructions	29
Maintenance Schedule	30
Storage	32
Troubleshooting/Maintenance Notes.....	33
Calibration Chart and Handy Hints	34
<i>(copies of chart that may be found inside box lid)</i>	
Parts List	
Base Machine	39
Optional Extras	69

Introduction

Acquisition & Warranty

On delivery of your new Duncan EcoSeeder please check that the machine is not damaged. In cases of shipping damage, please ask your dealer to arrange for the appropriate claim to be lodged immediately. Assemble any parts supplied loose and inspect your machine with the aid of this manual to familiarise yourself with its features. If you have any queries ask your dealer straight away. The machine is covered by our 12 month warranty on faulty parts, subject to normal use.



Record below the serial number of your machine and keep it in a secure place to help trace the machine and assist us when you order parts.

Model:
Serial No:
Owner:
.....
.....
Delivery Date:
Dealer:
.....
.....

This Document contains the Original Operating Instructions for this machine and are verified by the Manufacturer, Signed:..... Product Development Manager
--

The Owner's Manual

Your new Duncan EcoSeeder will give long and efficient service if given normal care and operated properly.

This owner's manual is provided so that you can become thoroughly familiar with the design of the machine and to furnish information on correct operation, adjustment and maintenance. **Only persons well acquainted with these guidelines should be allowed to use the equipment.**

A separate illustrated parts section has been provided so that if any parts are required your dealer will be able to supply them by reference to part numbers.

The manual is considered as part of your machine and must remain with the machine when it is sold.

Right and left hand references in this manual are determined by standing behind the machine and facing in the direction of travel.

Disclaimer Every effort has been made to ensure that the information in this manual was accurate and up to date at the time of going to press. Clough Agriculture reserves the right to make subsequent changes to the machine, where necessary, without notification. The Company will not be responsible for any damage or consequential loss arising out of misinterpretation or failure to follow recommended procedures. Nor will it be liable for any damage caused by or arising out of modification or misuse of its product. The owner has a responsibility to protect himself and others by observing all safety information and by ensuring all operators are well acquainted with the safety information, trained in the correct use of the machine and applying safe work practices.
--



Description of Machine

The Duncan EcoSeeder is a Tee-boot drill which can be operated as a trailing or a 3 point linkage machine. The seed box is mounted on a robust frame accommodating large diameter tyres for the arable situation. The depth of the ground engaging components on the 3 point linkage machine is controlled by adjusting turnbuckles fitted to each wheel leg. For the trailing machine, the depth is controlled by using the hydraulic rams and depth control collars on each ram. The quality European type peg roller seeder system handles all seeds from turnip and rape through to peas and maize. The seeders are driven from one of the groundwheels via a jockey wheel system and variable speed gearbox. For transport the drive is easily disconnected by raising the drill to its transport height.

Working Principle

The gearbox, pegged seed rollers and seeder flaps are set to give the desired seed rate. The coil tine and T-boot, create the seed bed. Seed flows down the flexible tubes between seeder and tee-boot units, and drops into the prepared seed bed.

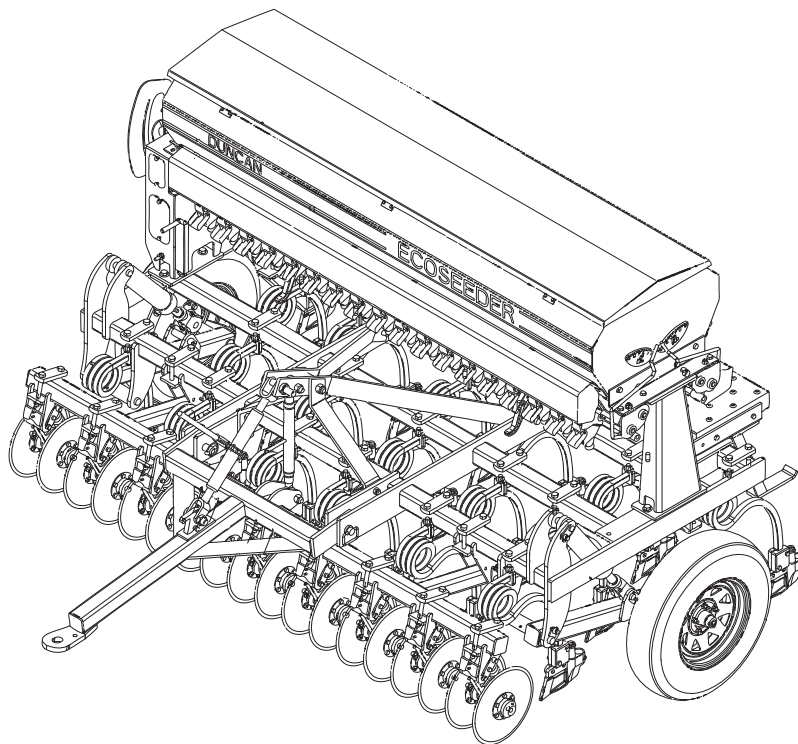

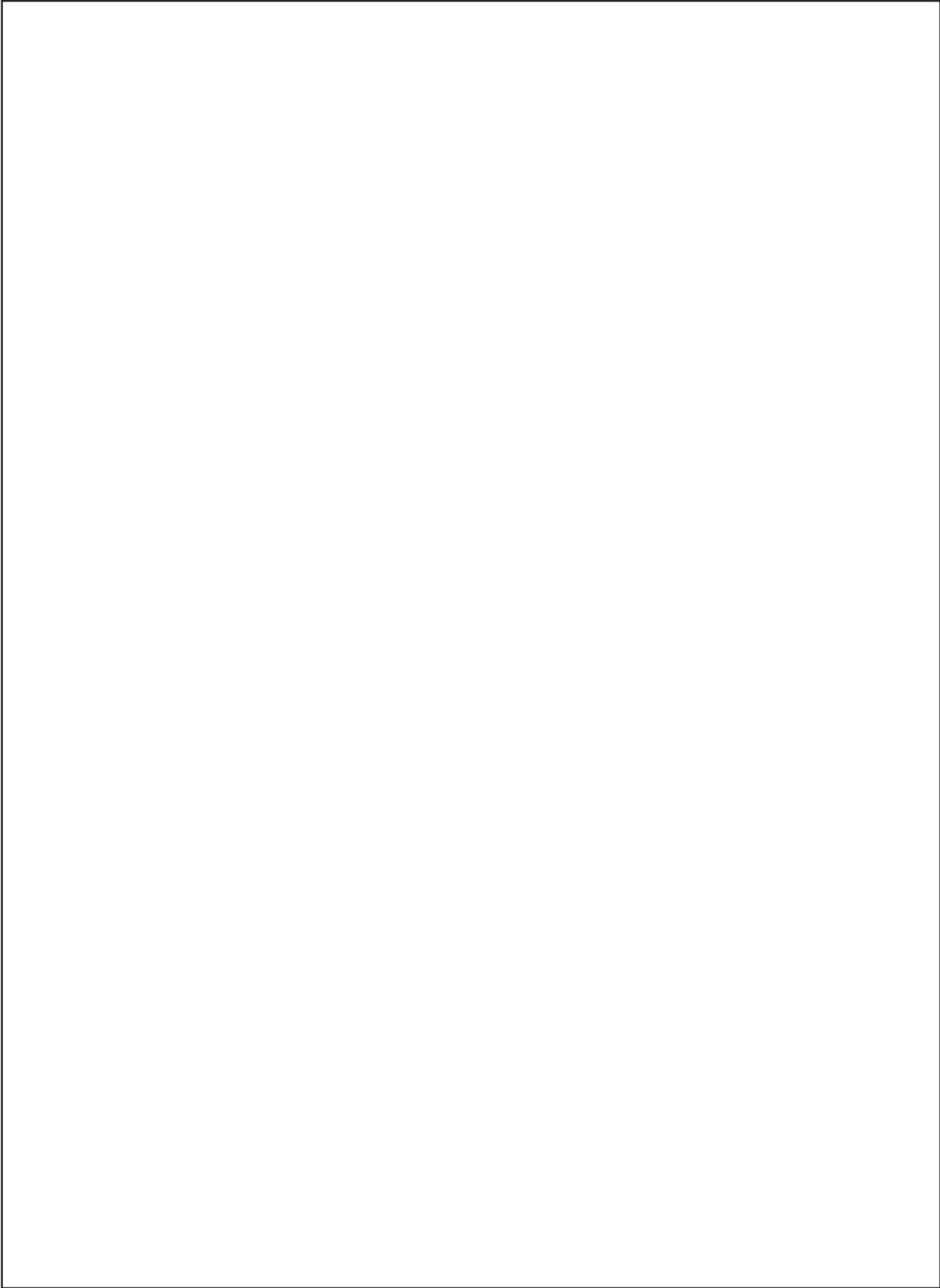

Dimensions & Capacities		14 Run				16 Run				18 Run			
Description	S/B 3PL	S/B Trailing	S/B 3PL	D/B Trailing	D/B 3PL	S/B Trailing	S/B 3PL	D/B Trailing	D/B 3PL	S/B Trailing	S/B 3PL	D/B Trailing	D/B 3PL
Sowing Width (mm)	2079		2376			2673							2673
Width (over wheels /mm)	2698		2995										
Height (Groundwheels up /mm)			1623										
Height (Groundwheels down /mm)			2000										
Row Spacing (mm)			148.5										
Weight inc. disc openers (kg)	731*	1050	998	1150	1098	1130	1078	1256	1204				
Box Capacity (litres per box)	295	338	338	326	326	338	338	326	326				
Overall Length (mm)	1685**	2720	1551	2870	1702	2856	1687	2870	1702				
Tyre Size	ST215/75D14												
Recommended Tyre Pressure	2.76 bar (40psi)												
Maximum speed	40km/hr												
Jockey Tyre Size	410/350 x 6 x 4 ply												
Jockey Tyre Pressure***	3.44 bar (50 psi) - TYRE IS FILLED WITH ANTI-PUNCTURE SEALANT***												
	S/B 3PL	S/B Trailing	S/B 3PL	D/B Trailing	D/B 3PL	S/B Trailing	S/B 3PL	D/B Trailing	D/B 3PL	S/B Trailing	S/B 3PL	D/B Trailing	D/B 3PL
	14 Run	16 Run				18 Run				18 Run			

* No disc openers fitted

** Length to linkage as no drawbar fitted

***Pressure gauges may be damaged if they are not filtered

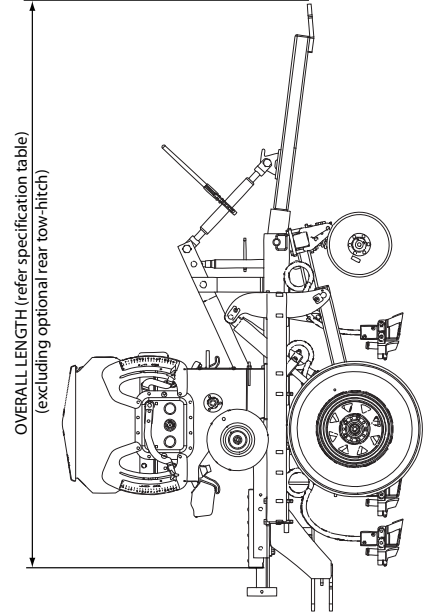
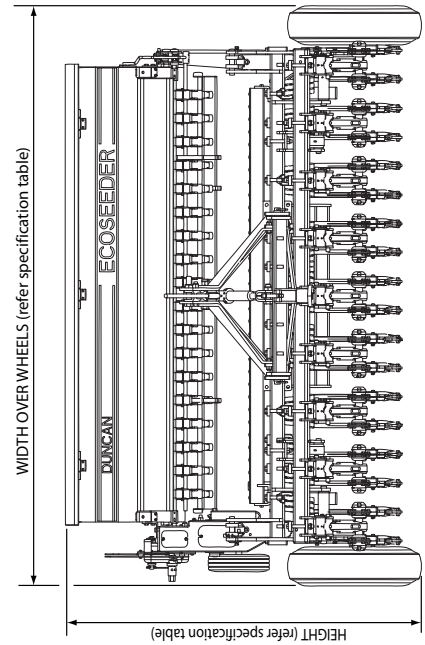

Dimensions & Capacities



ATTENTION

On the machine important safety information is indicated by these symbols. These highlight general safety aspects in regard to the machine rather than specific hazards.



NO RIDE

Do not ride or allow passengers on the machine.

Under no circumstances are passengers to be permitted on the machine while it is in operation or being transported. Any footboards and/or footsteps are provided solely for the purpose of preparing the machine for use.



**Pinch Points
Moving Parts**

Keep clothing and body extremities well clear of pinch points while the machine is operating (seeding or calibrating). Keep well clear of moving parts at all times.

These signs typically occur wherever trapping points exist. These include drive chains, sprockets, shafts, wheels, discs, pivot points, etc. Guards are provided with the machine for safety reasons (where practical without compromising machine performance). Ensure these are always fitted during operation.



**Sharp
Points**

Always exercise extreme caution in the vicinity of sharp edges and points.

Where possible guards are provided with the machine for safety reasons (where practical without compromising machine performance). Ensure these are always fitted during operation.



**Slippery
When
Wet**

Footboards, footsteps, drawbars and other machine surfaces may be slippery when wet.

Apply extra caution in wet conditions and in the early morning when surfaces are wet.

KEEP CLEAR

Keep Clear. (It is dangerous to be in this area when the machine is operating.)

SAFETY - General

N.B. Throughout this manual important safety information is indicated by these symbols in the margin:



A prohibition should be observed under all circumstances.



A warning indicates a hazard that could cause death or injury if the warning is ignored.



A caution indicates a hazard that may cause damage to property if the caution is ignored.

This section of the manual offers general guidelines for the safe operation of machinery. It does not replace local safety regulations. These guidelines were current at the time of publication, but may be superseded by later regulations.

Clough Agriculture has made every effort to highlight all risks to personnel or property. Owners and operators have a responsibility to exercise care and safe work practices at all times in the vicinity of the machine.

Owners are advised to keep up to date on safety issues and to communicate these to all users of the machine.

Contact the Occupational Safety and Health Service (OSH) for further information about general safety aspects. If you have safety concerns specifically related to this machine, contact your dealer immediately.

Operator Safety

Read this manual carefully before operating new equipment. Learn how to use this machine safely. Be thoroughly familiar with the controls and the proper use of the equipment before using it.



Take careful note of all safety instructions both in this manual and on the machine itself. Failure to comply with instructions could result in personal injury and/or damage to the machine.

Replace missing or damaged safety signs on the machine and ensure that these remain clearly visible.

It is the owner's responsibility to ensure that anyone who operates, adjusts, lubricates, maintains, cleans or uses the machine in any way has had suitable instruction and is familiar with the information in this manual (particularly with regard to safety aspects).

Operators and other users of the machine should be aware of potential hazards and operating limitations.



Be Prepared for Emergencies

Keep a first aid kit and fire extinguisher handy.

Keep emergency numbers for doctors, ambulance, hospital and fire department near your telephone.



SAFETY - General (Continued)



Appropriate Dress

Wear close fitting clothing and avoid rings or other forms of jewellery which could become caught in the machinery.

People with long hair must have it securely fixed and confined close to the head.

Refer to local safety standards for protective clothing and recommended safety equipment.

Adequate protection, such as a face mask, should be worn if operating this machine in dry and dusty conditions.



Transport This Machine Safely

Ensure that all linkage pins and security clips are fitted correctly. With trailing machines tow with the drawbar only, as this is the only safe towing point on the machine.

Always check that bystanders (especially children) are well clear (front and rear) before starting and moving the tractor and the machine.

Plan safe routes of travel, and be aware of power lines and other roadside hazards. Take particular care when towing implements on hillsides.

Do not ride or allow passengers on the machine.

This machine is not designed to carry passengers, and no riders are permitted.



Road transport

On public roads,

- A speed of 40km/h must not be exceeded.
- Do not operate during the hours of darkness unless standard lights are fitted and clearly visible. (This also applies when visibility is limited, e.g., in foggy conditions.)

See the guidelines in the *Vehicle Dimensions and Mass Rule*, issued by the Land & Transport Safety Authority.

Avoid tip-overs

Avoid holes, ditches and obstructions which may cause the machine to tip over, especially on hillsides. Never drive near the edge of a gully or steep embankment - it might cave in. Slow down for hillsides, rough ground and sharp turns.



SAFETY - General (Continued)

Handle Agricultural Chemicals Safely

All farm chemicals should be stored, used, handled and disposed of safely and in accordance with the supplier's/manufacturer's recommendations.



Read the product label before using, noting any warnings or special cautions, including any protective clothing or equipment that may be required, ie. respirator.

Do not eat or smoke while handling sprays, fertilisers, coated seeds, etc. Afterwards, always wash your hands and face before you eat, drink, smoke, or use the toilet.



Store sprays, fertilisers, coated seeds, etc. out of reach of children and pets, and away from food and animal feeds.

Any symptoms of illness during or after using chemicals should be treated according to the supplier's/manufacturer's recommendations. If severe, **call a physician or get the patient to hospital immediately**. Keep the container and/or label for reference.

Avoid High Pressure Fluids

Avoid any contact with fluids leaking under pressure, because the fluids can penetrate the skin surface.



Any fluid which penetrates the skin, will need to be **removed immediately by a medical expert**. Seek specialist advice on this type of injury.



Relieve the pressure before disconnecting any hydraulic or other lines. Make all repairs and tighten all fittings before re-connection to pressurised fluid.

Keep your hands and body away from any pinholes or high pressure jets. Search for leaks with a piece of cardboard instead of using your hand directly.

Safe Work Practices

All farm machinery is potentially dangerous and should be treated with caution and respect.



Before starting the machine, ensure that all controls are placed in neutral and that bystanders are well clear. Check that the guards have been securely fitted and that any adjustments have been made correctly.

Where possible, disconnect or isolate the drive mechanism to the implement. Lower the machine onto the ground when not in use.

Do not operate this equipment when severe weather conditions appear imminent.

SAFETY - General (Continued)



Practise Safe Maintenance

Keep the machine in safe working condition. Routine maintenance and regular servicing will help reduce risks and prolong the life of the machine.

General Maintenance

Accidents occur most frequently during servicing and repair. The following general rules must be followed when maintaining or working with machinery:

- All operating and maintenance manuals must be read before and referred to while using or servicing any piece of equipment.
- Turn off all machinery power sources and isolate the machine before making adjustments, doing lubrication, repairs or any other maintenance on the machine.
- Ensure that the machine hydraulics are disconnected from the power source.
- Wear gloves when handling components with cutting edges, such as any ground cutting components.
- Beware of hazards created by springs under tension or compression when dismantling or maintaining the machine.
- It is recommended that you clean the machine with a water blaster or similar apparatus before commencing maintenance.

Make Sure the Machine is Well Supported

When machinery is fitted with hydraulics, do not rely on the hydraulics to support the machine. During maintenance or while making adjustments under the machine, always lock the hydraulics and support the machine securely. Place blocks or other stable supports under elevated parts before working on these.



Electrical Maintenance

Disconnect the electrical supply from the tractor before doing any electrical maintenance.



Welding

With electronic equipment in modern tractors it is advisable to disconnect the machine from the tractor, or at least disconnect the alternator and battery before attempting any welding.



Use Only Genuine Spare Parts

Unauthorised modifications or non-genuine spare parts may be hazardous and impair the safe operation and working life of the machine.

Excess lubricants must be disposed of safely so as not to become a hazard.

SAFETY - Machine Specific

This section of the manual gives specific guidelines for the safe operation of the EcoSeeder.

These guidelines were current at the time of publication, but may be superseded by later circumstances. They do not necessarily cover every possible hazard and must be read in conjunction with the **SAFETY - General** section (Page 6-10).

Hazard Points on the EcoSeeder

The lists below are not all-inclusive and serve only to highlight the more obvious areas of risk.



The decals attached to the machine are a general reminder that there are hazardous areas on the machine, rather than specifically highlighting all possible hazards.

For decal locations on machine, refer Page 13.



No Ride

Passengers are not permitted anywhere on the machine.



Pinch Points/Moving Parts

Hazardous areas include:

- Drive chains.
- Sprockets between the drive wheel, the transfer shaft and the gearbox (RH side).
- Sprockets between the gearbox and the box shafts (RH side).
- Agitator drive units (LH side).
- Agitator shaft inside the boxes.
- Seeder units, box shaft and shaft connectors.
- Wheel legs and main frame assemblies
- Between discs and other sub-assembly parts (where fitted).
- Finger tine assemblies (where fitted).



Slippery
When
Wet

Slippery When Wet

Hazardous areas include:

- Footboards and footstep.
- All smooth surfaces on the frame structure.



Keep Clear

Hazardous areas include:

- Between the tractor and EcoSeeder.
- Immediately adjacent to the EcoSeeder side.

SAFETY - Machine Specific (Continued)



Hazard Points on the EcoSeeder (Continued)

Pedestal Chain Guards

To prevent hands, etc. getting caught in drive chains, guards are provided to cover sprockets, chain and chain tensioners mounted about the drive pedestal (RHS). These guards must be fitted while using the machine.

Warning: Access to pinch points is still possible from underneath the guard.

For guard locations on machine, refer Page 13.

Calibrating

Be particularly careful when calibrating the seeding rate. At this time, the calibration trays have been removed and are no longer covering the rotating seeder units. See **Pinch Points/ Moving Parts** (Page 11) for hazardous areas.

Transport

The two wheels located at the sides of the machine are for the purpose of controlling sowing depth. These are also used to support the machine weight during transport (while linked to the tractor).



Important - Refer to safety cautions in the **Transport** section, page 8 of the manual. Ensure that all linkage pins and security clips are fitted correctly.

Maintenance

Refer Page 28 for reference to the **Maintenance and Care** section of the manual.

Lubrication

Refer Page 29 for reference to the **Maintenance and Care** section of the manual.

SAFETY - Machine Specific (Continued)

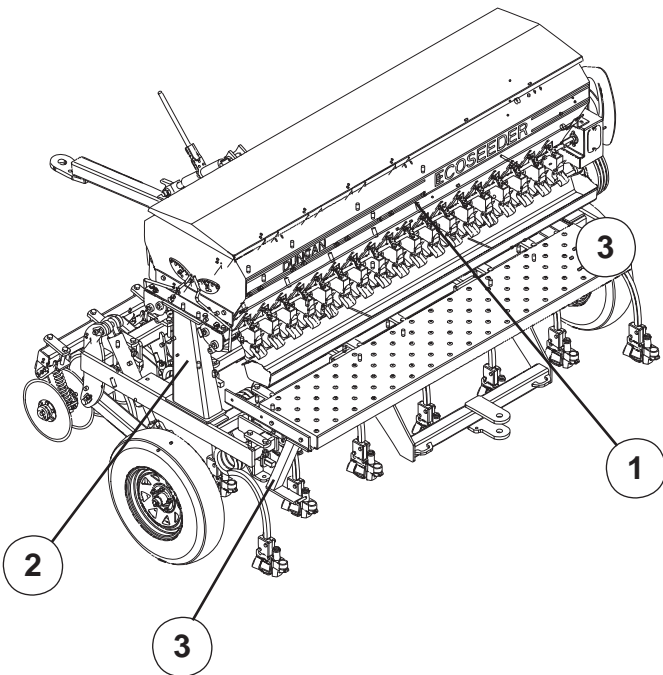

5 2



Pinch Points
Moving Parts

Inside Box Lid

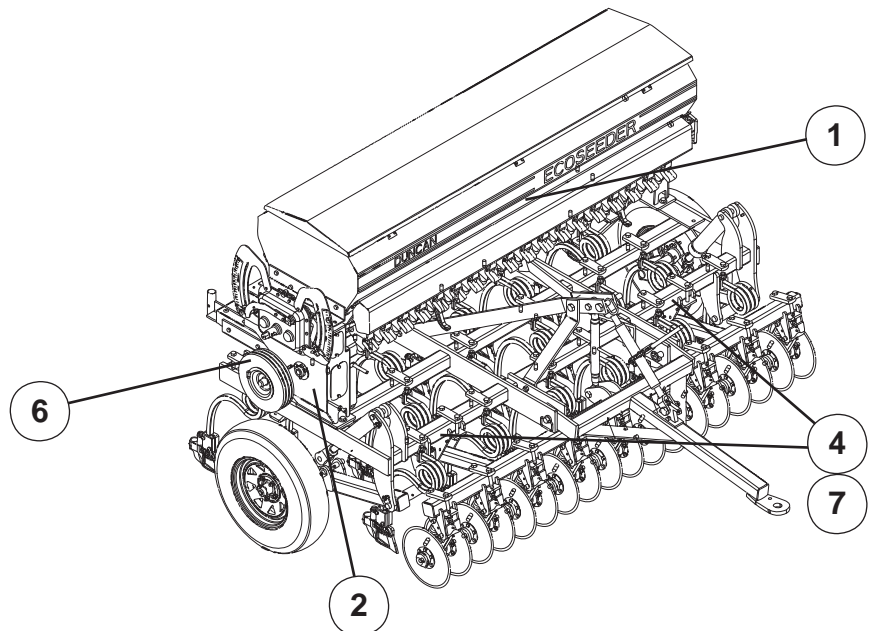

Item	Decal/Guard	Cross Ref.	Pt. No.	Qty
1	'No Ride'	Refer Page 11	43900	2
2	'Pinch Point/Moving Parts'	Refer Page 11	43901	3
3	'Slippery When Wet'	Refer Page 11	43902	2
4	'Keep Clear'	Refer Page 11	43909	2
5	Arrows (inside box lid)		43905	2
6	Jockey Drive Swing Guard	Refer Page 12	25746	1
7	'40 km/hr'		43912	2

Transport

- 1 Raise the drill into the transport position and hold at the full extent of the rams for a few seconds to allow cylinders to equalise.



- 2 **Important** - To avoid machine damage due to drill lowering during transport, always close the hydraulic valve at the quick release coupling. Move the handle to a position at 90° to the hydraulic line

- 3 **Maximum towing speed 40 km/hr.**

For countries other than New Zealand greater speed restrictions may apply, please refer to your local transport authority.



Ensure towing vehicle requirements are adequate for the towed vehicle e.g. mass, brakes. Refer to recommendations published by the local Land Transport Authority or equivalent.

Braking when towing can cause the load to jackknife. Use extra care when towing in adverse conditions such as mud, inclines and sharp bends.

Lower towing speeds are recommended on farm roads/tracks and where one wheel is on or over a road verge.

Operation

General Operation Guidelines

- 1 Use a sufficiently powerful tractor which is heavy enough to tow the drill safely.
- 2 Operate the drill at a speed of 6-12 km/hr (4-8 mph).
In stoney and uneven ground conditions a lower speed is more appropriate
- 3 Check that the drill is level during calibration and while seeding.
- 4 Check tyre pressure before seeding. Refer page 5.
- 5 Double check seed rates before seeding.
- 6 Raise the drill out of the ground when making any turns.
- 7 Raise the drill out of the ground before backing up.
- 8 Stretched sagging hoses disrupt seed flow. Slight tension may be restored by carefully shortening the affected hose; remove from the tube at ground level and cut accordingly.
Care must be taken not to shorten too much as the tension will pull the hose from the ground tube or damage the plastic metering funnel.
- 9 After prolonged storage, check to see that all drive mechanisms and hydraulic equipment are functioning correctly. Check that the seed/fertilizer tubes are not perished or blocked.

Sowing Speed

Typical travel speeds when sowing range from 6-12 km/hr in good conditions. In stoney and uneven ground conditions a lower speed is recommended to minimise rapid part deterioration. Sowing too fast can result in:

- 1 Poor contour following and uneven sowing depth.
- 2 Impact damage to:
 - a Ground engaging components.
 - b Bearings, housings & axles.
 - c Fasteners & structural components.
- 3 More extreme conditions will result in greater vibration and uneven seed flow at low seeding rates.

Sowing Depth Control

The sowing depth is dependent on:

- 1 The wheel height in relation to the chassis
- 2 Tyre pressure
- 3 Ground condition i.e. hard or soft

Stop collars (1) are fitted to both ram shafts. Ensure that both rams have the same size collars fitted as these control the sowing depth.

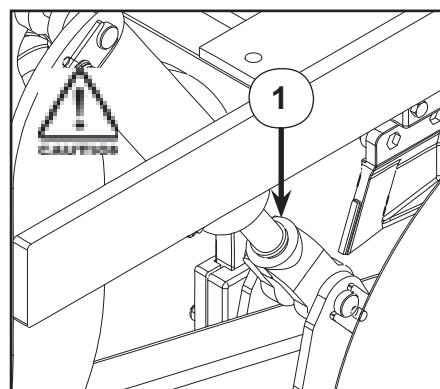

Level Drill

Use the drawbar turnbuckle to tilt the drill so it is sitting level. An adjustment may be required after a short period of use because the paint wears off the discs and the discs sharpen which in turn improves the penetration abilities. Ensure that the front and rear rows are at an even depth.

Transport Position

When in the transport position the hydraulic cylinders are fully extended.

Coulter Penetration Depth

To create the ideal seed bed the disc opener coulter should cut approximately 20mm below the inverted tee point. In hard and dry conditions this may not be achievable, and better machine/sowing performance may be achieved without using the disc openers. An indication of this will be the machine bouncing which will result in uneven sowing depth.

Coulters will give better penetration ability as they sharpen with use.

Eco Seeder Sowing Charts

Row Spacing 148.5 14R 16R 18R

FRONT BOX

PRODUCT	Shutter Slide*	Bottom Flap*	Type	Seed Rate (kg/ha)										Agitator Shaft
				Gearbox Setting Position										
				15	20	30	40	50	60	70	80	90	100	
Wheat	3/4	3	N					58	73	87	103	120	135	
Oats	Full	3	N					57	70	83	98	113	127	
Barley	Full	3	N					68	83	102	118	137	153	
Ryecorn	3/4	3	N					68	85	103	120	138	155	
White Peas	3/4	3	N			65	93	123	142	175	207	228	263	Disconnected
Green Peas	3/4	3	N			45	67	90	110	133	157	182	205	
Peren. Grass	Full	3	N	3.7	7.8	15	23	32	38	47				
Annual Grass	Full	3	N	4.7	9.3	18	27	35	43					
Pasture Mix*	Full	3	N		7.8	16	23	32	38	47				
Lucerne	3/4	1	F		0.0	5.3	7.8	10	13	15				Disconnected
Turnip	3/4	1	F	1.5	2.7	4.8	7.0	9.0						Disconnected
Kale	3/4	1	F		2.5	4.8	7.0	9.0						Disconnected
Swedes	3/4	1	F	1.3	2.5									Disconnected
Rape	3/4	1	F		2.5	4.5	6.7	8.3						Disconnected
White Clover	3/4	1	F	1.2	2.3	4.7	6.7	8.3						Disconnected
Red Clover	3/4	1	F		2.8	5.3	7.5	10.0	11.7	15.0				Disconnected
Super Phosphate	Full	3	N			53	80	107	135	165	198	228	263	
DAP Granules	Full	3	N					100	123	148	173	198	220	

REAR & SINGLE BOX

PRODUCT	Shutter Slide*	Bottom Flap*	Type	Seed Rate (kg/ha)										Agitator Shaft
				Gearbox Setting Position										
				15	20	30	40	50	60	70	80	90	100	
Wheat (41.2)	3/4	3	N					35	44	52	62	72	81	
Oats (37.2)	Full	3	N					34	42	50	59	68	76	
Barley (45.7)	Full	3	N					41	50	61	71	82	92	
Ryecorn (25.8)	3/4	3	N					41	51	62	72	83	93	
White Peas (302)	3/4	3	N			39	56	74	85	105	124	137	158	Disconnected
Green Peas (240)	3/4	3	N			27	40	54	66	80	94	109	123	
Peren. Grass (2.27)	Full	3	N	2.2	4.7	9	14	19	23	28				
Annual Grass (4.4)	Full	3	N	2.8	5.6	11	16	21	26					
Pasture Mix* (-)	Full	3	N		4.7	9.5	14	19	23	28				
Lucerne (3.17)	3/4	1	F			3.2	4.7	6.2	8	9				Disconnected
Turnip (2.17)	3/4	1	F	0.9	1.6	2.9	4.2	5.4						Disconnected
Kale (3.20)	3/4	1	F		1.5	2.9	4.2	5.4						Disconnected
Swedes (3.25)	3/4	1	F	0.8	1.5									Disconnected
Rape (3.50)	3/4	1	F		1.5	2.7	4	5						Disconnected
White Clover (1.11)	3/4	1	F	0.7	1.4	2.8	4	5						Disconnected
Red Clover (2.23)	3/4	1	F		1.7	3.2	4.5	6	7	9				Disconnected
Super Phosphate	Full	3	N			32	48	64	81	99	119	137	158	
DAP Granules	Full	3	N					60	74	89	104	119	132	

Note

Seed rates shown are approximate only for the respective gearbox setting. It is recommended that the calibration procedure is always used. Refer Page 18.

Shutter Slide*: For Grain, changing the Shutter Slide from 3/4 to Full gives 10% to 15% more flow.

Pasture Mix*: Test Mixture = 72% Perennial Grass, 8% White Clover, 8% Cocksfoot, 8% Concord, 4% Red Clover

Bottom Flap*: The values shown were the optimum test settings, decreasing the gap may cause seed damage, too large a gap will give intermittent flow rates. (Flaps are spring loaded to cope with small variations in seed/granule size).

Metering Wheel*: N = Normal Metering Wheel
F = Fine Seed Metering Wheel

TSW*: $\frac{\text{TSW(gm)} \times \text{Desired Plants/m}^2}{\text{Germination \%}} = \text{Sowing Rate (Kg/Ha)}$

Basic Calibration Procedure

Gearbox Setting Lever

To set the seed rate at the gearbox, slacken the tri knob (1) by turning counter-clockwise and push from below into the position indicated in the Sowing Chart. Retighten the star knob firmly. When one box is being calibrated, set the other one to zero to prevent loss of product.

Note that the front most lever (yellow letters on black background) controls the rear box.

Important

The settings shown in the Sowing Charts (kg/ha) can only serve as reference values. Deviations may occur caused by differences in the size, shape, density of the seed/fertilizer and by the dressing agent. **Therefore prior to any sowing, always carry out calibration trials to accurately determine the actual seed rate.**

Using the stepless variable speed gearbox, the speed of the metering shaft and thus the seed rate is set steplessly. The higher the figure indicated on the scale by the setting lever the greater the seed rate.

Setting Seeder Shutter Slides

The varying flow properties of seeds require different shutter

A	B	C
Closed	3/4 Open	Fully Open

slide positions which may be found in the Sowing Chart for the individual type of seed or fertilizer. This corresponds to one of the three settings as shown.

Bottom Flap Settings

The various seed sizes require matching bottom flap clearances below the metering wheel. The adjusting plate allows for 10 different settings. The required position for the seed type may be found in the Sowing Chart. The control levers are located on the LH end of the seedbox, (opposite end to the gearbox).

Number "1" corresponds to the minimum (closed) position and "10" the maximum gap.

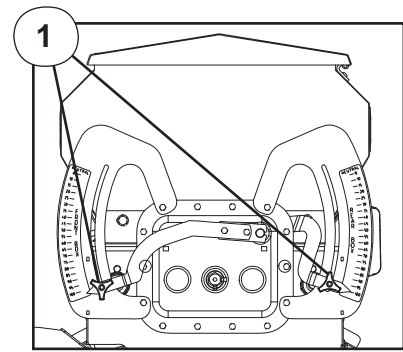

Dual Box unit shown

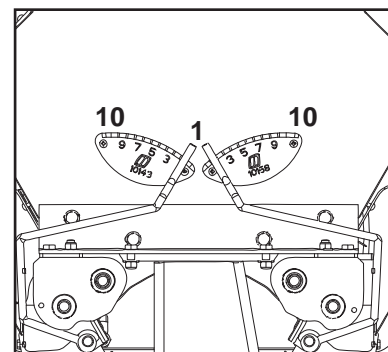
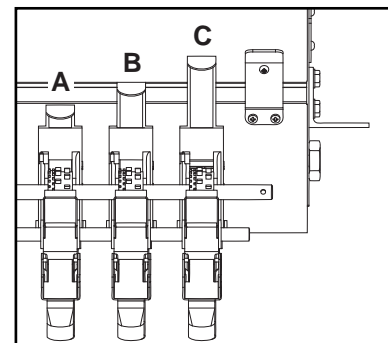

Dual Box unit shown

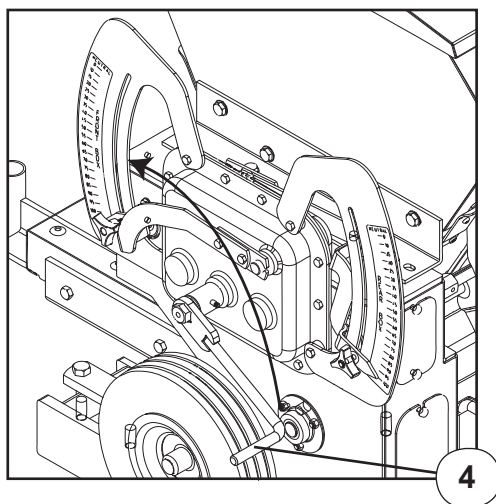
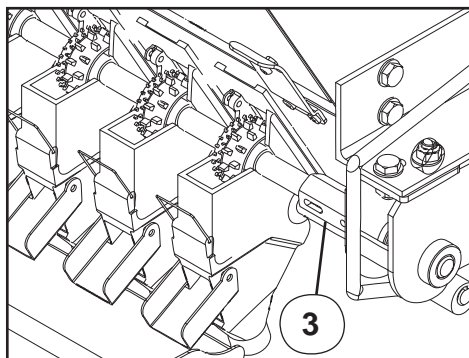
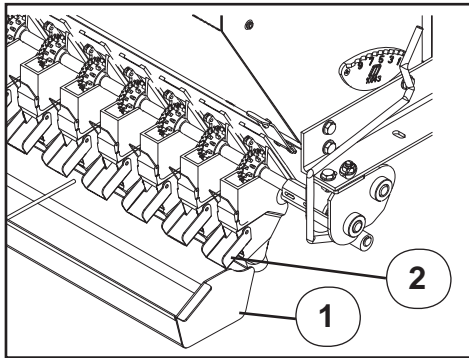

Basic Calibration Procedure (Continued)

Seed Calibration

The calibration test should be done to confirm the required seed rate and is done with the drill stationary and level.

Seed/Fertilizer Calibration Procedures

- 1 Remove the calibration tray from the storage brackets on the seedbox. Place the calibration tray (1) on the support members below the seeders .
 - 2 Position all the clear plastic seed diverters (2) to redirect the seed into the calibration tray.
 - 3 Make sure all the shutters are open and set to the position indicated in the seed charts for the particular seed (Page 17).
 - 4 Agitator Shaft - Check the Seed Chart "Hints" whether to connect or disconnect the shaft during seeding by removing the M10 bolt (3).
 - 5 For the test, half fill the box with seed. If this is not possible make sure the seed is evenly distributed within the box.
 - 6 For setting method refer to Basic Calibration Procedures (Page 18).
- Note** For seeds which are not covered in the Sowing Chart (Page 17), use the figures for a seed of comparable size and shape.
- 7 Place the crank handle (4) over the hexagonal drive dog on the gearbox input shaft and turn anti-clockwise until the seed flows consistently from the seeders. To ensure complete filling of the seed unit continue turning the crank until an even flow of seed is coming out of the seeder units, then empty back into the seedbox. The drill is now ready for calibration.
 - 8 Turn the crank handle anti-clockwise the required number of revolutions as detailed on the following page.

Note The Calibration is usually done for 1/40th hectare. For very small seed rates or when using inaccurate scales (i.e. unable to measure to the nearest gram) the calculation based on 1/10th hectare should be used.

Scales must be accurate to 2 grams as any error will be multiplied by either 10 or 40 giving inaccurate calibration results.

Basic Calibration Procedure (Continued)

Hand Crank Turns for Seed Rate Calibration

The tables represented below are for arable conditions (**worked ground**) and are calculated to indicate an average situation. If there is any doubt as to the accuracy of these figures for the conditions, it is advisable to run checks on the calibration figures listed. Refer Page 22, (**Wheel Slip Deviations**).

Machine Size	Row Spacing(mm)	Sowing Width (m)	Turns for 1/40 Hectare	Turns for 1/10 Hectare
14 Run	148.5	2.079	29	114
16 Run	148.5	2.376	25	100
18 Run	148.5	2.673	22	89

- 9 Weigh the seed collected during the test in kilograms.

Caution: Scales must be accurate to 2 grams, as any error will be multiplied by either 10 or 40, giving inaccurate calibration results.

- 10 Calculate the seed rate by multiplying the kgs previously collected x 40 (1/40th ha method) or x 10 (1/10th ha method) depending on the requirement. If the resultant calculation does not produce the desired seed rate use the enclosed seed rate calculator disc to determine the correct gearbox setting.

Refer **Use of Seed Rate Calculator** Page 21.

Suggestion: To be on the safe side and until confidence has been gained with the method of calibration it is advisable to conduct a second test at the newly determined gearbox setting.

- 11 Where a coated seed is used it is advisable to check the calibration after 1 hectare as dressings can tend to create a coating on the seed metering wheels thus changing the the flowing properties of the seed which in turn alters the seed rate.

For $\frac{1}{40}$ Hectare (250m²) Calibration
Seed Rate = Actual Seed Collected (kg) x 40

For $\frac{1}{10}$ Hectare (1000m²) Calibration
Seed Rate = Actual Seed Collected (kg) x 10

Basic Calibration Procedure (Continued)

Use of Seed Rate Calculator

Determining the gear box scale setting using the calculator.

Usually the first calibration test yields a different seed rate. However with the value determined from the first test it is possible to determine the correct gearbox setting with the aid of the enclosed disc calculator. The disc calculator consists of 3 scales. An outer white scale (1) for all seed rates above 30 kg/ha and an inner scale (2) for all seed rates below 30 kg/ha. On the middle coloured scale (3) are all the gearbox setting numbers to a maximum value of 100.

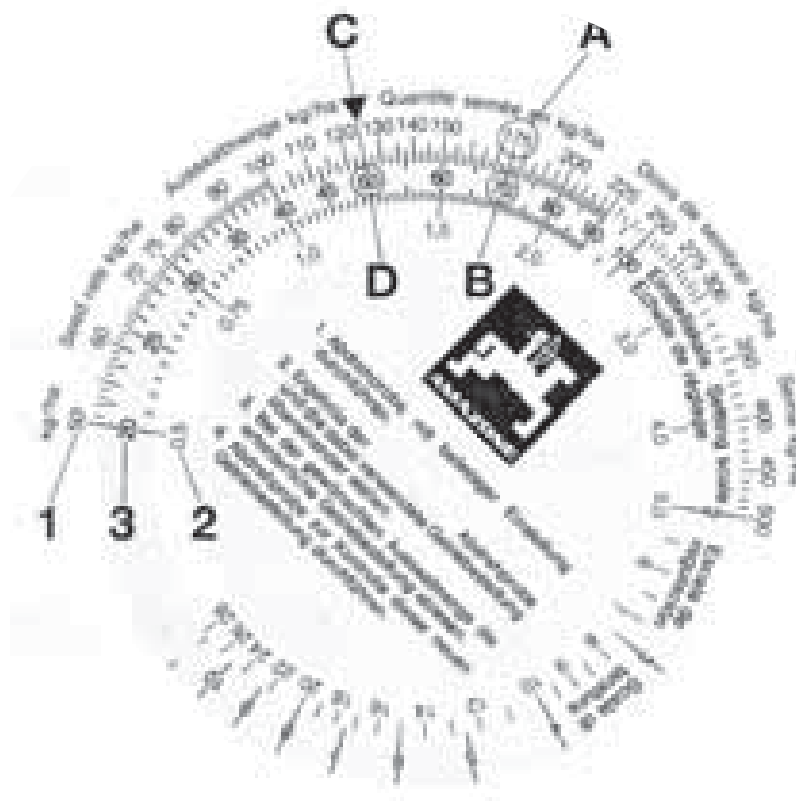

Setting Example (Desired Seed Rate 125kg/ha)

- 1 From the calibration procedure at a gearbox lever setting of "70", a seed rate of 175 kg/ha is obtained.
- 2 Turn the inner disc until the measured seed rate of 175kg/ha (A) is in line with the related actual gearbox setting of "70"(B).
- 3 Read off from the disc rule the necessary gearbox setting for the required seed rate of 125kg/ha (C). In this example the correct setting is "50" (D).
- 4 To be on the safe side the new gearbox setting can be checked by another calibration test.

Basic Calibration Procedure (Continued)

Calibration Deviations

Deviations Between the Calibration Test and the Actual Seed Rate

The most frequent cause for changes between the calibration test and the seed rate lies in the flowing properties of seed during sowing. These changes in properties generally result from reactions of the dressing agents to temperature, humidity or abrasion. These changes will become even more obvious when the bottom flaps are incorrectly set. If the setting of these flaps leaves too large a gap an uncontrollable additional flow of seed can occur during seeding; especially when assisted by the drill bouncing, a condition not simulated while conducting the calibration tests. For this reason the basic setting of the bottom flaps should be checked at regular intervals.

Residues from the seed dressing on the bottom flaps and metering wheels can also influence the flowing properties of the seed and thus the seed rate. In such cases a balance will occur only after a period of time and it is recommended to repeat the calibration test to confirm the seed rate after 2-3 seedbox fillings, nominally when the seed box is half empty. Only then will a balance occur and the seed rate will stabilise.

Wheel Slip Deviations

It is always possible with rubber tyred drills in extreme ground conditions to get wheel slip. Not normally a problem with cleated type tyres in good condition, but more so in the arable situation with the less aggressive tread patterns. The result: large differences between the calibration test and the actual sowing rate, obviously less seed deposited than required. The number of crank turns indicated on page 20 is correct in most circumstances other than those mentioned above.

To check number of crank turns for calibration

Should you require to check this in a practical way proceed as follows:

For an area of 250m² (1/40 Hectare), the travel distance for your machine is shown below. Place the crank handle over the hexagonal drive dog on the gearbox. Move the machine forward over the measured distance, counting the number of turns of the crank handle as you go. Using this number of crank turns repeat the calibration.

Machine Size	Travel Distance (m)	Turns for 1/40 Hectare	Sowing Width (m)
14 Run	120.3	29	2.079
16 Run	105.2	25	2.376
18 Run	93.5	22	2.673

Basic Calibration Procedure (continued)

Sowing of Fine Seeds

For sowing small seeds the EcoSeeder Drill is equipped as standard with a combined normal and small seed metering wheel (1). During grain sowing and other larger varieties of seed both the large and small seed metering wheels are coupled and both rotate. In order to convert the seed drill to sow fine seed insert the crank handle and rotate clockwise until the holes (2) of the small seed wheel are visible.

Using the tool supplied (3) disengage the the pin inside the hole so that the large metering wheel rotates freely on the metering shaft.

When seed is to be sown again using the normal metering wheel press the pin, using the tool, from the large metering wheel side (opposite direction to before), back into the hole of the small seed wheel thus reconnecting the drive between the two.

This must be done for the whole bank of wheels.

Caution - When resetting the metering wheels on the seeder shaft

Care should be taken when tightening the grub screws on the small seed wheel. Adjust the grub screw until the movement of the metering wheel just stops, then tighten no more than 1/8 of a turn.

Do not overtighten as this can result in breakages while operating and may void the warranty on these units.

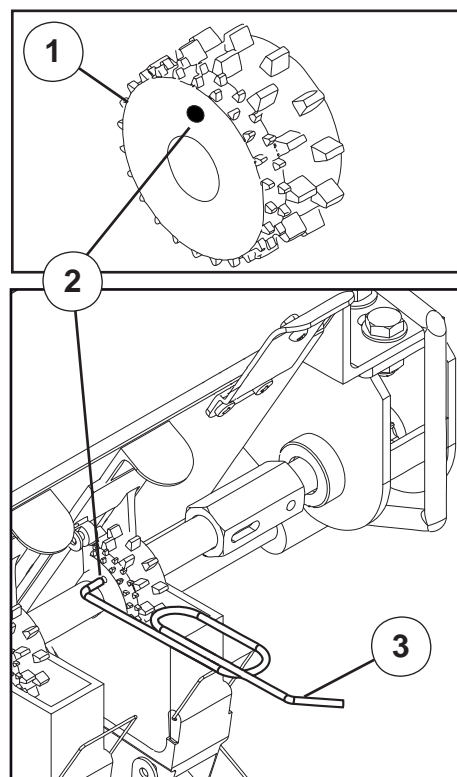

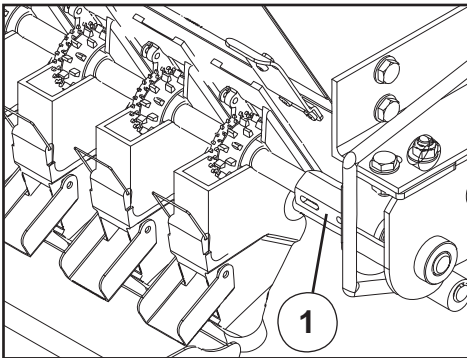

Small Seeds Calibration with Disconnected Agitator Shaft

The small seed metering wheel used in Duncan Drills is especially well suited for sowing small seeds such as rape, turnips and clover.

Due to the intensive action caused by the agitator the seeds can adhere to each other, or be damaged, causing irregular sowing/germination. **Therefore it is recommended that when sowing small seeds, especially oil seeds and thin shelled seeds, the drive to the agitator is disconnected.** To do this remove the linch pin or bolt. (1).

Deviations between the calibrated and actual seed rate can occur when residual dressing agent sticks to the bottom flaps and thus slows the flow of seed. Before beginning the actual calibration test fill the calibration trays by turning the crank handle at a high speed around the 90 setting on the gearbox scale. This will cause an immediate buildup of the dressing agent on the flaps. Return the contents of the calibration trays to the seed box and proceed with the actual calibration. Due to the residue buildup on the flaps your calibration will now reflect accurately the required seed rate.

Note - Remember to reconnect the agitator shaft as required for other seeds otherwise the consistency of seed rate will be affected.

Sowing Peas

Peas having the size and shape as illustrated in A (e.g. White Field Peas), can be sown in all Duncan Drills with this type of metering wheel.

The flap should be set to a gap of at least "3" on the flap setting lever (Page 18).

With these peas it should not be necessary to run the agitator shaft.

Peas having the size and shape as illustrated in B (e.g. Green or Garden Peas), tend to bridge inside the seedbox and do not flow freely.

This multi-faceted pea requires agitation for sowing.

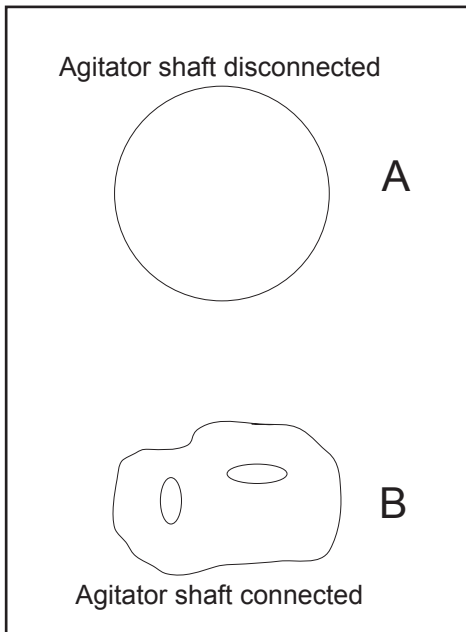

Farmscan Jackal v3 Settings Setup

Refer to the manual supplied with your Farmscan Jackal kit for information and operation.

Farmscan Jackal v3 Factory Setup for EcoSeeder

Refer to pages 6,9,11 of the Farmscan Jackal v3 manual.

Input 2 -Two wire 'reed' sensor for 'Area/Speed Wheel' measurement taken from shaft on drive pedestal.

The white 'signal' lead is connected to input A2.

Input 2 Edit	
m/pulse	
Auto Set:	
Target:0.000m	
Meas.pulses:	0
Manual Ratio:	2.750000
NEXT	EDIT

Other Settings	
Implement Width:	x.xxx m
Extern.Run/Hold:	Disabled
Alarm Beep:2	
NEXT	EDIT

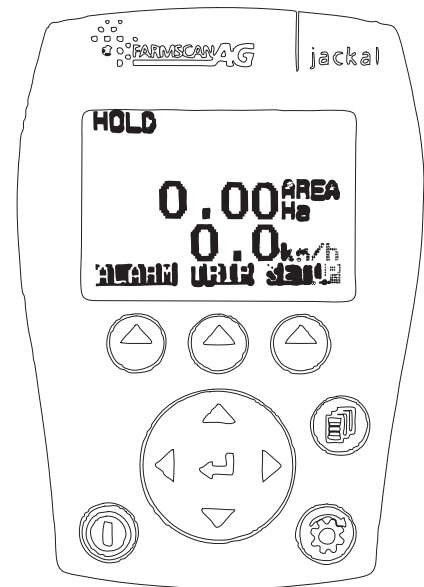

Machine Size	Row Spacing (mm)	Sowing Width (m)
14 Run	148.5	2.08
16 Run	148.5	2.38
18 Run	148.5	2.67

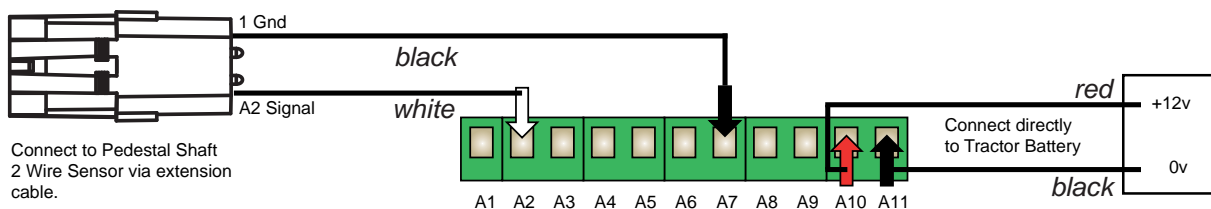

Refer to the Farmscan manual if you want to make additional sensor connections.

It is advisable, as with all things electronic, to have a backup of your totals. We suggest you record these on a daily basis in a notebook or diary.

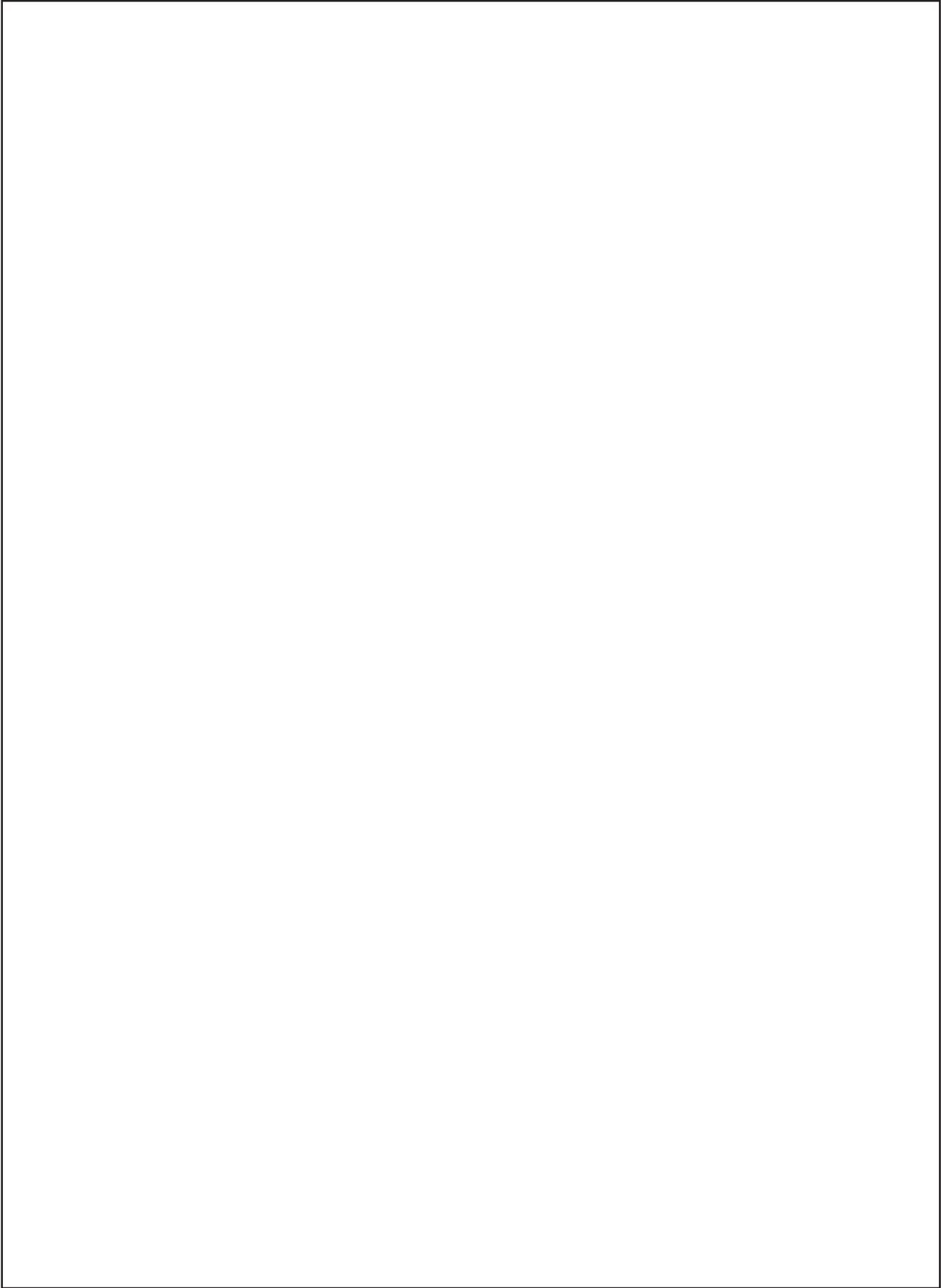

Maintenance & Care

General Safety and Accident Prevention Advice



- 1 Make sure that if the tractor remains attached to the drill that the ignition key is removed.
- 2 During maintenance the drill should be supported in such a manner that if hydraulic failure was to occur the machine would still be adequately supported.
- 3 Wear gloves when handling components with cutting edges such as worn discs etc...
- 4 Disconnect the electrical supply from the tractor before doing any electrical maintenance.
- 5 Refer to safety sections for more safety information.

General Cautionary Maintenance Advice



- 1 **Electric Welding** - With the electronic equipment in modern tractors it is advisable to completely disconnect the implement from the tractor, or at the very least disconnect the alternator before attempting any welding.
- 2 **Hydraulics** - Ensure hydraulic couplings (male & female) are clean before connecting. Dirty couplings will result in hydraulic oil contamination and hydraulic cylinder seal damage and bore scores. This in turn will result in oil leakage past the piston seals.

No filter is fitted to the hydraulic system. If hydraulic fittings and oil supply are not going to be kept clean it is recommended that a filter be fitted to prevent hydraulic cylinder damage.
- 3 **Water Blasting** - Water blasting, steam cleaning or other pressurised cleaning processes can force dirt etc. into undesirable places that may cause damage or rapid part wear to items such as bearings, seals, chains, bushes etc. Caution must be exercised.

Maintenance & Care - Lubrication Instructions

Precautions with Grease

Greases should not be mixed as the structure may be weakened by the mixes of different types of thickener, which may cause softening and loss of grease from the bearings by running out.



Your new Duncan EcoSeeder will give long and efficient service if given normal care and maintained properly.

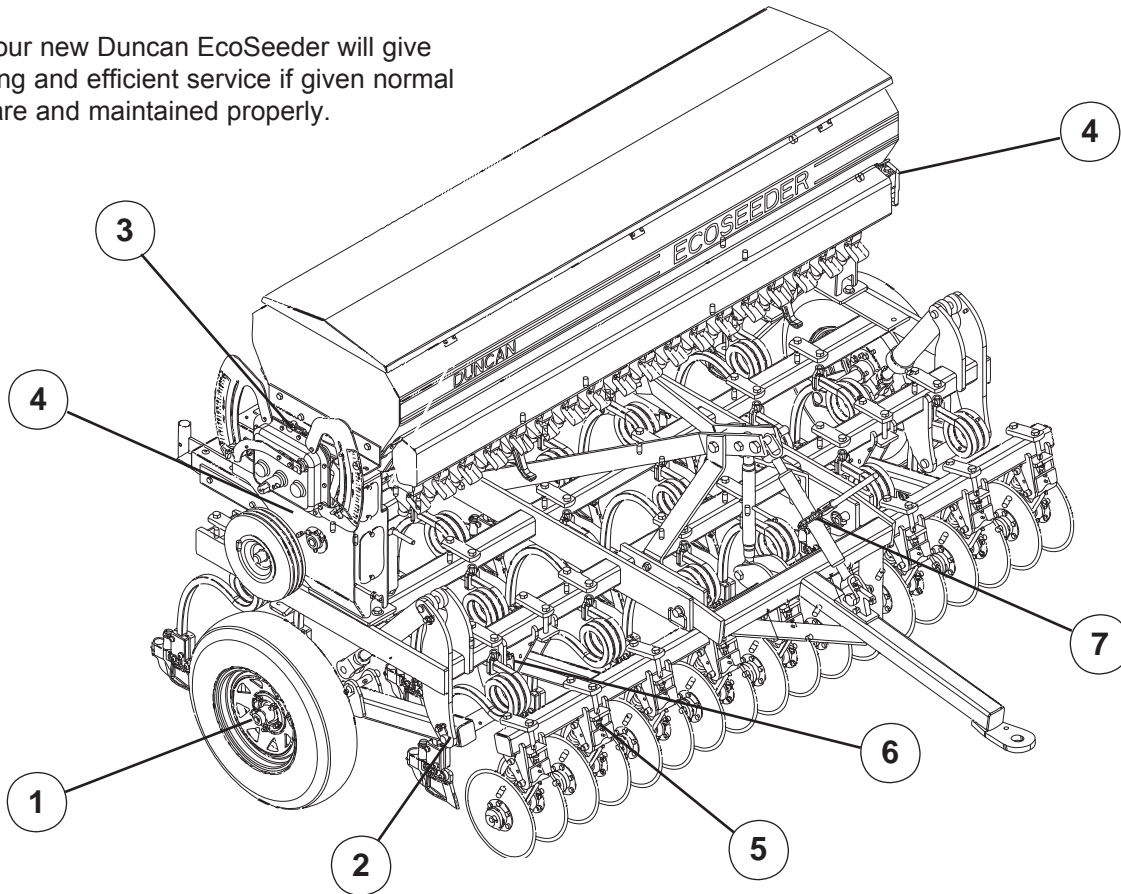

Lubrication Chart

Item	Components	Lubricant	Frequency*
1	Wheel Bearings	Castrol LMX Grease	Annually
2	Wheel Leg Pivots	Castrol LMX Grease	Weekly
3	Gearbox	Castrol Oil Agri Trans Plus	Maintain Level
4	Drive Chains	Suitable Roller Chain Lubricant	See Maintenance Schedule
5	Disc Arm Castings	Castrol LMX Grease	Daily
6	Disc Opener Fr. Pivots	Castrol LMX Grease	Monthly
7	Turnbuckles	Castrol LMX Grease	Monthly

* The lubrication frequencies are only a guide. Actual frequency will be dependent on extent of use and ground conditions.

Maintenance & Care - continued

Components	Daily (or after 20Ha)	Weekly (or after 75Ha)	Pre Season (or 500 Ha)
Disc Openers	•	•	•
Seeders/Agitators/Bottom Flaps	•	•	•
Pivot Pin Fasteners		•	•
Roller Chains		•	•
Gearbox		•	•
Hydraulics (Oil Leaks)		•	•
Tyre Pressures		•	•
Bolted Connections			•

Maintenance Schedule

(Refer also to Summary Chart, above)

1. Bolted Connections

All bolted connections of the machine should be checked after the first 3 to 5 hours of operation and retightened if necessary and thereafter at regular intervals. It is suggested that this is done every 500 hectares or annually, whichever occurs first.

2. Gearbox

The oil level in the gearbox can be seen in the oil gauge window. Changing the gearbox oil is recommended once a year or sooner if the oil is discoloured. For draining, remove the drain plug at the bottom of the gearbox and the fill plug at the top. Replace drain plug before refilling. Castrol Oil Agri Trans Plus or equivalent* should be used.

The total filling capacity is 1.25 litres.

DO NOT OVERFILL.

**Oil Specification to meet the requirements of : SAE 10W-30, API GL-4, Massey Ferguson M1143, John Deere J20C, J20D, Case MS 1207, Ford/New Holland M2C-134D, M2C-86 A/B/C*

3. Hydraulics

Ensure hydraulic couplings (male & female) are clean before connecting. Dirty couplings will result in hydraulic oil contamination and hydraulic seal and bore damage which will cause oil leakage past the seals.

No filter is fitted to the hydraulic system. If the hydraulic fittings and the oil supply are not going to be kept clean then it is recommended that a filter be fitted to prevent hydraulic cylinder damage.

4. Drive Chains

All drive chains (1) should be checked after every 20 hours of operation and weekly thereafter or after 75Ha of operation.

The metering wheels of the seed drill are driven via roller chains from the drive wheel.

Cleaning of the roller chains is recommended annually or pre-season and after long periods of operation.

Remove the chain, wash in kerosene and then dip in heated grease or oil or spray with a suitable commercial roller chain lubricant.

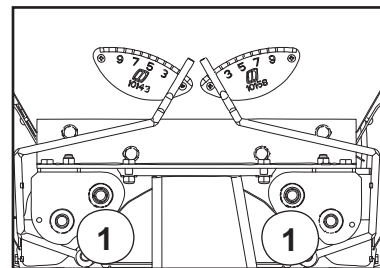

5. Wheel Arm Pivots

Wheel arm pivots must be greased regularly (weekly or after every 75Ha) to provide lubrication and flush out any dirt.

6. Tyre Pressure

The recommended tyre pressures may be found on page 5. Check the tyre pressure regularly to ensure correct pressure is maintained. Weekly checks are recommended.

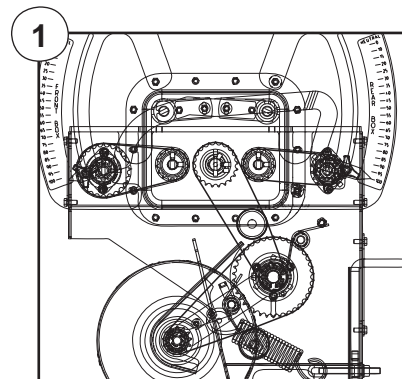

7. Disc Openers

Front coulter bearings are sealed and do not require lubrication. Check discs for any lateral movement (wobble) on a regular basis. Replace bearings if there is any noticeable wobble.

There is one grease nipple on each disc opener frame pivot and disc assembly casting. Frame pivots should be greased monthly while disc castings should be greased daily to provide lubrication and to flush out any dirt.

8. Length of Seed/Fertiliser Tubes

These tubes can stretch over a period of time and require checking at approximately six monthly intervals. Shorten if necessary to avoid bends which will restrict the flow of seed/fertiliser.

9. Framework

The framework structure should be inspected annually for defects, i.e., cracks in members or welded connections. The framework should be cleaned prior to the inspection.

Maintenance & Care (Continued)

9. Bottom Flaps

The required seed rate is controlled by both the metering wheels and the bottom flaps. The seed flows from the seed box into the metering wheel housings. Inside the metering wheel housing (1) the seed is caught between the metering wheel (2) and the bottom flap (3). The metered amount of seed is transported by the metering wheel to the edge of the bottom flap where it drops off into the seed guide tube which leads to the coulter. Varying grain sizes require the matching of the flap clearance to the different grain sizes. This matching is done by raising or lowering the bottom flaps by using the flap adjusting lever on the LH end of the seed box. If larger foreign particles, e.g. stones get between the metering wheel and the bottom flap, the bottom flap can give way downwards. A strong return spring (4) brings the bottom flap immediately back into the working position.

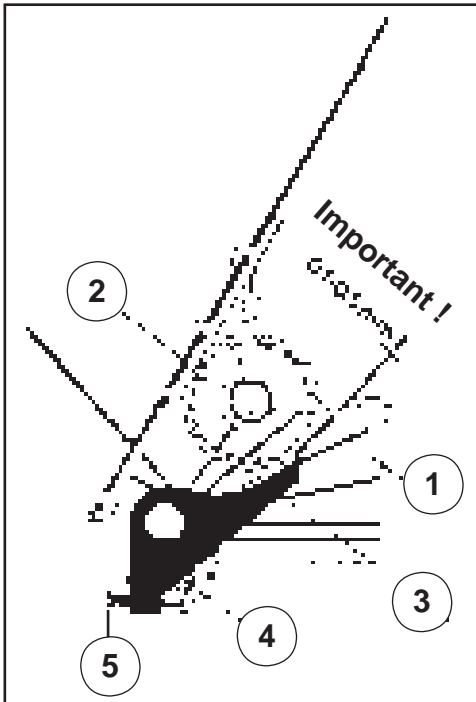

The metering system should be checked every 1/2 year or before any sowing period with an empty seed box and empty metering housings.

Use the following procedure:

Put the bottom flap setting levers (6) (located on the LH end of the seed boxes) in position "1" for the front box and position "1" for the rear box.

By turning the metering wheel shaft by hand check the flaps are all set to a gap of 0.1 to 0.5mm.

To adjust individual flaps use the spring tensioning screw (5).

Note: Maintenance Schedule (page 30)

Where the frequency is given in terms of use (eg. weekly) or area covered (eg. 75 Ha) perform the maintenance task based on whichever occurs first.

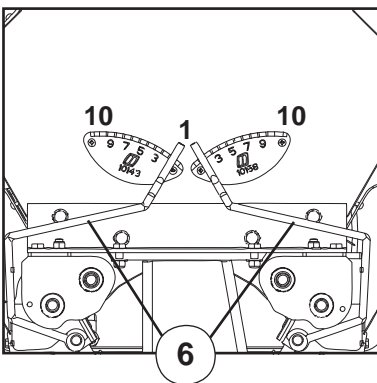

Preparing the Machine for Storage.

Locate on a dry level surface. The machine should be stored wherever possible so the rams are not supporting any weight. The drive chains should be lubricated with suitable roller chain lubricant before prolonged periods of storage.

For longer term storage remove seed/fertiliser tubes from the boot assembly and allow to hang without deformation. Check tube lengths when replacing.

It is recommended that maintenance be carried out at the end of the season, giving sufficient time to obtain spare parts and/or carry out repairs if required.

EcoSeeder Troubleshooting

Problem	Possible Cause	Action
Over Sowing	Jockey wheel under inflated	<i>Check pressure</i>
	Are the hectare meter settings correct?	<i>Check settings</i>
	Has the calibration procedure been followed correctly?	<i>Re-calibrate</i>
	Is the shutter slide open too wide?	<i>Check settings</i>
	Is the flap setting open too wide?	<i>Check settings</i>
	Too larger gap between seeder unit & bottom flap (should be 0.1 to 0.5mm when on setting 1)	<i>Check settings/ Check gap</i>
	Quadrant Tri-knob coming loose	<i>Check and tighten</i>
Under Sowing	Has the calibration procedure been followed correctly?	<i>Re-calibrate</i>
	Are the calibration scales in Kg (not lbs)?	<i>Check scales</i>
	Sowing at shallow depths. Is there sufficient pressure on the jockey wheel?	<i>Check and adjust spring pressure</i>
Drill not sowing until quadrant levers are well down on the scale	The two bolts on the quadrant lever have come loose	<i>Check and tighten</i>
Each box is sowing at different rate even when both set on the same setting	Transfers may not be aligned with each other	<i>Check and recalibrate</i>
Tines are moving	Too much turning with drill in the ground	<i>Keep turning to minimum Lift out on turns</i>
Drill not penetrating into ground/drill riding out of ground	Disc openers are keeping the drill from penetrating into the ground	<i>Lift discs out of the ground</i>

Calibration Chart and Handy Hints

Eco Seeder Sowing Charts

Row Spacing 148.5 14R 16R 18R

FRONT BOX

PRODUCT	Shutter Slide*	Bottom Flap*	Type	Seed Rate (kg/ha)										Agitator Shaft
				Gearbox Setting Position										
				15	20	30	40	50	60	70	80	90	100	
Wheat	3/4	3	N					58	73	87	103	120	135	
Oats	Full	3	N					57	70	83	98	113	127	
Barley	Full	3	N					68	83	102	118	137	153	
Ryecorn	3/4	3	N					68	85	103	120	138	155	
White Peas	3/4	3	N			65	93	123	142	175	207	228	263	Disconnected
Green Peas	3/4	3	N			45	67	90	110	133	157	182	205	
Peren. Grass	Full	3	N	3.7	7.8	15	23	32	38	47				
Annual Grass	Full	3	N	4.7	9.3	18	27	35	43					
Pasture Mix*	Full	3	N		7.8	16	23	32	38	47				
Lucerne	3/4	1	F		0.0	5.3	7.8	10	13	15				Disconnected
Turnip	3/4	1	F	1.5	2.7	4.8	7.0	9.0						Disconnected
Kale	3/4	1	F		2.5	4.8	7.0	9.0						Disconnected
Swedes	3/4	1	F	1.3	2.5									Disconnected
Rape	3/4	1	F		2.5	4.5	6.7	8.3						Disconnected
White Clover	3/4	1	F	1.2	2.3	4.7	6.7	8.3						Disconnected
Red Clover	3/4	1	F		2.8	5.3	7.5	10.0	11.7	15.0				Disconnected
Super Phosphate	Full	3	N			53	80	107	135	165	198	228	263	
DAP Granules	Full	3	N					100	123	148	173	198	220	

REAR BOX & SINGLE BOX

PRODUCT	Shutter Slide*	Bottom Flap*	Type	Seed Rate (kg/ha)										Agitator Shaft
				Gearbox Setting Position										
				15	20	30	40	50	60	70	80	90	100	
Wheat (41.2)	3/4	3	N					35	44	52	62	72	81	
Oats (37.2)	Full	3	N					34	42	50	59	68	76	
Barley (45.7)	Full	3	N					41	50	61	71	82	92	
Ryecorn (25.8)	3/4	3	N					41	51	62	72	83	93	
White Peas (302)	3/4	3	N			39	56	74	85	105	124	137	158	Disconnected
Green Peas (240)	3/4	3	N			27	40	54	66	80	94	109	123	
Peren. Grass (2.27)	Full	3	N	2.2	4.7	9	14	19	23	28				
Annual Grass (4.4)	Full	3	N	2.8	5.6	11	16	21	26					
Pasture Mix* (-)	Full	3	N		4.7	9.5	14	19	23	28				
Lucerne (3.17)	3/4	1	F			3.2	4.7	6.2	8	9				Disconnected
Turnip (2.17)	3/4	1	F	0.9	1.6	2.9	4.2	5.4						Disconnected
Kale (3.20)	3/4	1	F		1.5	2.9	4.2	5.4						Disconnected
Swedes (3.25)	3/4	1	F	0.8	1.5									Disconnected
Rape (3.50)	3/4	1	F		1.5	2.7	4	5						Disconnected
White Clover (1.11)	3/4	1	F	0.7	1.4	2.8	4	5						Disconnected
Red Clover (2.23)	3/4	1	F		1.7	3.2	4.5	6	7	9				Disconnected
Super Phosphate	Full	3	N			32	48	64	81	99	119	137	158	
DAP Granules	Full	3	N					60	74	89	104	119	132	

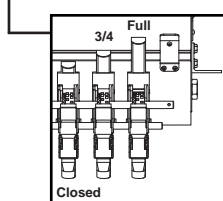

Hectaremeter Settings

Machine Size	Row Spacing(mm)	H1	H2
14 Run	148.5	2597	2.08
16 Run	148.5		2.38
18 Run	148.5		2.67



Calibration Chart and Handy Hints

Basic Calibration Procedure

Seed Calibration

The calibration test should be done to confirm the required seed rate and is done with the drill stationary and level.

Seed Calibration Procedures

- 1 Place the calibration tray in the brackets
- 2 Position all the clear plastic seed diverters to redirect the seed into the calibration tray
- 3 Set Shutter Slide
- 4 Set Bottom Flap
- 5 Disconnect/connect Agitator Shaft
- 6 Select gearbox setting
- 7 Place the crank handle over the hex drive and turn anti-clockwise until the seed flows consistently from all seeder units then empty into the seedbox.
- 8 Turn the crank handle anti-clockwise the required number of revolutions.

Machine Size	Row Spacing(mm)	Sowing Width (m)	Turns for 1/40 Hectare	Turns for 1/10 Hectare
14 Run	148.5	2.079	29	114
16 Run	148.5	2.376	25	100
18 Run	148.5	2.673	22	89

- 9 Weigh seed (scales must be accurate to within 2 grams)

10

For $\frac{1}{40}$ Hectare
Seed Rate = Actual Seed Collected (kg) x 40

For $\frac{1}{10}$ Hectare
Seed Rate = Actual Seed Collected (kg) x 10

HANDY HINTS

Keep a constant pace during calibration turns

Bottom Flap: check gap setting (0.3mm) regularly to avoid inconsistent seeding and or seed damage. REFER TO MANUAL

For products not on sowing chart choose a similar product

For accurate seeding, ensure jockey wheel is inflated to maximum pressure shown on the tyrewall

Keep turning in ground to a minimum

When fitted, disc opener should run approx 20mm deeper than boot

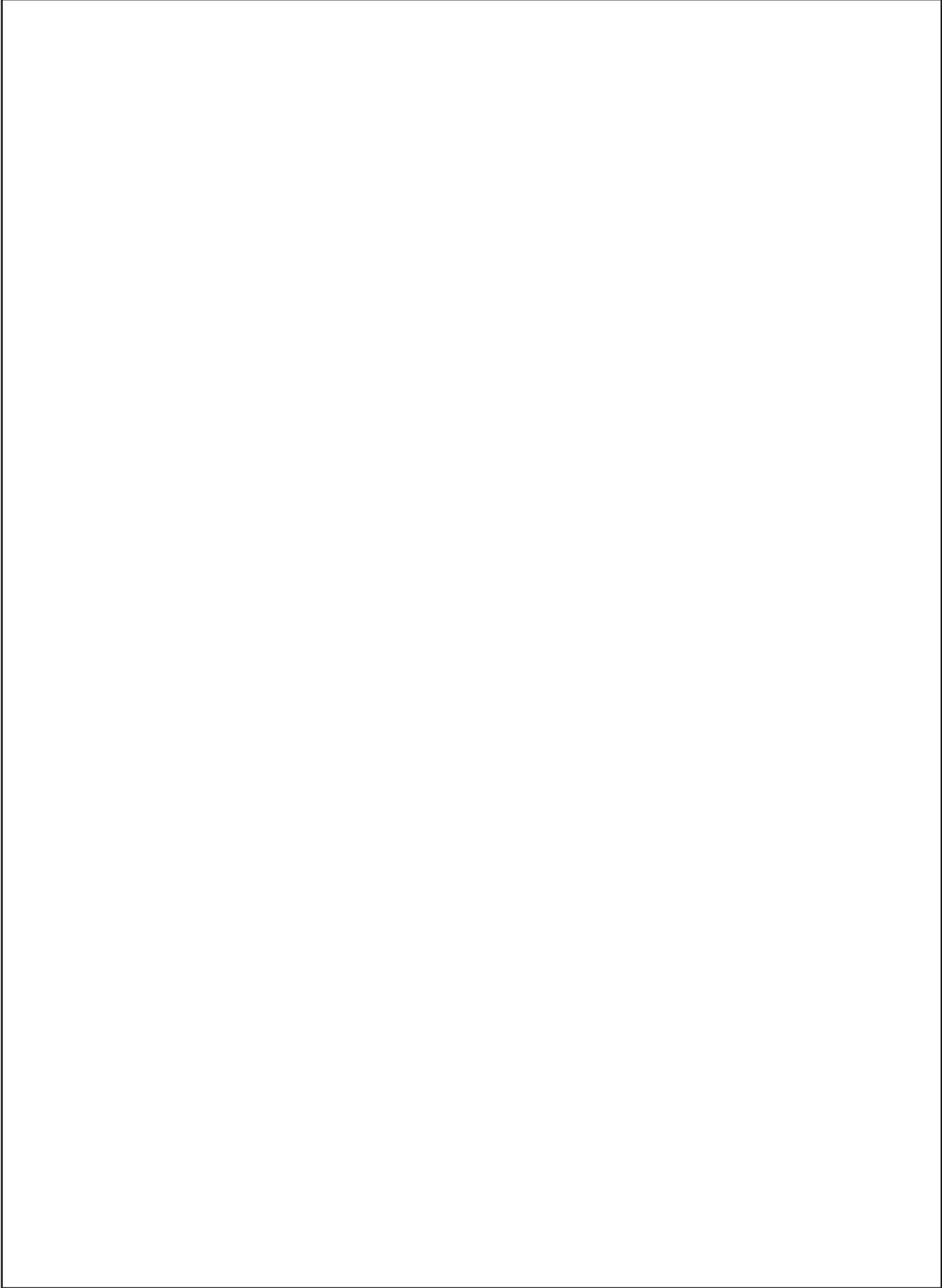

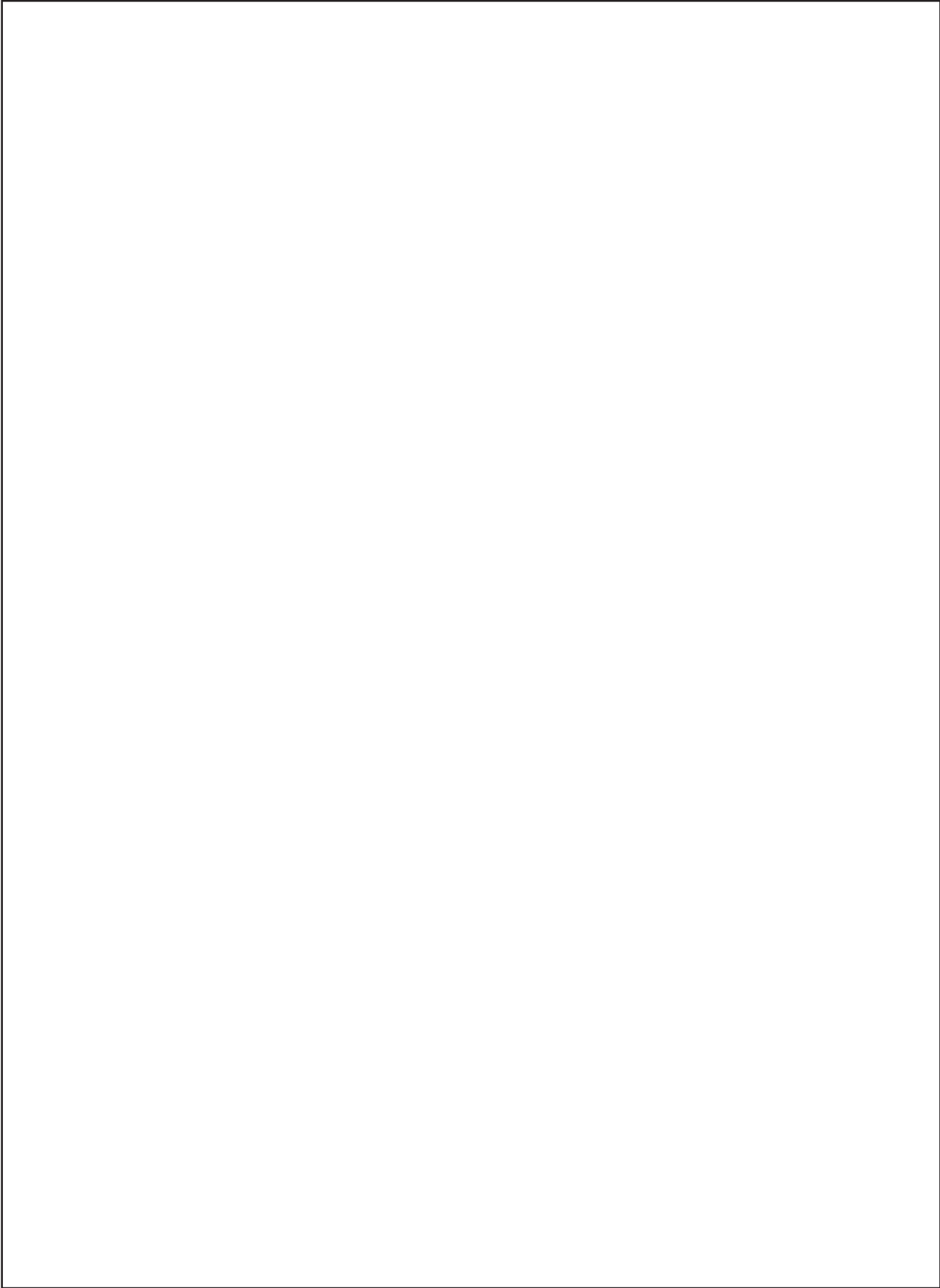

Parts List



'EcoSeeder' Seed Drill

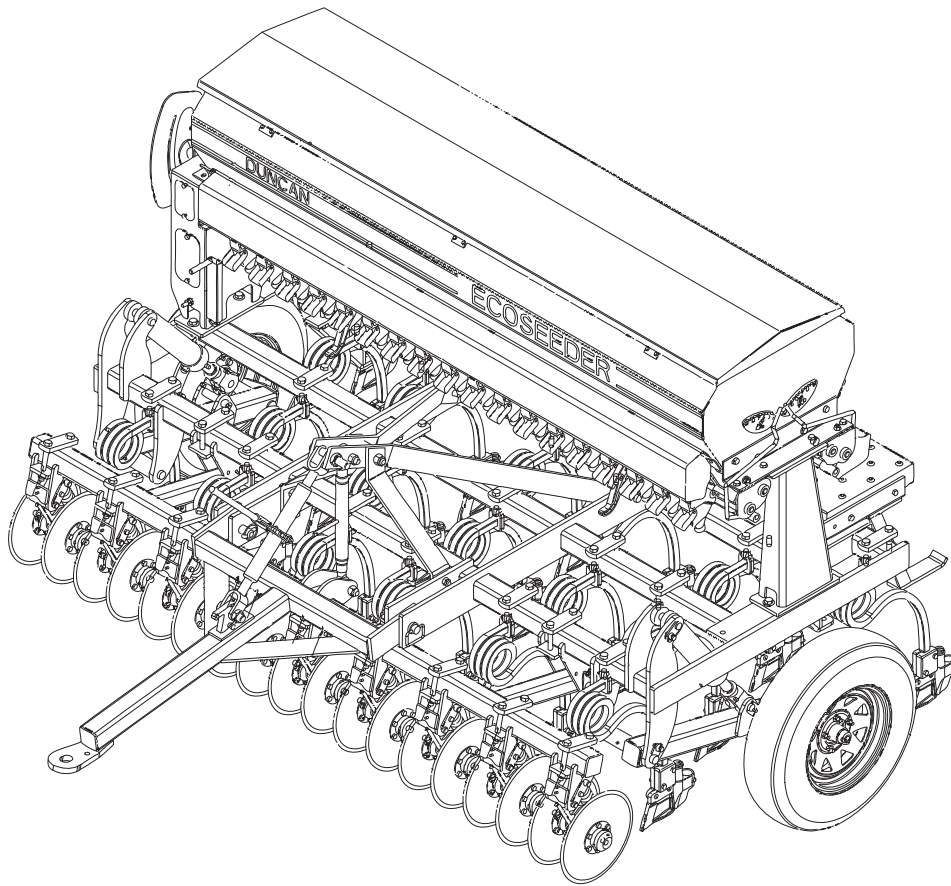

Built to work.

Head Office:
P.O. Box 2018
Hilton Highway, Washdyke
Timaru, New Zealand
Telephone (03) 688 2029
Facsimile (03) 688 2821

Australian Branch:
4B Silverton Close
Laverton North 3026
Melbourne, Australia
Telephone (03) 9314-9666
Facsimile (03) 9314-6810

Pt. No. 67392
Issue 0918

'EcoSeeder' Seed Drill Dual Box Complete Assy

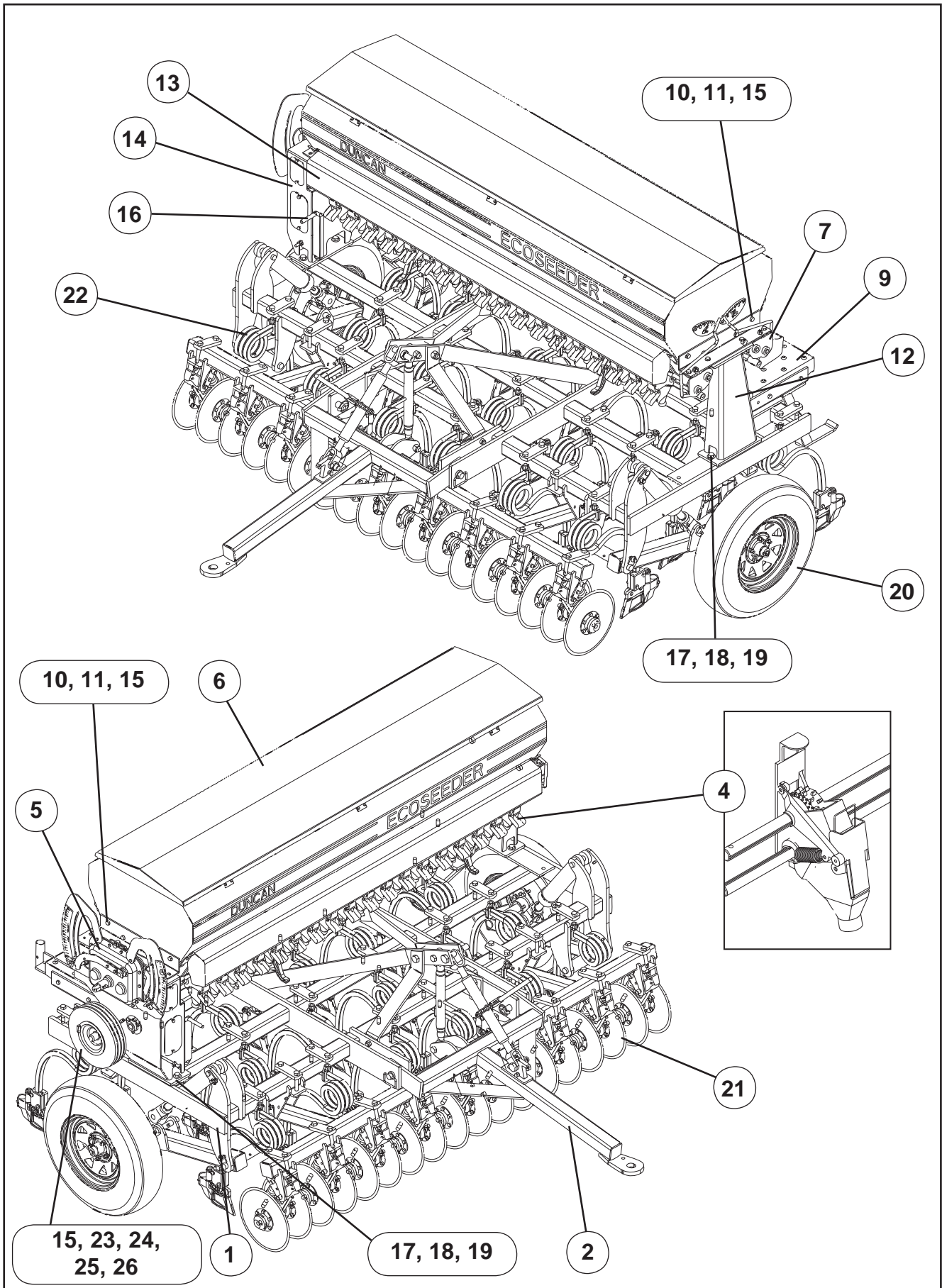

‘EcoSeeder’ Seed Drill Dual Box Complete Assy

ITEM	PART No.	DESCRIPTION	QTY
1	Refer pages 44	Main Frame Assembly	1
2	Refer pages 44	Drawbar Assembly (Optional)	1
3	Refer pages 69	Hectaremeter Kit (Optional -not shown)	1
4	Refer pages 59	Seeder Mechanism	32 36
5	Refer pages 54	Gearbox Final Assembly	1
6	Refer pages 62	Seedbox Assembly	1
7	Refer pages 66	Agitator Drives	2
8	Refer pages 67	Agitator Shaft Assembly (Inside Seedbox)	2
9	Refer pages 68	Footboard Arrangement	1
10	45019S	M12 x 35 Class 8.8 Set Screw Z/P	8
11	45139	M12 Nyloc Nut Z/P	8
12	61136	LH Pedestal Welded Assembly	1
13	27935	Calibration Tray	2
14	Refer pages 50	Drive Pedestal Complete Assembly	1
15	45159	M12 HD Washer Z/P	8
16	61124	Crank Handle Assembly	1
17	45040	M16 x 50 Class 8.8 Bolt Z/P	4
18	45140	M16 Nyloc Nut Z/P	4
19	45160	M16 HD Washer Z/P	4
20	43697	Wheel Assembly	2
21	Refer Pages 70	Eco Seeder Disc Openers (Optional)	1
22	Refer Pages 48	Tine Assembly	16 18
23	25730	Jockey Arm Tension Spring	1
24	27888	Jockey Arm Eyebolt	1
25	45131	M12 Hex Nut Z/P	2
26	45167	M12 Spring Washer Z/P	1

'EcoSeeder' Seed Drill Single Box Complete Assy

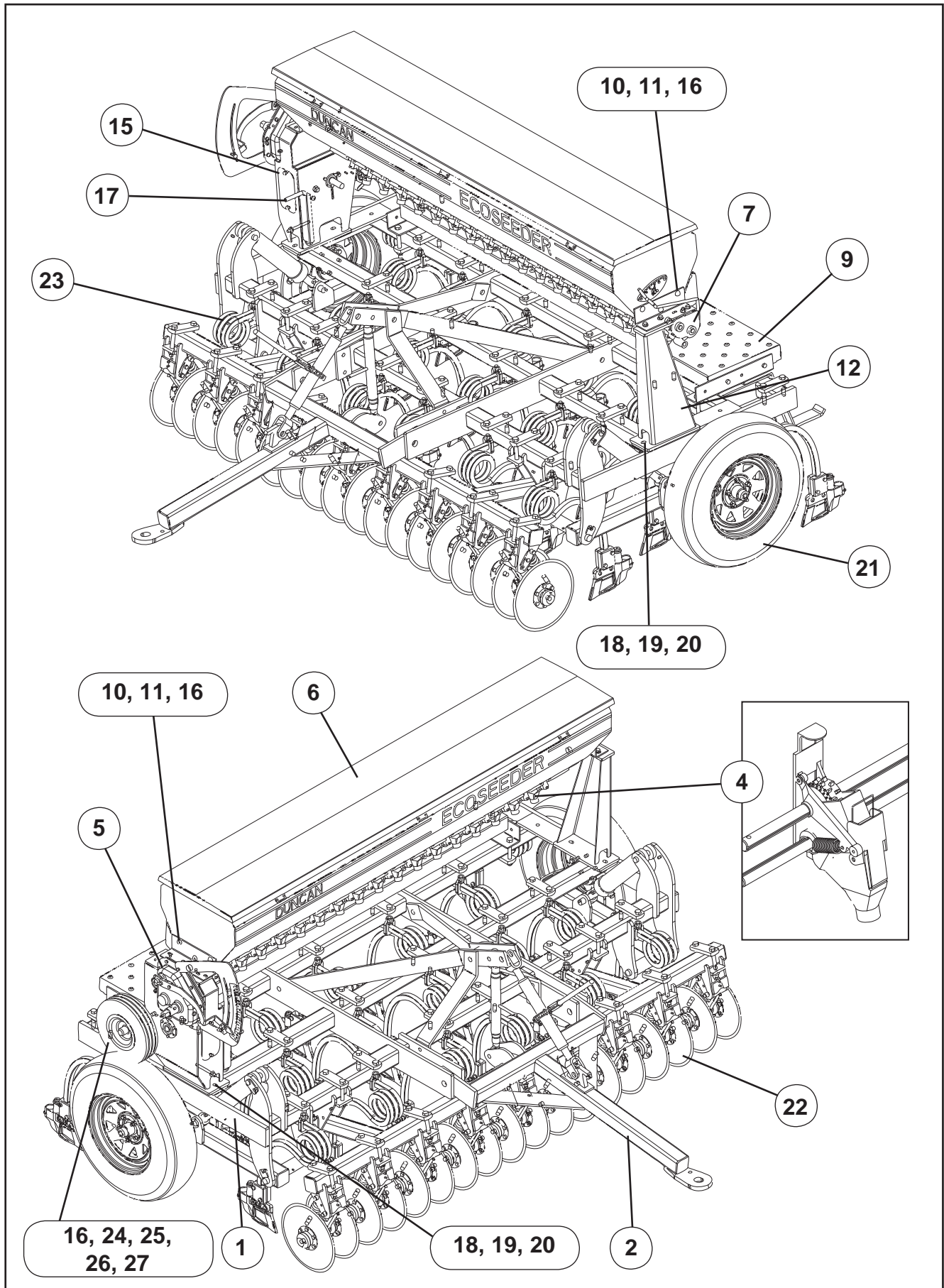

'EcoSeeder' Seed Drill Single Box Complete Assy

ITEM	PART No.	DESCRIPTION	QTY
1	Refer pages 44	Main Frame Assembly	1
2	Refer pages 44	Drawbar Assembly (Optional)	1
3	Refer pages 69	Hectaremeter Kit (Optional - not shown)	1
4	Refer pages 59	Seeder Mechanism	14 16 18
5	Refer pages 55	Gearbox Final Assembly	1
6	Refer pages 64	Seedbox Assembly	1
7	Refer pages 66	Agitator drive	1
8	Refer pages 67	Agitator Shaft Assembly (Inside Seedbox)	1
9	Refer pages 68	Footboard Arrangement	1
10	45019S	M12 x 35 Class 8.8 Set Screw Z/P	6
11	45139	M12 Nyloc Nut Z/P	6
12	61140	LH Pedestal Welded Assembly	1
13	61212	Calibration Tray 14 Run	1
14	27935	Calibration Tray 16/18 Run	1
15	Refer pages 51	Drive Pedestal Complete Assembly	1
16	45159	M12 HD Flat Washer Z/P	6
17	61124	Crank Arm Assembly	1
18	45040	M16 x 50 Class 8.8 Bolt Z/P	4
19	45136	M16 Nyloc Nut Z/P	4
20	45160	M16 HD Flat Washer Z/P	4
21	43697	Wheel Assembly	2
22	Refer pages 70	Eco Seeder Disc Openers	1
23	Refer pages 48	Tine Assembly	14 16 18
24	25730	Jockey Arm Tension Spring	1
25	25723	Jockey Arm Tension Eyebolt	1
26	45131	M12 Hex Nut Z/P	2
27	45167	M12 Spring Washer Z/P	1

'EcoSeeder' Seed Drill Mainframe and Drawbar

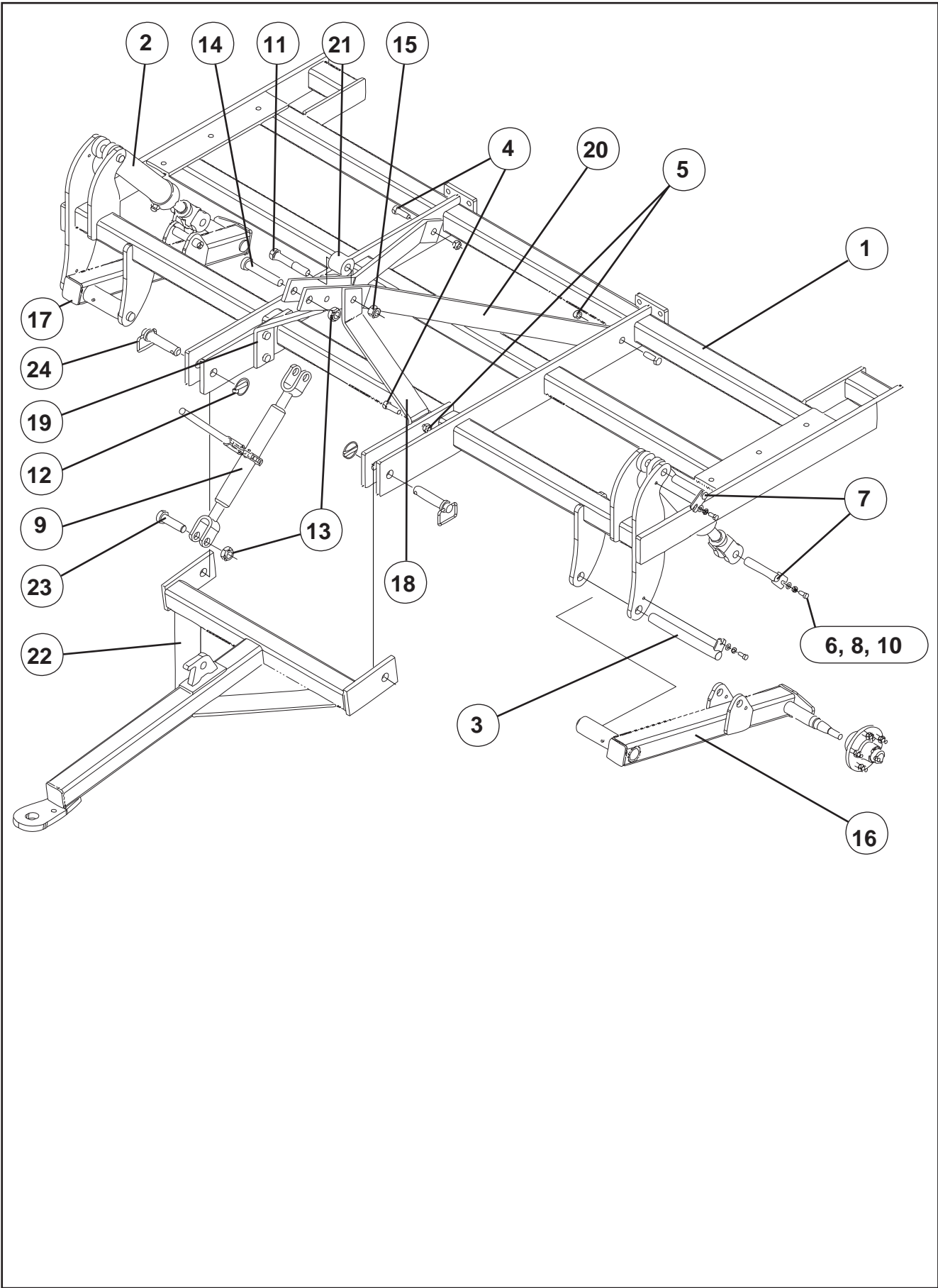

'EcoSeeder' Seed Drill Mainframe and Drawbar

ITEM	PART No.	DESCRIPTION	QTY	QTY
1	61102	14R Mainframe	1	1
1	27850	16R Mainframe	1	1
1	61100	18R Mainframe	1	1
2	Refer Pages 46	Hydraulic Ram	2	0
3	27986	Pivot Pin Welded Assembly	2	2
4	45040	M16 x 50 Class 8.8 Bolt Z/P	4	4
5	45140	M16 Nyloc Nut Z/P	4	4
6	45002S	M10 x 25 Class 8.8 Set Screw Z/P	6	6
7	22262	Clevis Pin Assembly (Tapped)	4	4
8	45166	M10 Spring Washer Z/P	6	6
9	43395	Heavy Duty Ratchet Turnbuckle	1	2
10	45152	M10 Light Flat Washer Z/P	6	6
11	47237	7/8" x 5 1/2" UNF HT Bolt Z/P	1	1
12	45292	7/16" x 1 1/2" Lynch Pin	2	2
13	47552	1" UNF Nyloc Nut Z/P	2	0
14	47254	1" x 5" UNF HT Bolt Z/P	1	0
15	47548	7/8" UNF Nyloc Nut Z/P	1	1
16	Refer Pages 47	LH Wheel Leg Assembly	1	1
17	Refer Pages 47	RH Wheel Leg Assembly	1	1
18	27550	LH Link Support Stay	1	1
19	27551	RH Link Support Stay	1	1
20	27861	Rear Link Stay	2	2
21	27778	Top Link Spacer Assembly	1	1
22	27960	Drawbar Assembly	1	0
23	47251	1" x 3 1/2" UNF HT Bolt Z/P	1	0
24	45295	Cat 2 x 4-1/4" Clevis Pin	2	2

'EcoSeeder' Seed Drill Hydraulic Ram

ITEM	PART No.	DESCRIPTION	QTY
1	43977	2.5" x 8" x 1.5" Hydraulic Ram	2
2	27970	Hydraulic Hose x 1.32m	2
3	27971	Hydraulic Hose x 2.52m	1
4	61258	Hydraulic Block Assembly	1
5	43280	3/4" UN'O' to 3/8" BSP Nipple	3
6	43152	3/4" UN'O' 3/8" BSPM Silencer Assembly	2
7	43147	1/2" BSP Quick Release Coupling	1
8	43617	1/2" Male Probe Dust Cover	1
9	43496	3/8" BSPTM 3/8" BSPF Swivel 90° Elbow	2
10	43499	Whoa Stop Collar Set (Not Shown)	2
11	43392	3/8" BSPP M/M Nipple	1
12	43391	3/8" Dowty Washer	2
13	43393	3/8" S/Steel Ball Valve	1
14	43445	1/2" BSPT to 3/8" BSPP M/M Nipple	1

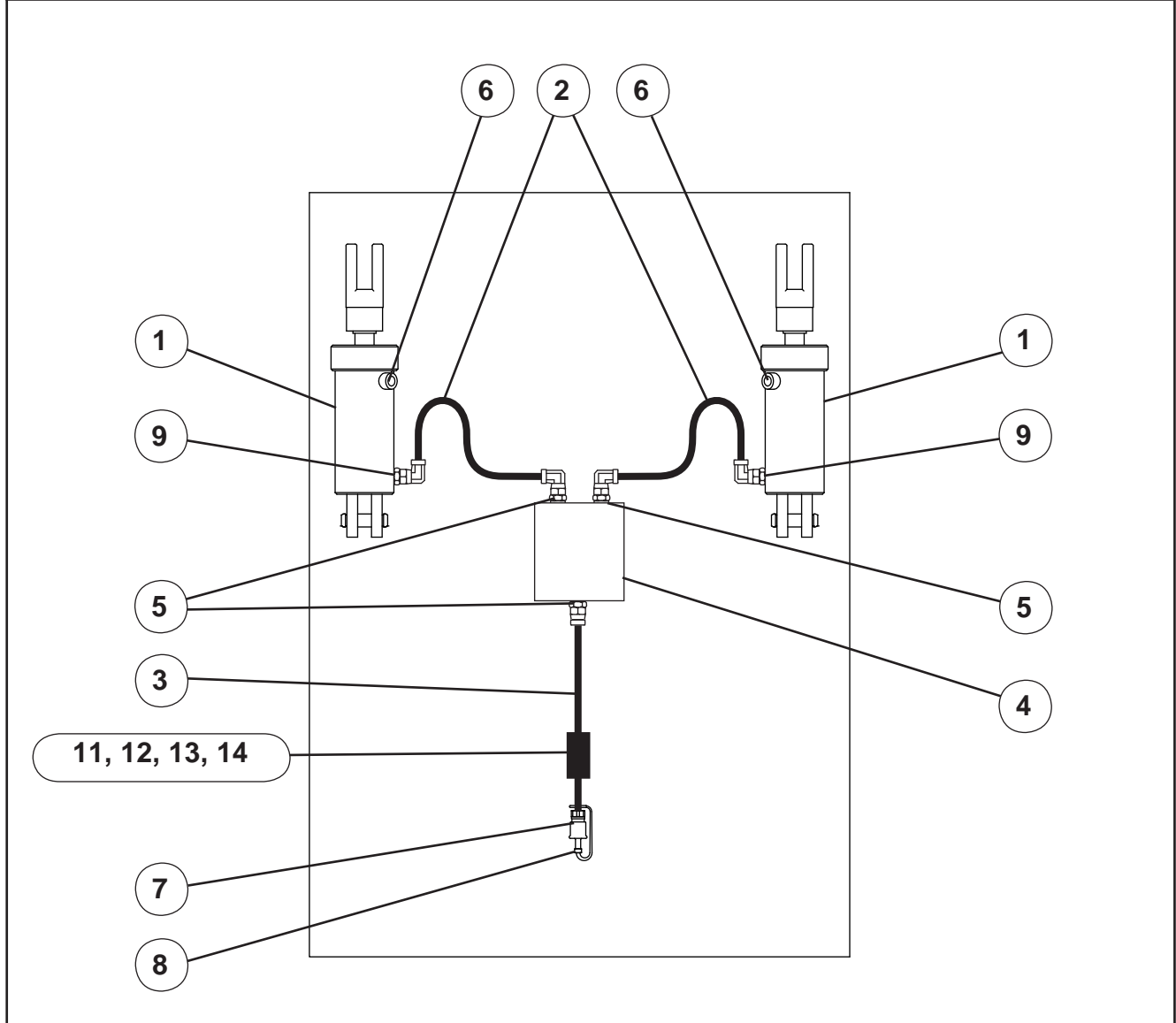

'EcoSeeder' Seed Drill Wheel Leg Assembly

ITEM	PART No.	DESCRIPTION	QTY
1	27865	Left Hand Wheel Leg	1
1	27866	Right Hand Wheel Leg (not shown)	1
2	19064	Plastic Bush	2
3	18607	Wheel stud & Nut	5
4	27872	1500kg Hub & Bearing Set	1
5	43412	Inner Bearing (Spares Only)	-
6	30348	Outer Bearing (Spares Only)	-
7	43802	Marine Oil Seal & Retainer	1
8	45155	M20 Light Flat Washer Z/P	1
9	45313	5 Dia x 50 Long Cotter pin	1
10	47506	3/4" UNF Castle Nut Z/P	1
11	43041	Dust Cap	1
12	43118	Grease Nipple Straight	1

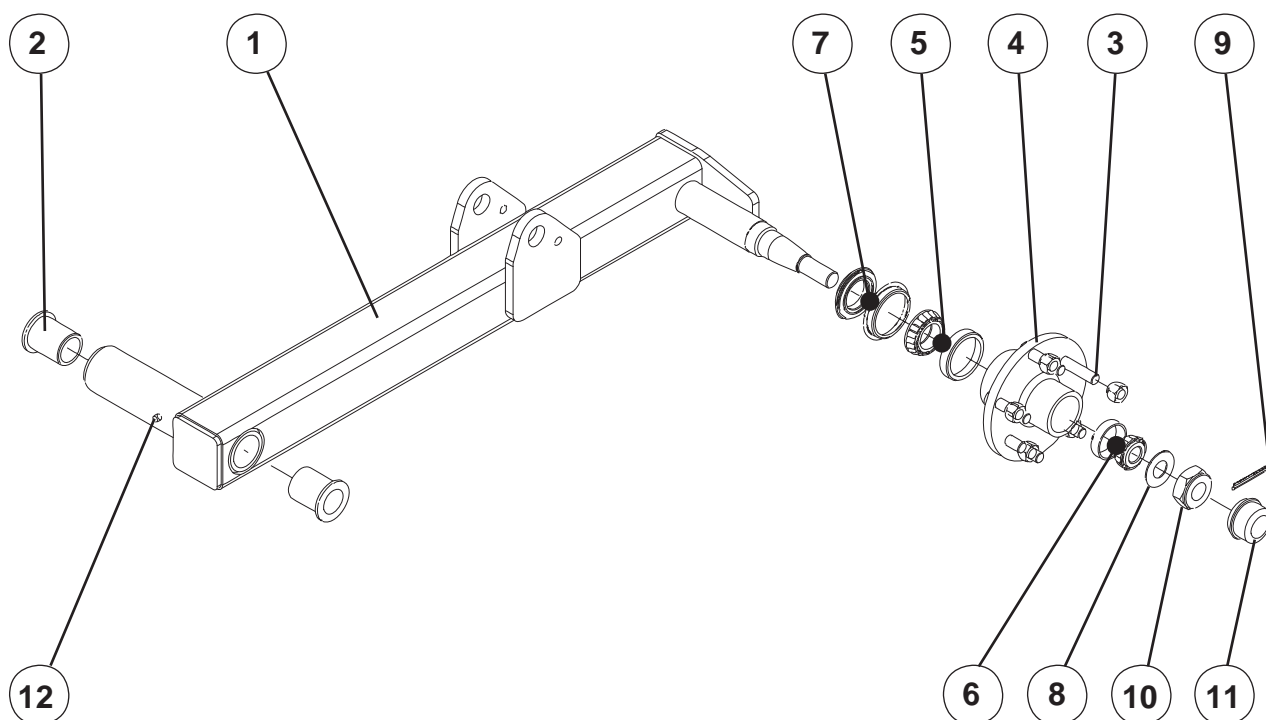

'EcoSeeder' Seed Drill Tine and Boot Assembly

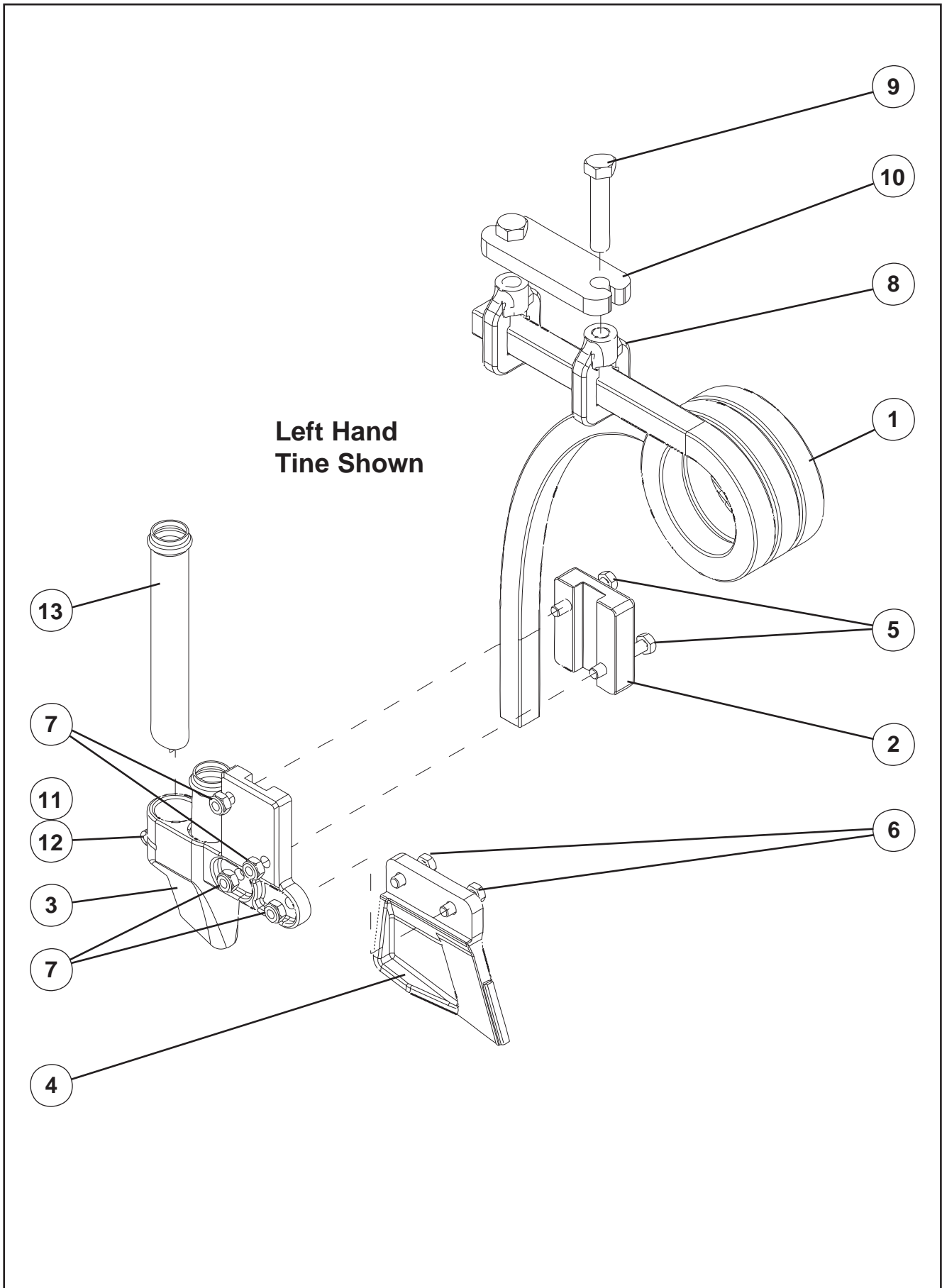

'EcoSeeder' Seed Drill Tine and Boot Assembly

ITEM	PART No.	DESCRIPTION	SINGLE			DUAL	
			14R	16R	18R	16R	18R
1	21413	LH Coil Tine	7	8	9	8	9
1	21414	RH Coil Tine	7	8	9	8	9
2	26848	LH Inverted Tee Clamp	14	16	18	16	18
3	25615	RH Inverted Tee Clamp	14	16	18	16	18
4	26849	Tiled Nihard Inverted Tee Point	14	16	18	16	18
5	45010	M10 x 65 Class 8.8 Bolt Z/P	28	32	36	32	36
6	45003	M10 x 30 Class 8.8 Bolt Z/P	28	32	36	32	36
7	45138	M10 Nyloc Nut Z/P	56	64	72	64	72
8	21691	Tine Clamp Casting	28	32	36	32	36
9	45046	M16 x 80 Class 8.8 Bolt Z/P	28	32	36	32	36
10	21690	75 x 75 RHS Clamp Plate	14	16	18	16	18
11	44962	M8 x 35 Class 8.8 Bolt Z/P	-	-	-	16	18
12	45137	M8 Nyloc Nut Z/P	-	-	-	16	18
13	25608	Fertilizer Tube Standard	-	-	-	16	18
14	43691	Feed Hose 38mm (not shown)	-				
15	43500	Cray Clip 47-49mm (fitted to top of hose, not shown)	14	16	18	16	18

'EcoSeeder' Seed Drill Dual Box Drive Pedestal

ITEM	PART No.	DESCRIPTION	QTY
1	Refer Pages 54	Dual Output Gearbox Complete Assembly	1
2	22281P	Cover Plate Large	1
3	25979P	Cover Plate Small	2
4	44992S	M8 x 20 Class 8.8 Set Screw	6
5	45165	M8 Spring Washer	6
6	Refer Pages 60	Jockey Wheel Assembly	1
7	Refer Pages 60	Drive Pedestal Shaft	1
8	Refer Pages 58	Seedbox Drive Shaft	1
9	61124	Crank Handle	1
10	61114	Drive Pedestal Welded Assembly	1
11	45157	M8 Heavy Duty Flat Washer	6
12	22050	Crank Adaptor Assembly	1
13	45180	M8 x 10 Socket Head Grub Screw	2
14	22294	Sprocket Key (6X6x25)	1

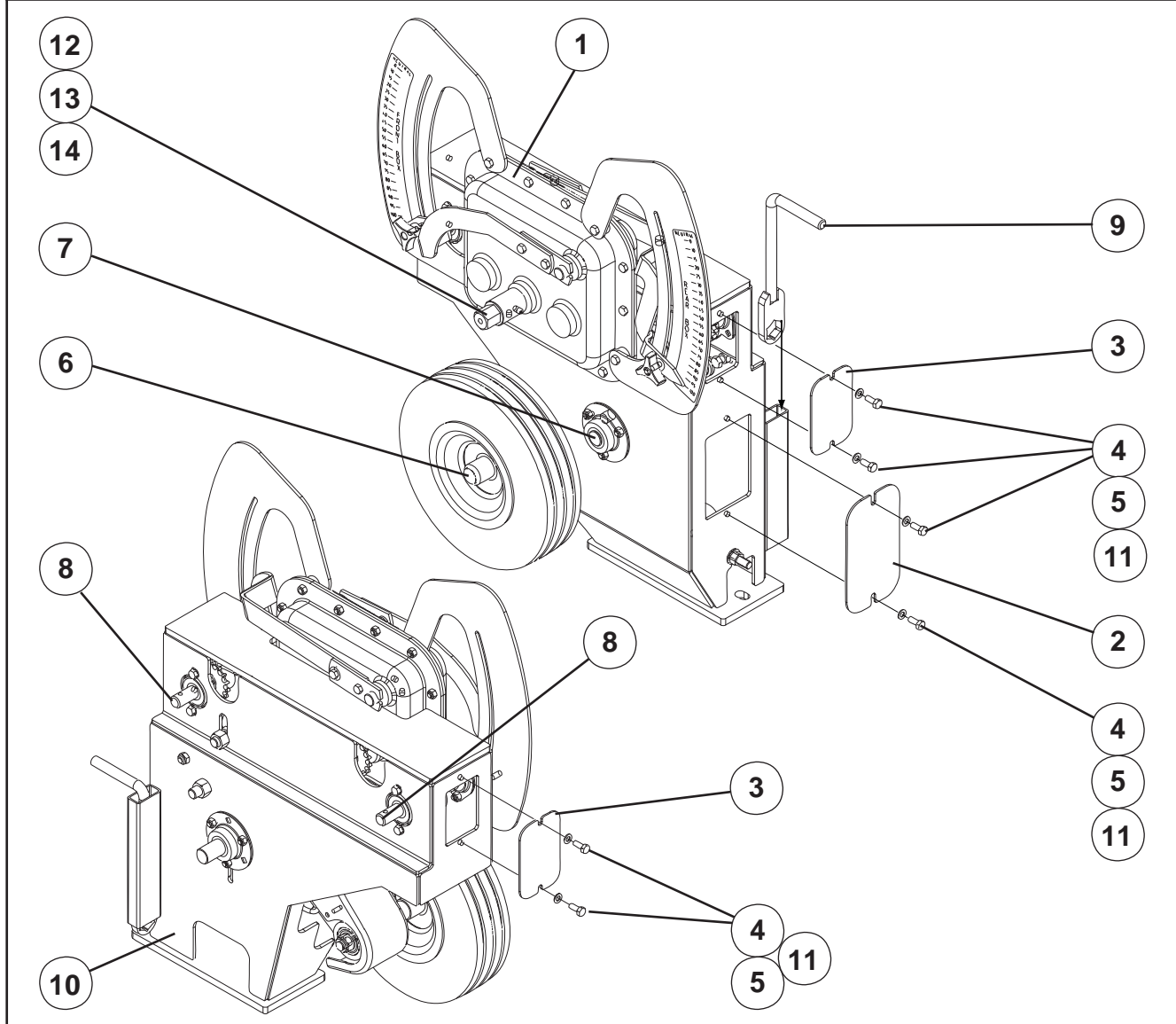

'EcoSeeder' Seed Drill Single Box Drive Pedestal

ITEM	PART No.	DESCRIPTION	QTY
1	Refer Pages 55	Single Output Gearbox Complete Assembly	1
2	22281P	Cover Plate	2
3	44992S	M8 x 20 Class 8.8 Set Screw Z/P	4
4	45165	M8 Spring Washer Z/P	4
5	Refer Pages 60	Jockey Wheel Assembly	1
6	Refer Pages 60	Drive Pedestal Shaft	1
7	Refer Pages 58	Seedbox Drive Shaft	1
8	61124	Crank Handle	1
9	61129	Drive Pedestal Welded Assembly	1
10	45157	M8 HD Flat Washer Z/P	4
11	22050	Crank Adaptor Assembly	1
12	45180	M8 x 10 Socket Head Grub Screw	2
13	22294	Sprocket Key (6x6x25)	1

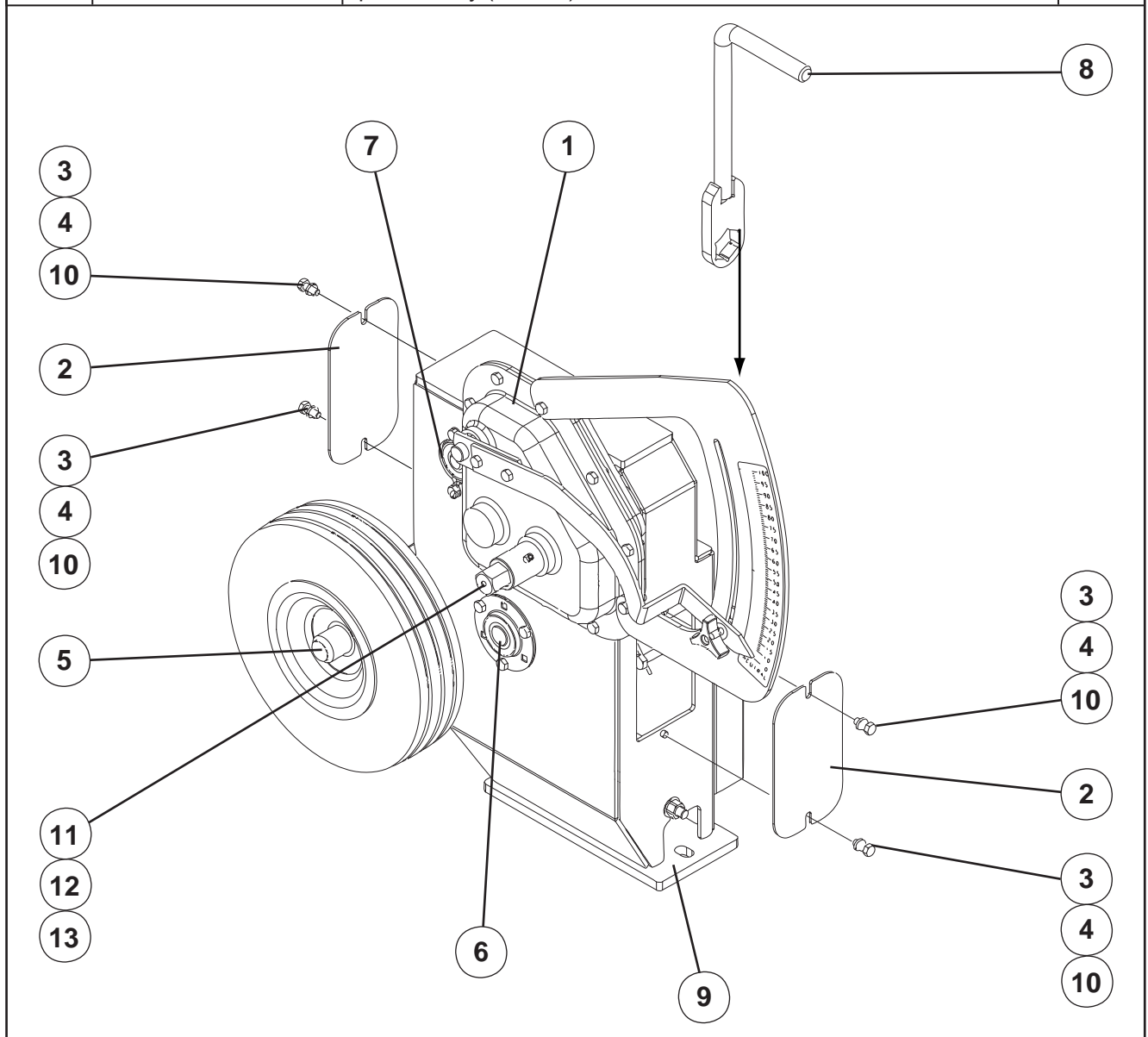

'EcoSeeder' Seed Drill Drive Chains Dual Box

ITEM	PART No.	DESCRIPTION	QTY
1	25724	13 T Sprocket 1/2" P x 20mm Bore	1
2	25742	38 T Sprocket 1/2" P x 25mm Bore	1
3	27885	13 T Sprocket 1/2" P x 25mm Bore	1
4	27311	21 T Sprocket 1/2" P x 25mm Bore	1
5	22044	15 T Sprocket 1/2" P x 20mm Bore	3
6	22537	25 T Sprocket 1/2" P x 20mm Bore	1
7	24103	1/2"P BS Chain x 61 Links (Jockey Wheel Drive)	1
8	22466	1/2"P BS Chain x 55 Links (Transfer Shaft to Gearbox input)	1
9	61262	1/2"P BS Chain x 35 Links (Gearbox to Front Boxshaft)	1
10	27934	1/2"P BS Chain x 41 Links (Gearbox to Rear Boxshaft)	1
11	Refer page 56	Chain Tensioner Jockey Wheel Drive	1
12	Refer page 56	Chain Tensioner Transfer Drive	1
13	22294	Sprocket Key (6 x 6 x 25) (Not Shown)	8
14	43388	1/2" Pitch Joining Link	4
15	43389	1/2" Pitch Half Link	2

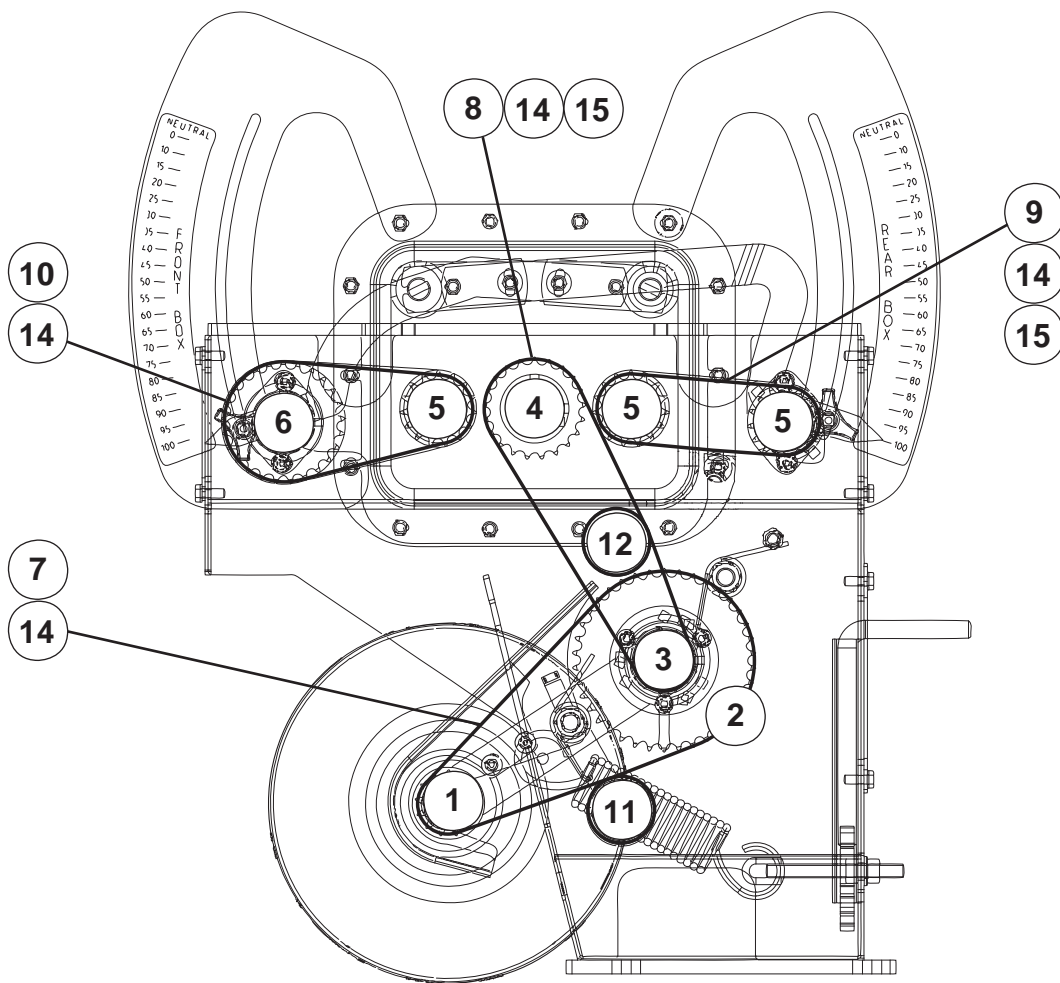

'EcoSeeder' Seed Drill Drive Chains Single Box

ITEM	PART No.	DESCRIPTION	QTY
1	25724	13 T 1/2" P Sprocket x 20mm Bore	1
2	25742	38 T 1/2" P Sprocket x 25mm Bore	1
3	27885	13 T 1/2" P Sprocket x 25mm Bore	1
4	22044	15 T 1/2" P Sprocket x 20mm Bore	1
5	26198	21 T 1/2" P Sprocket x 25mm Bore	1
6	22537	25 T 1/2" P Sprocket x 20mm Bore	1
7	25781	1/2" P BS Chain x 37 Links (Gearbox to Boxshaft)	1
8	27652	1/2" P BS Chain x 53 Links (Transfer Shaft to Gearbox input)	1
9	24103	1/2" P BS Chain x 61 Links (Jockey Wheel Drive)	1
10	Refer page 57	Chain Tensioner Jockey Wheel Drive	1
11	Refer page 57	Chain Tensioner Transfer Drive	1
12	22294	Sprocket Key (6 x 6 x 25) (Not Shown)	6
13	43388	1/2" Pitch Joining Link	3

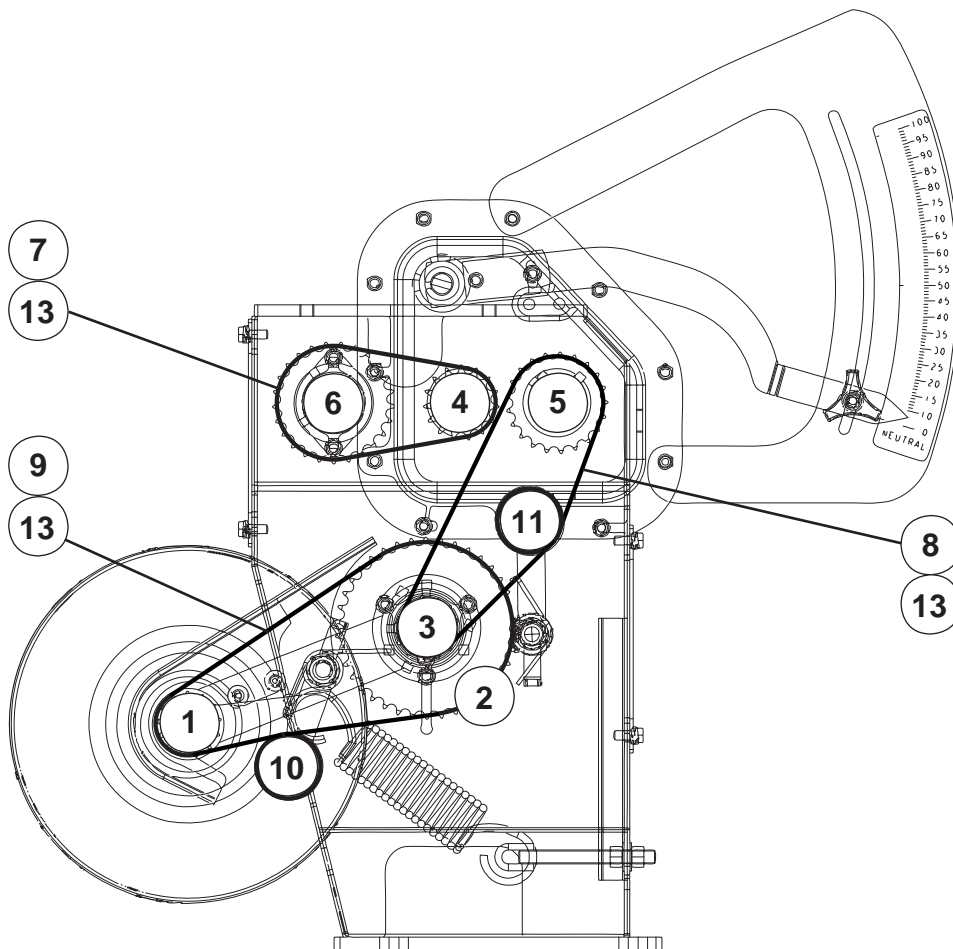

'EcoSeeder' Seed Drill Dual Gearbox Assembly

ITEM	PART No.	DESCRIPTION	QTY
1	25756	Gearbox Sub-Assembly	1
2	22036	Quadrant, Speed Adjusting	2
3	25754	Lever, Front, Speed Adjusting	1
4	25755	Lever, Rear, Speed Adjusting	1
5	43366	M8 Tri-Knob Tapped Centre	2
6	47031	M8 x 30 Class 4.6 Cup Head Coach Bolt Z/P	2
7	45151	M8 Light Flat Washer Z/P	2
8	22041	Front Box Speed Indicator Label (black writing on yellow background)	1
9	22042	Rear Box Speed Indicator Label (yellow writing on black background)	1
10	44992S	M8 x 20 Class 8.8 Set Screw Z/P	10
11	44993S	M8 x 25 Class 8.8 Set Screw Z/P	6
12	45157	M8 HD Flat Washer Z/P	2
13	45137	M8 Nyloc Nut Z/P	16
14	25762	Gearbox Final Assembly (Includes items 1 to 13)	1

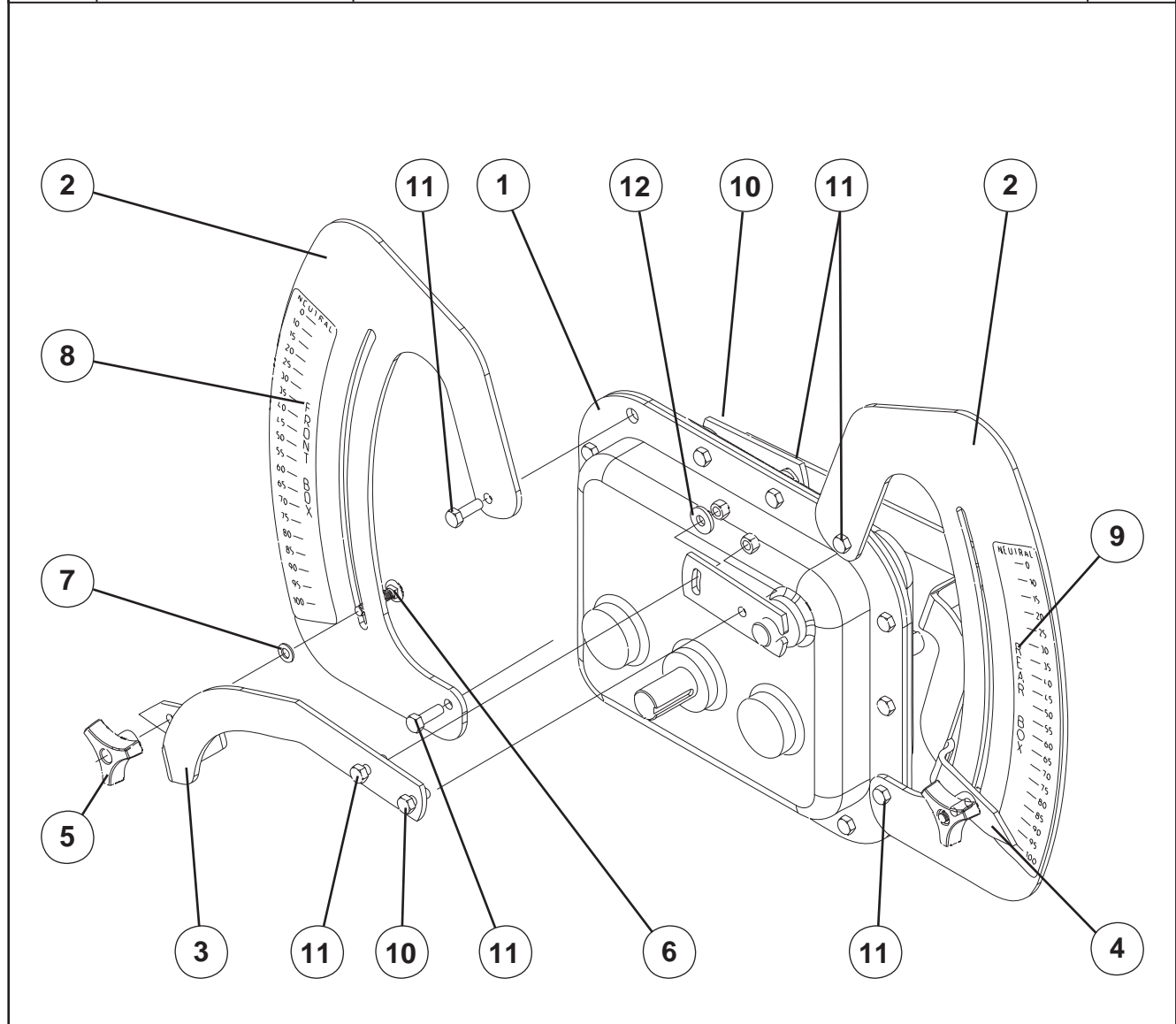

'EcoSeeder' Seed Drill Single Gearbox Assembly

ITEM	PART No.	DESCRIPTION	QTY
1	27900	Single Output Gearbox Sub-Assembly	1
2	23616	Speed Adjusting Quadrant	1
3	23615	Speed Adjusting Lever	1
4	43366	M8 Tri-Knob Tapped Centre	1
5	47031	M8 x 30 Class 4.6 Cup Head Coach Bolt Z/ P	1
6	45151	M8 Light Flat Washer Z/P	1
7	22042	Rear Box Speed Indicator Label (yellow writing on black background)	1
8	44992S	M8 x 20 Class 8.8 Set Screw Z/P	1
9	44993S	M8 x 25 Class 8.8 Set Screw Z/P	3
10	45157	M8 HD Flat Washer Z/P	1
11	45137	M8 Nyloc Nut Z/P	4
12	27899	Gearbox Final Assembly (Includes items 1 to 11)	1

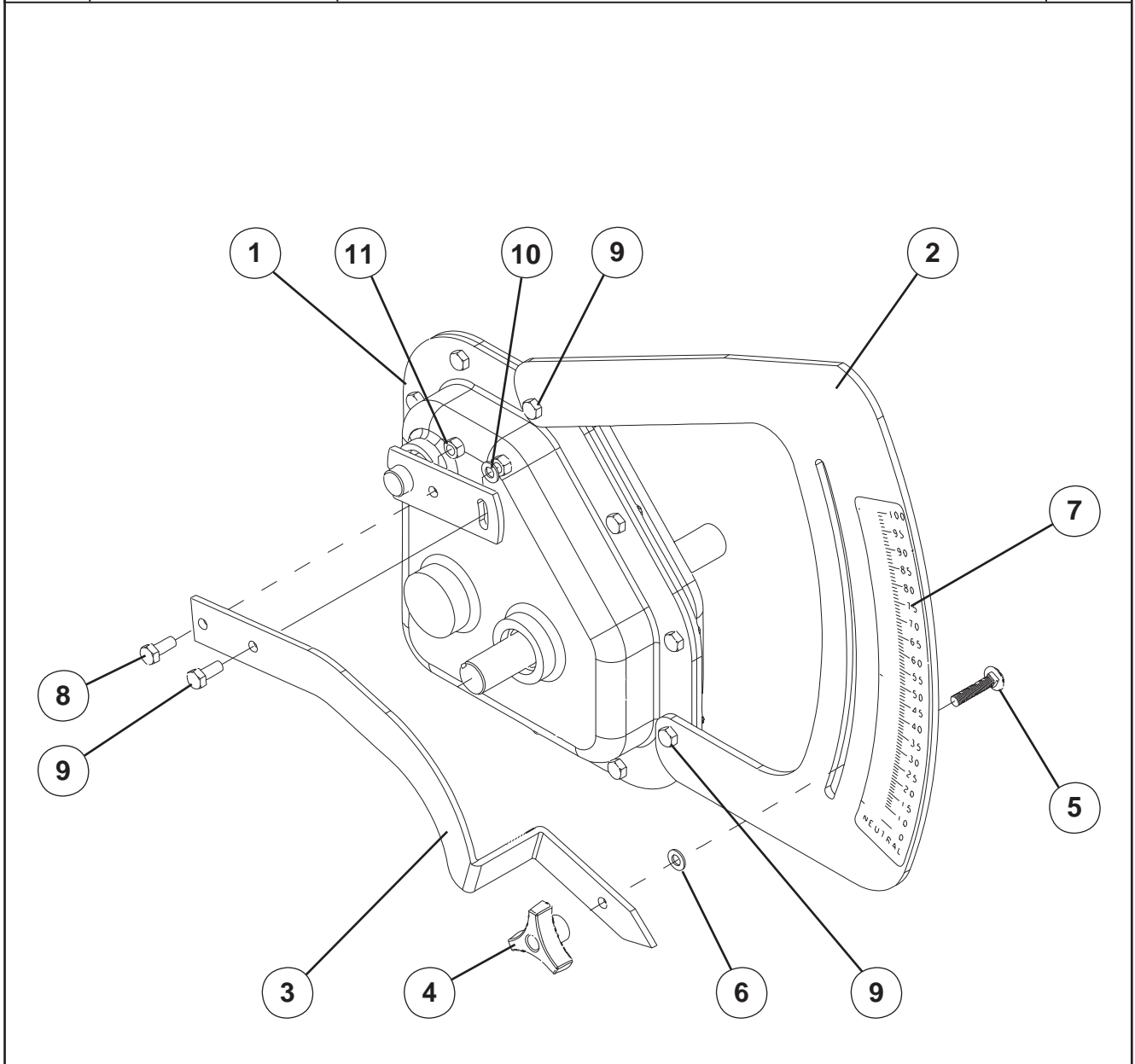

'EcoSeeder' Seed Drill Chain Tensioner Dual Box

ITEM	PART No.	DESCRIPTION	QTY
1	22535	Nylon Roller	2
2	23373	Chain Tensioner Short	2
3	22523	Torsion Spring, RH	1
4	23376	Chain Tensioner Anchor 30mm Extension	1
5	24106	Chain Tensioner Anchor 50mm Extension	1
6	45140	M16 Nyloc Nut Z/P	1
7	45043	M16 x 65 Class 8.8 Bolt Z/P	1
8	45119	M16 Hex Half Nut Z/P	2
9	61261	M16 x 120 Class 8.8 Bolt Z/P (85mm Thread)	1
10	22522	Torsion Spring, LH	1
11	45160	M16 HD Washer	1

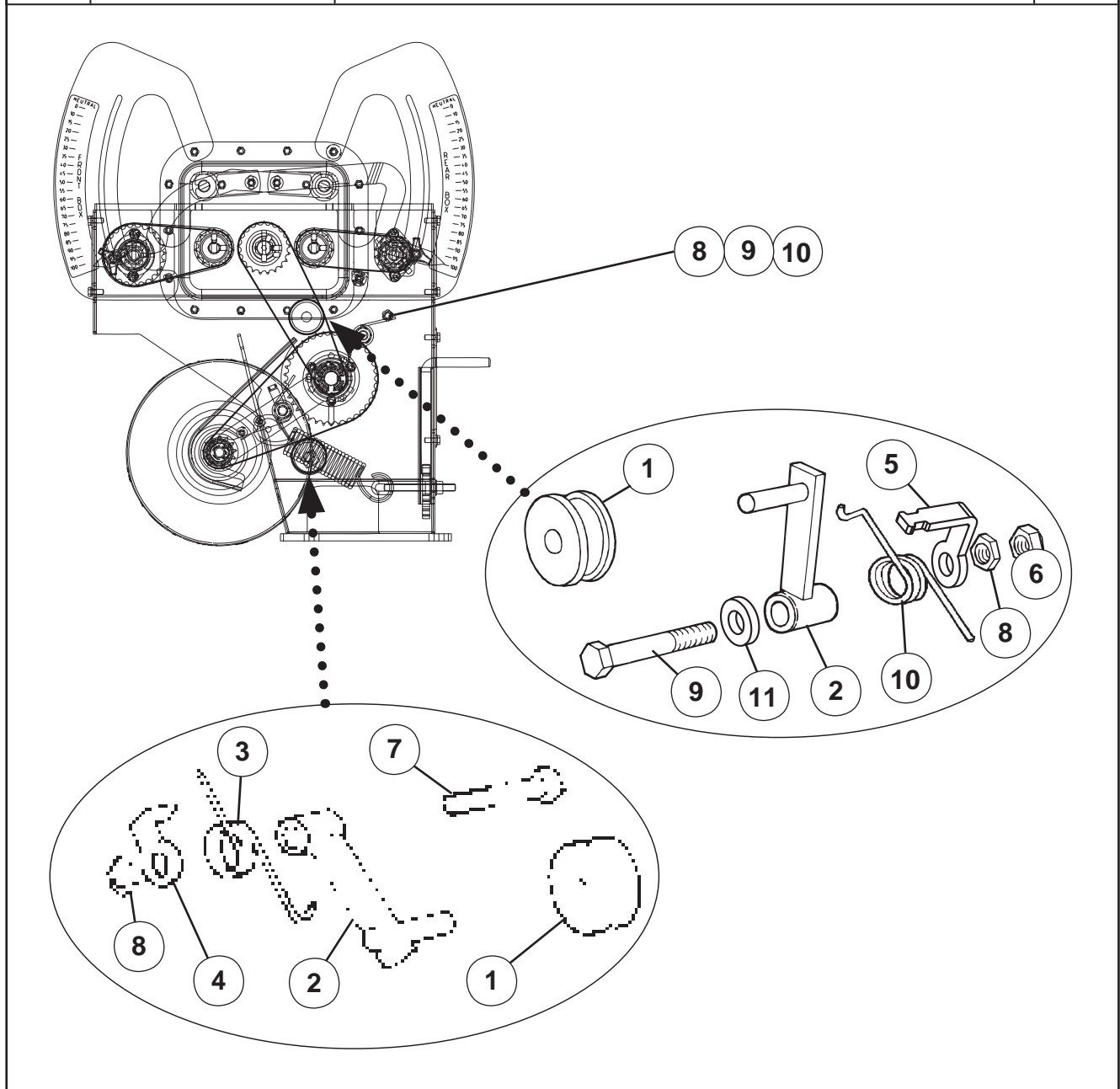

'EcoSeeder' Seed Drill Chain Tensioner Single Box

ITEM	PART No.	DESCRIPTION	QTY
1	22535	Nylon Roller	2
2	22480	Chain Tensioner Arm Assembly	1
3	23373	Chain Tensioner Short Arm Assembly	1
4	22523	Torsion Spring, RH	1
5	23376	Chain Tensioner Anchor	1
6	45140	M16 Nyloc Nut Z/P	1
7	45043	M16 x 65 Class 8.8 Bolt Z/P	2
8	45119	M16 Hex Half Nut Z/P	2
9	61261	M16 x 120 Bolt C/W 85mm Thread	1
10	45160	M16 H/D Flat Washer Z/P	1
11	22522	Torsion Spring Left Hand	1
12	24106	Chain Tensioner Anchor 50 Ext	1
13	61260	Chain Tensioner Spacer (50mm)	1

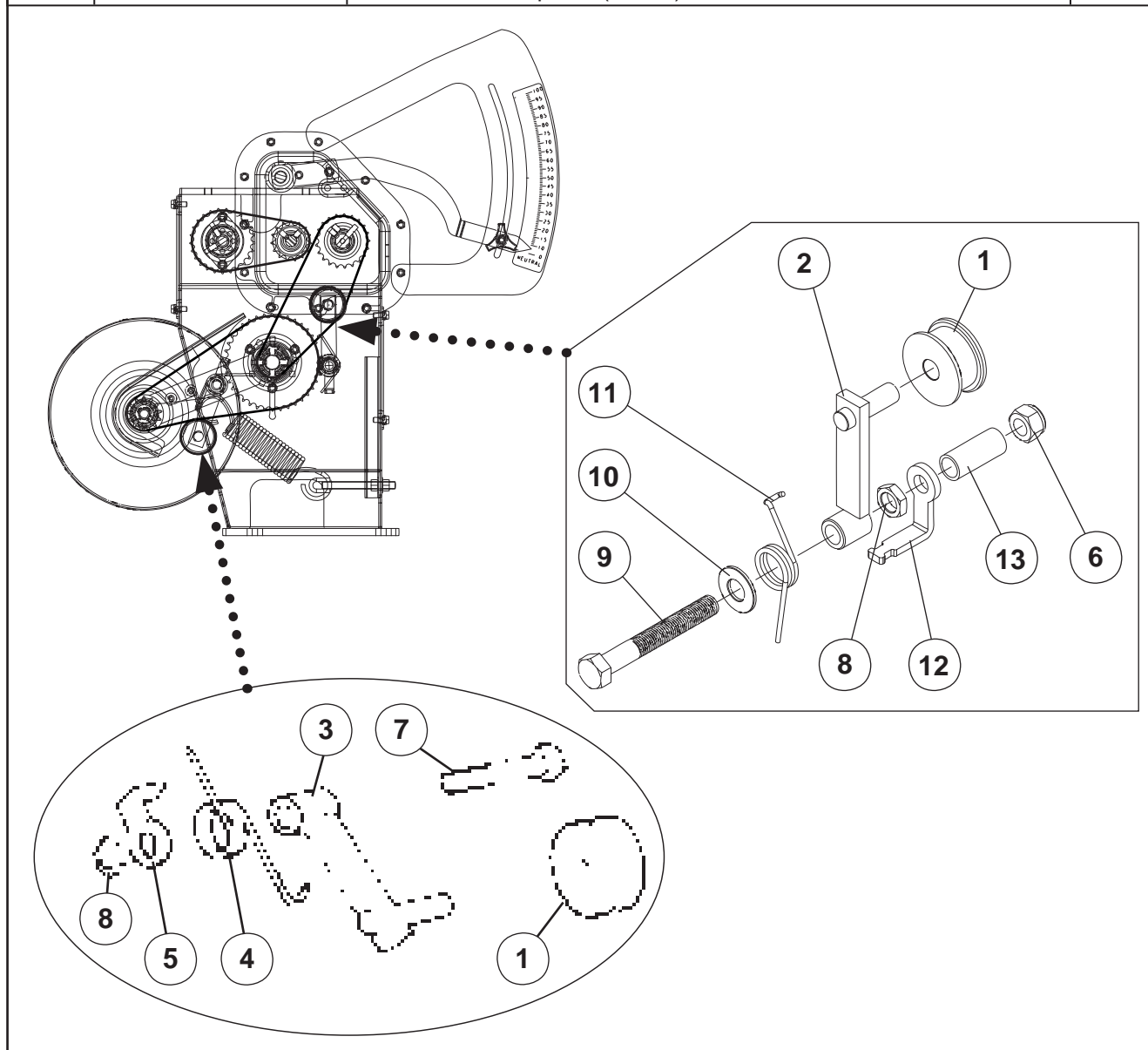

'EcoSeeder' Seed Drill Seed Box Drive Shafts

ITEM	PART No.	DESCRIPTION	QTY
1	22044	15T x 1/2"P Sprocket 20mm Bore (Front Box)	1
1	22537	25T x 1/2"P Sprocket 20mm Bore (Rear Box & Single Box)	1
2	22294	Sprocket Key (6 x6 x 25)	2
3	27886	Box Drive Shaft	2
4	43385	"Y" Bearing	4
5	43387	Bearing Housing Pressed Steel (2 Flanges = 1 Housing)	4
6	45411S	M8 x 20 Class 8.8 Set Screw Z/P	8
7	45137	M8 Nyloc Nut Z/P	8
8	45180	M8 x 10 Socket Head Grubscrew	2
9	45151	M8 Light Flat Washer	8

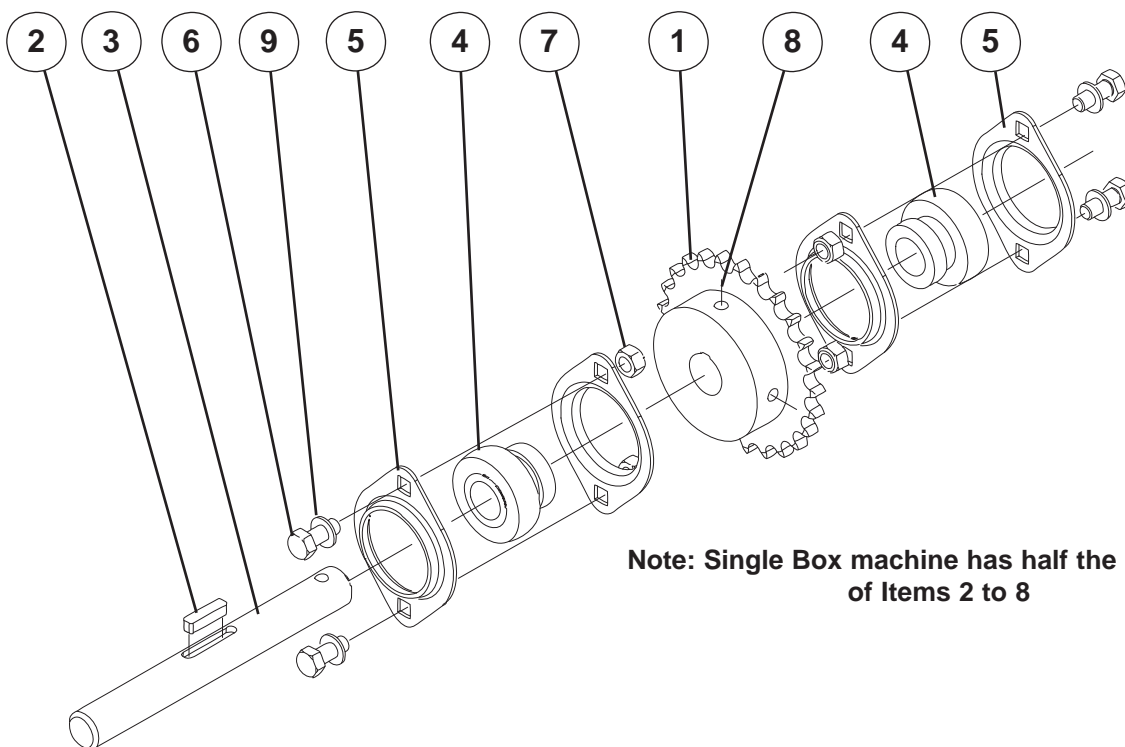

Note: Single Box machine has half the quantities of Items 2 to 8

'EcoSeeder' Seed Drill Seeder Mechanism

ITEM	PART No.	DESCRIPTION	SINGLE			DUAL	
			14R	16R	18R	16R	18R
1	43375	Metering Housing	14	16	18	32	36
2	43376	Shutter Slide	14	16	18	32	36
3	43377	Seed Metering Wheel (includes item 4)	14	16	18	32	36
4	43374	Fine Seed Wheel (for spares ordering only)					
5	43378	Bottom Flap & Bolt Assembly	14	16	18	32	36
6	22550	Seeder Extension Funnel	14	16	18	32	36
7	22551	Seed Diverter	14	16	18	32	36
8	22548	Spring Clip S/S	14	16	18	32	36
9	43379	Seed Shaft Guide Bearing	2	2	2	4	4
10	43380	Guide Bearing Tension Spring	2	2	2	4	4
11	43382	Metering Wheel Clutch Hook	1	1	1	1	1
12	43383	Seed Rate Disc Calculator	1	1	1	1	1
13	43362	Fine Seed Wheel Brush (Optional Extra)					

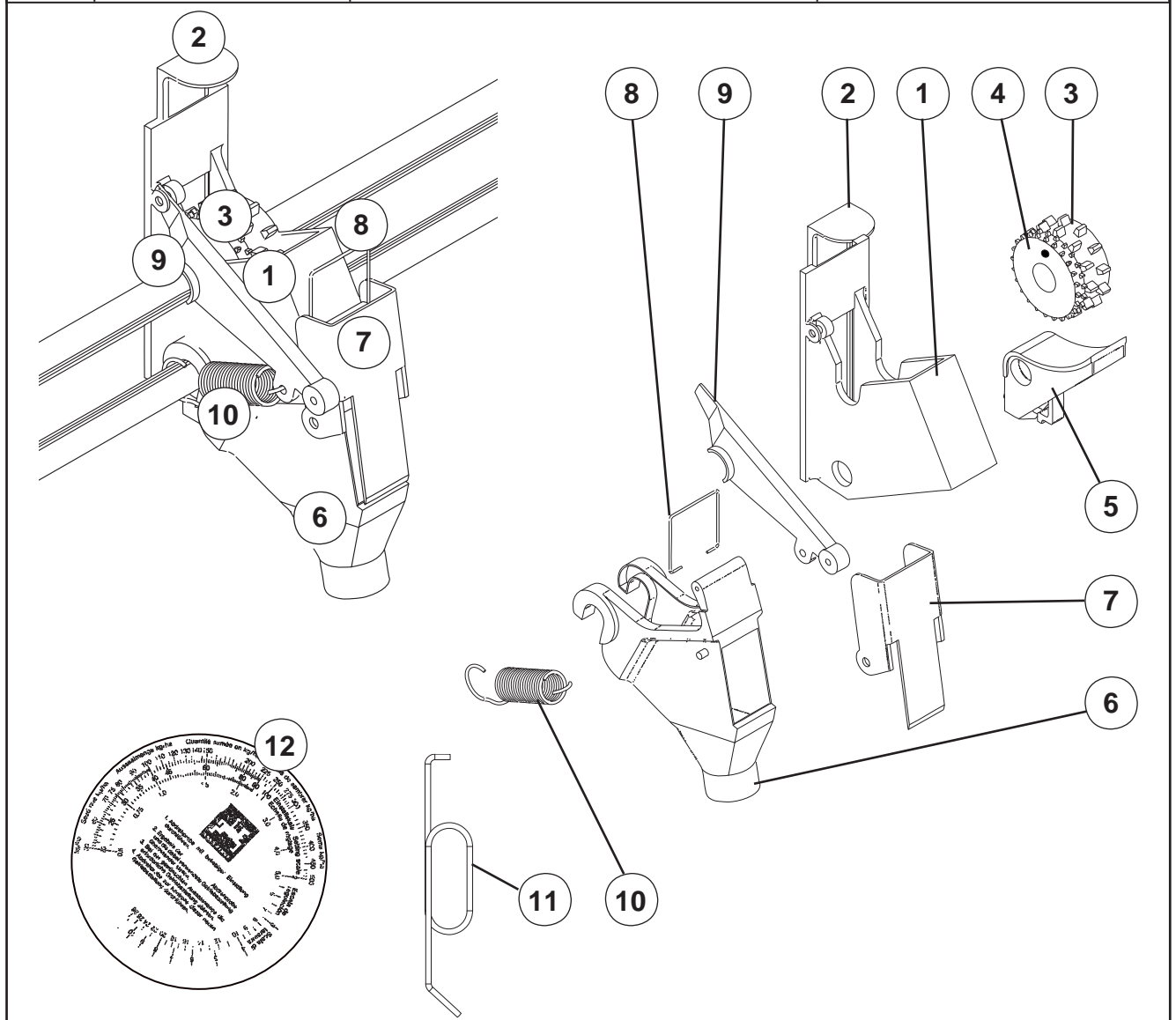

'EcoSeeder' Seed Drill Jockey Drive

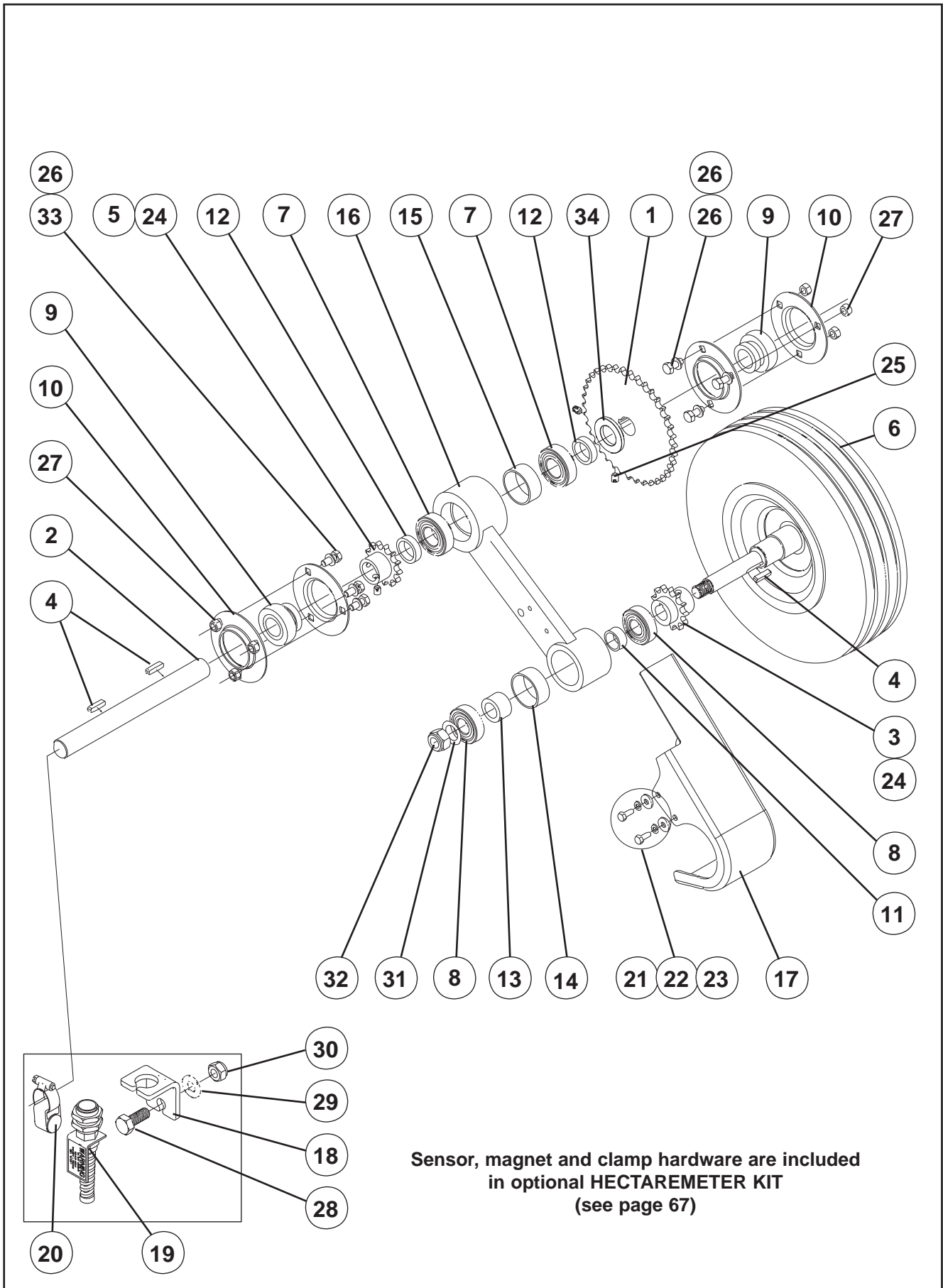

‘EcoSeeder’ Seed Drill Jockey Drive

ITEM	PART No.	DESCRIPTION	QTY
1	25742	38T x 1/2" P Sprocket 25mm Bore	1
2	27887	Transfer Drive Shaft	1
3	25724	13T x 1/2" P Sprocket 20mm Bore	1
4	22294	Sprocket Key (6x6x25)	3
5	27885	13T 1/2"P Sprocket 25mmBore	1
6	25744	Jockey Wheel and Axle Assembly	1
7	43036	Drive Pedestal Transfer Shaft Bearing	2
8	17127	Jockey Wheel Axle Bearing	2
9	43386	"Y" Bearing	2
10	30359	3 Bolt Bearing Housing, PF52, (2 Flanges = 1 Housing)	2
11	25726	Jockey Drive Axle Spacer	1
12	25725	Jockey Arm Pivot Spacer	2
13	25739	Jockey Axle Inner Spacer	1
14	25727	Jockey Axle Outer Spacer (Loctite in place when fitted)	1
15	25729	Jockey Arm Pivot Outer Spacer (Loctite in place when fitted)	1
16	25735	Jockey Wheel Arm	1
17	25746	Jockey Drive Swing Guard	1
18	23410	Sensor Mount Bracket Optional with Hectaremeter Kit	1
19	43403	Sensor (with locknuts) Optional with Hectaremeter Kit	1
20	43404	Magnet and Clamp Optional with Hectaremeter Kit	1
21	44951S	M6 x 16 Class 8.8 Set Screw Z/P	2
22	45164	M6 Spring Washer Z/P	2
23	45156	M6 HD Flat Washer Z/P	2
24	45180	M8 x 10 Socket Head Grubscrew	4
25	45186	M10 x 12 Socket Head Grubscrew	2
26	44992S	M8 x 20 Class 8.8 Set Screw Z/P	6
27	45137	M8 Nyloc Nut Z/P	6
28	45001S	M10 x 20 Class 8.8 Set Screw Z/P Optional with Hectaremeter Kit	1
29	45152	M10 Light Flat Washer Z/P Optional with Hectaremeter Kit	1
30	45138	M10 Nyloc Nut Z/P Optional with Hectaremeter Kit	1
31	47625	M16 Belleville Disc Washer	1
32	45140	M16 Nyloc Nut Z/P	1
33	45151	M16 Light Flat Washer	6
34	45163	M24 H/D Flat Washer Z/P	1

'EcoSeeder' Seed Drill Dual Seedbox Assembly

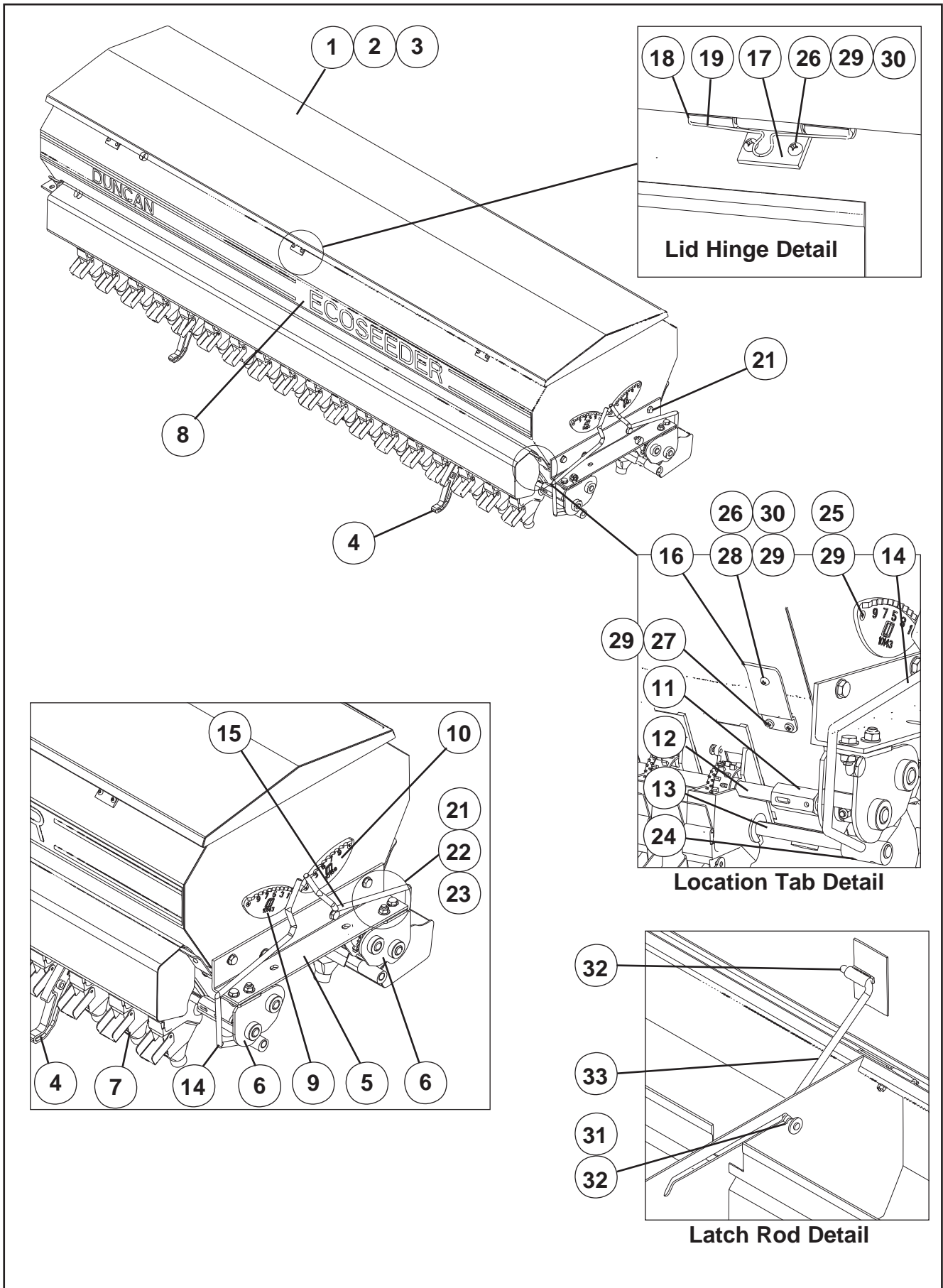

'EcoSeeder' Seed Drill Dual Seedbox Assembly

ITEM	PART No.	DESCRIPTION	QTY
1	61160	Dual Box Assembly 16 Run (with seeder hardware)	1
2	61164	Dual Box With Lid 16 Run (painted sheetmetal -no hardware)	1
1	61162	Dual Box Assembly 18 Run (with seeder hardware)	1
2	61165	Dual Box With Lid 18 Run (painted sheetmetal -no hardware)	1
3	27994	Lid Only	1
4	26599	Calibration Tray Bracket	4
5	27918	Box Set Mounting Bracket	2
6	Refer Page 66	Agitator Drive Assembly	2
7	Refer Page 59	Seeder Assembly	32 36
8	27942	Transfer EcoSeeder	2
9	10143	Box Quadrant Plate	1
10	10158	Box Quadrant Plate Reversed	1
11	22419	Box Shaft Connecting Sleeve	4
12	27914	Box Shaft (20mm)	2
13	27915	Flap Shaft (18mm)	2
14	60096	Front Flapshaft Handle w/assy	1
15	60098	Rear Flapshaft Handle w/assy	1
16	22568	Location Tab (Calibration Tray)	4
17	29163	Hinge Assembly	3
18	22491	Hinge Pin	3
19	27599	Hinge Pin Spring Clip	3
20	43373	Black Edge Trim (4.6m)	1
21	45019S	M12 x 30 Class 8.8 Set Screw Z/P	12
22	45159SS	M12 HD Flat Washer S/Steel Z/P	12
23	45139	M12 Nyloc Nut Z/P	12
24	45186	M10 x 12 Socket Head Grubscrew	4
25	45758	M6 x 16 Countersunk Posidrive Screw Z/P	4
26	45909	M6 x 20 Pan Head Machine Screw Z/P	10
27	45907	M6 x 12 Pan Head Machine Screw Z/P	8
28	45122	M6 Hex Nut Z/P	4
29	45136	M6 Nyloc Nut Z/P	22
30	45150	M6 Light Flat Washer Z/P	6
31	45158	M10 HD Flat Washer Z/P	1
32	45368	M10 Starlock Fixing Washer	2
33	22487	Latch Rod Assembly	1

'EcoSeeder' Seed Drill Single Seedbox Assembly

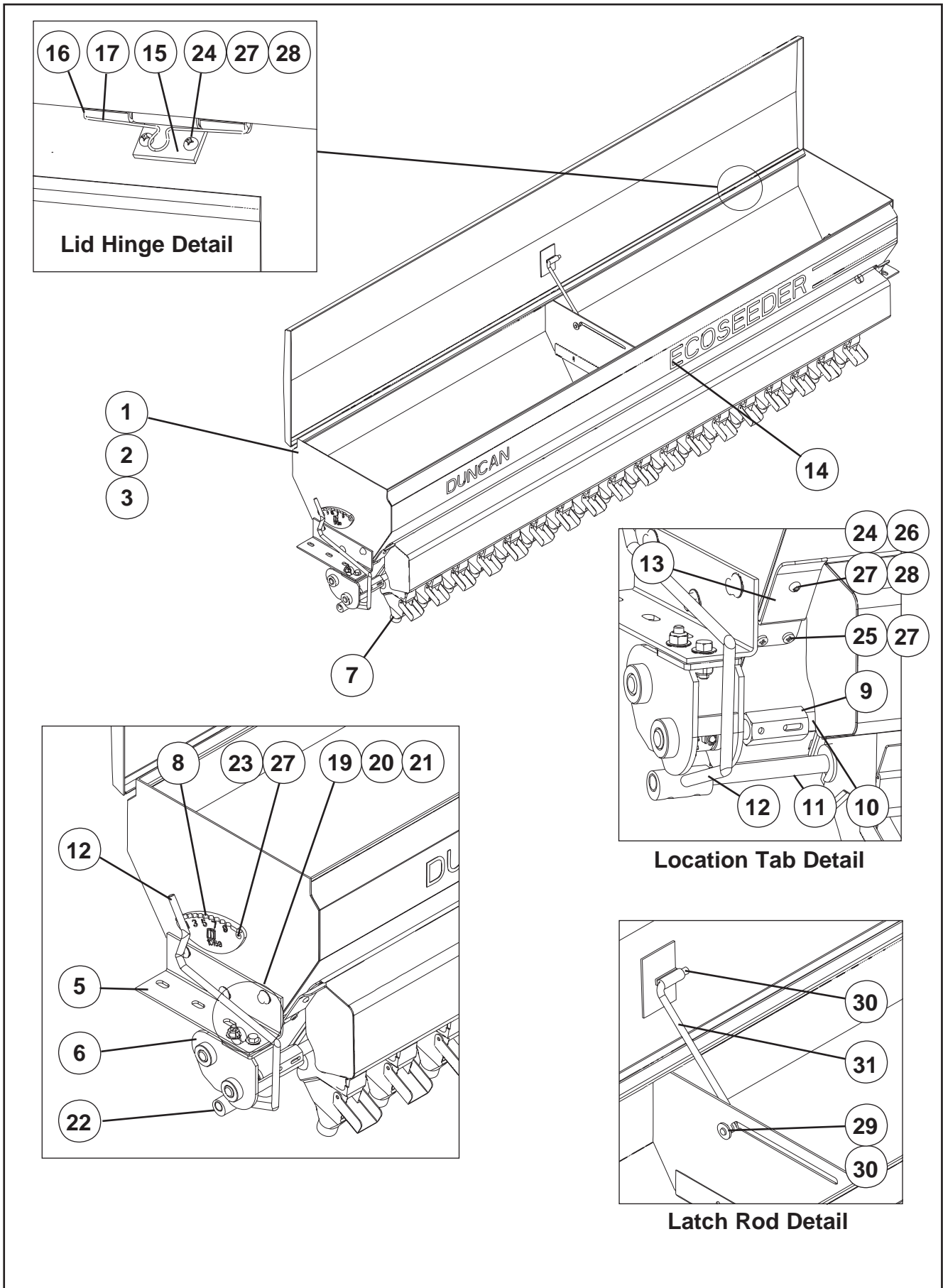

'EcoSeeder' Seed Drill Single Seedbox Assembly

ITEM	PART No.	DESCRIPTION	QTY
1	61184	Single Box Assembly 14 Run (with seeder hardware)	1
1	61186	Single Box Assembly 16 Run (with seeder hardware)	1
1	61188	Single Box Assembly 18 Run (with seeder hardware)	1
2	61190	Single Box With Lid 14 Run (painted sheetmetal - no hardware)	1
2	61191	Single Box With Lid 16 Run (painted sheetmetal - no hardware)	1
2	61192	Single Box With Lid 18 Run (painted sheetmetal - no hardware)	1
3	61210	Lid Only 14 Run	1
3	27930	Lid Only 16 & 18 Run	1
4	26599	Calibration Tray Bracket (not shown)	2
5	27919	Box Set Mounting Bracket	2
6	Refer Page 66	Agitator Drive Assembly 16 & 18 Run (Not 14 Run)	1
7	Refer Page 59	Seeder Assembly	14 16 18
8	10158	Box Quadrant Plate Reversed	1
9	22419	Box Shaft Connecting Sleeve	2
10	61214	Box Shaft (20mm) 14 Run	1
10	27914	Box Shaft (20mm) 16 & 18 Run	1
11	61215	Flap Shaft (18mm) 14 Run	1
11	27915	Flap Shaft (18mm) 16 & 18 Run	1
12	60098	Rear Flapshaft Handle w/assy	1
13	22568	Location Tab (Calibration Tray)	2
14	61241	Transfer EcoSeeder 14Run	2
14	27942	Transfer EcoSeeder 16 & 18 Run	2
15	29163	Hinge Assembly	3
16	22491	Hinge Pin	3
17	27599	Hinge Pin Spring Clip	3
18	43373	Black Edge Trim (2.0m 14 Run 2.3m 16 & 18 Run)	1
19	45019S	M12 x 30 Class 8.8 Set Screw Z/P	6 8 8
20	45159SS	M12 HD Flat Washer S/Steel	6 8 8
21	45139	M12 Nyloc Nut Z/P	6 8 8
22	45186	M10 x 12 Socket Head Grubscrew	2
23	45758	M6 x 16 Countersunk Posidrive Screw Z/P	2
24	45909	M6 x 20 Pan Head Machine Screw Z/P	10
25	45907	M6 x 12 Pan Head Machine Screw Z/P	4
26	45122	M6 Hex Nut Z/P	2
27	45136	M6 Nyloc Nut Z/P	14
28	45150	M6 Light Flat Washer Z/P	6
29	45158	M10 HD Flat Washer Z/P	1
30	45368	M10 Starlock Fixing Washer	2
31	22487	Latch Rod Assembly	1

'EcoSeeder' Seed Drill Agitator Drives

ITEM	PART No.	DESCRIPTION	QTY
1	60110PH	Agitator Drive Rear Housing complete with internals	1
2	60110	Rear Housing only	1
3	60118PH	Agitator Drive Front Housing complete with internals	0 1
4	60118	Front Housing only	0 1
5	22418	21T x 3/8" P Sprocket x 20mm Bore	1 2
6	22422	15T x 3/8" P Sprocket x 20mm Bore	1 2
7	22417	3/8" Pitch BS Chain x 33 Links (Not Shown)	1 2
8	43396	3/8" Pitch Joiner Link (not shown)	1 2
9	44968	M8 x 60 Class 8.8 Bolt Z/P	1 2
10	44965	M8 x 45 Class 8.8 Bolt Z/P	1 2
11	45137	M8 Nyloc Nut Z/P	2 4
12	22425	Agitator Shaft Extension	1 2
13	22426	Seed Shaft Extension	1 2
14	43428	Nylon Bush	3 6
15	22416	Agitator Drive Spacer	1 2
16	22419	Box Shaft Connecting Sleeve	1 2
17	22420	Agitator Shaft Joining Collar	1 2
18	45180SS	M8 x 10 Socket Head Grub Screw S/Steel	2 4
19	44956SS	M6 x 40 Bolt S/Steel	2 4
20	45136SS	M6 Nyloc Nut S/Steel	2 4
21	45150SS	M6 Light Flat Washer S/Steel	2 4

Note: Quantities are per machine single/double box

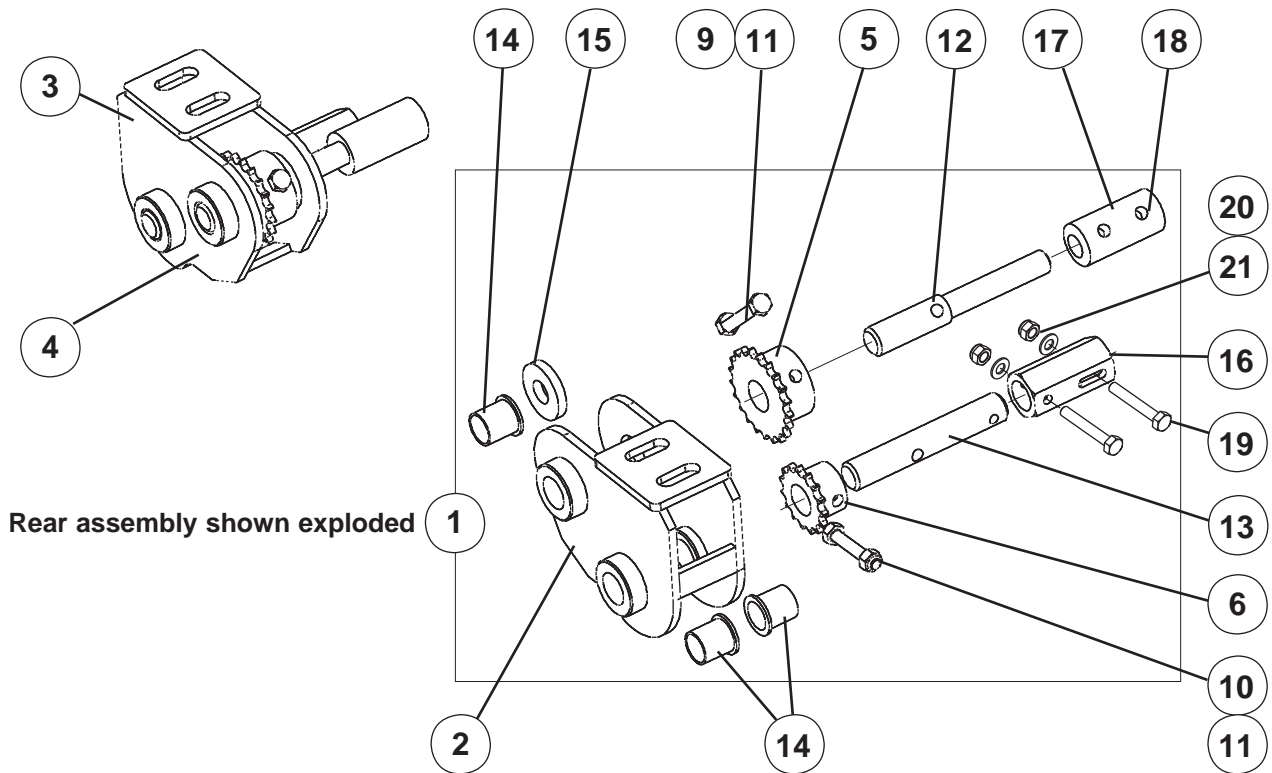

'EcoSeeder' Seed Drill Agitator Shaft Assembly

ITEM	PART No.	DESCRIPTION	QTY
1	61216	Agitator Shaft Assembly 16R	1 2
1	61218	Agitator Shaft Assembly 18R	1 2
2	22420	16mm Agitator Joining Collar	1 2
3	22423	Agitator Shaft Support RH (Short)	1 2
4	22424	Agitator Shaft Support LH (Long)	1 2
5	22428	Agitator Shaft Support Cap	1 2
6	43442	5/8" Lurethane Wiper Seal	2 4
7	45185SS	M10 x 10 Socket Head Grubscrew S/Steel	2 4
8	45410SSS	M8 x 16 Grade 316 Set Screw S/Steel	2 4
9	45137SS	M8 Grade 316 Nyloc Nut S/Steel	2 4
10	47600	M30 ISO Fine Hex Lock Nut Z/P	2 4

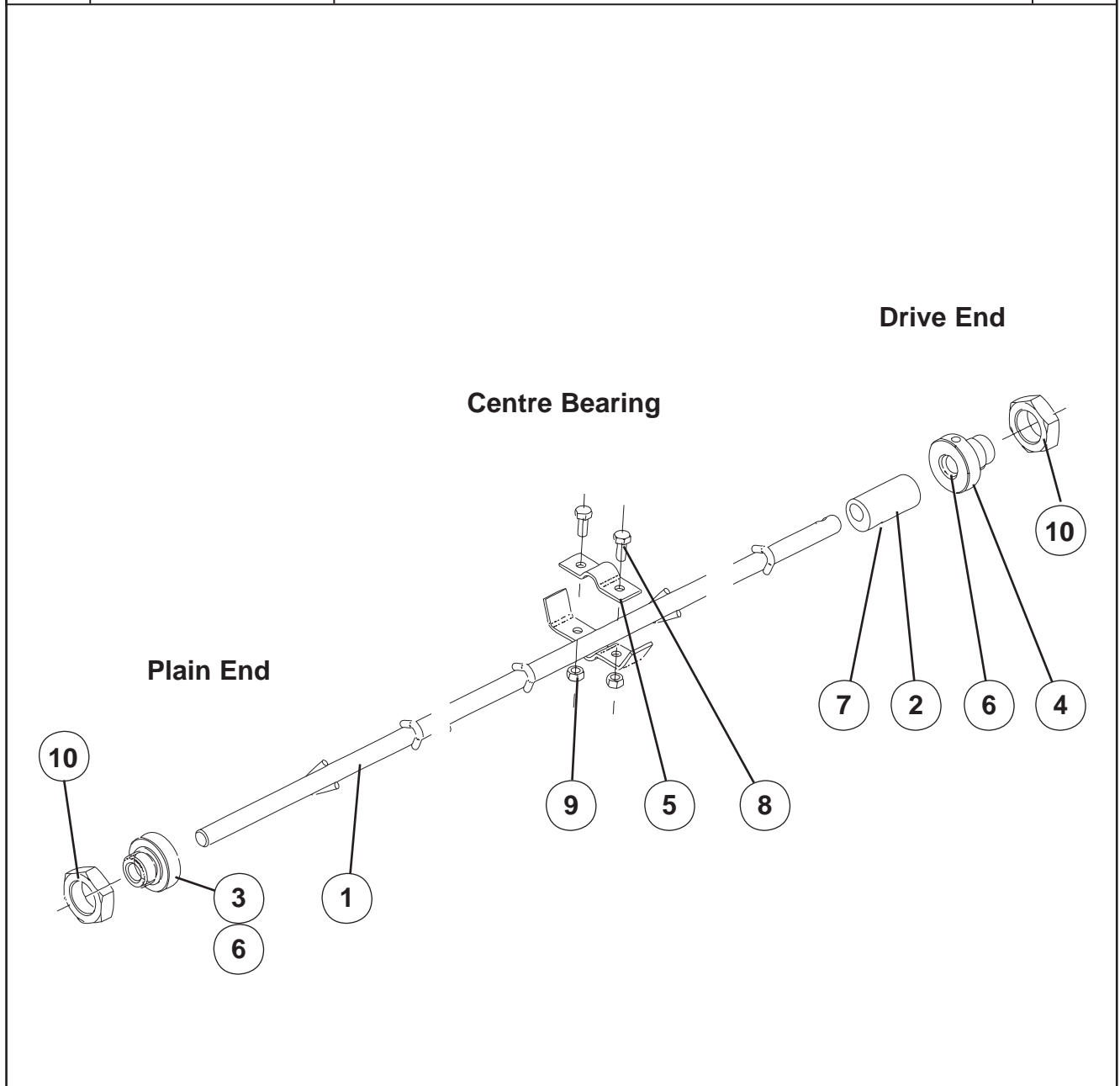

'EcoSeeder' Seed Drill Footboard Arrangement

ITEM	PART No.	DESCRIPTION	QTY
1	61220	Footboard 14 Run	1
1	27982	Footboard 16 & 18 Run	1
2	27978	Footboard Bracket (Single Box)	2
2	27979	Footboard Bracket (Dual Box)	2
3	61155	Footboard Step 14 & 16 Run Single Box 16 & 18 Run Dual Box	1
3	61156	Footboard Step 18 Run (Single Box)	1
4	45051	M16 x 130 Class 8.8 Bolt Z/P	4
5	45038S	M16 x 40 Class 8.8 Bolt Z/P	2
6	45140	M16 Nyloc Nut Z/P	6
7	21690	Clamp Plate (Single Box)	2
8	45020	M12 x 35 Class 8.8 Bolt Z/P	4
9	45139	M12 Nyloc Nut Z/P	4
10	43902	Decal "Slippery When Wet" (Not Shown)	1
11	27893	Harrow Hitch (Optional on Single Box)	2

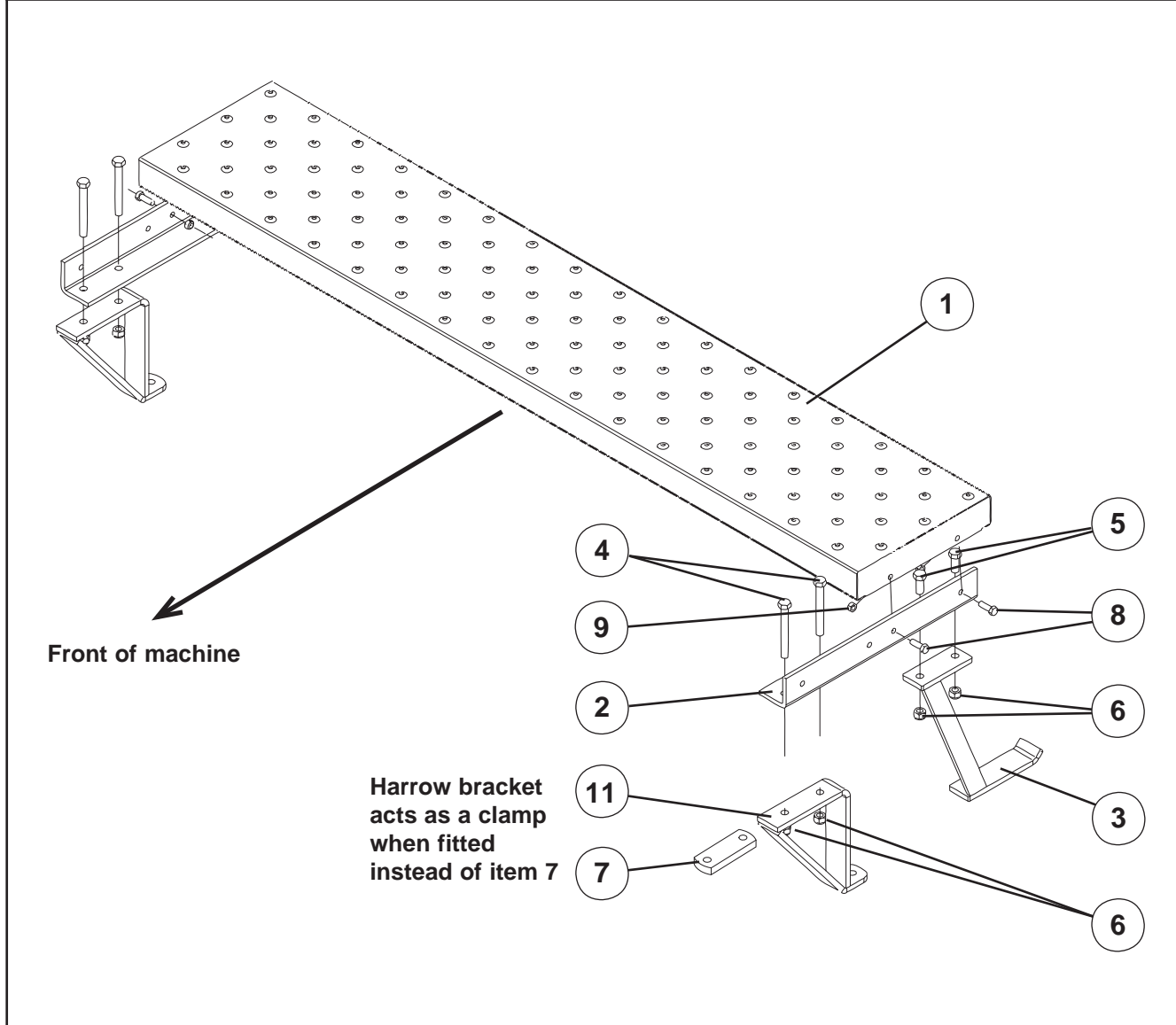

'Renovator' Seed Drill Hectaremeter Kit

ITEM	PART No.	DESCRIPTION	QTY
KIT	44571K	Contains items 1 - 8	
1	44572	Jackal v3 Speed & Area Meter	1
2	44573	Owner's Manual Jackal v3	1
3	43403	Hectaremeter Sensor w/o Nuts AA-110P/5	1
4	43404	Hectaremeter Clamp & Magnet AA-117	1
5	43154	Hectaremeter Sensor Brass Nut	2
6	44028	Window Mount AH-407	1
7	44031	7.5m Cable (2 way) AC-088	1
8	44574	Power Cable Assy Jackal v3 (complete: comprises items 9 - 11 below)	1
9	44029	Power Cable AC-105	1
10	44575	Cable S/Assy Jackal v3 (short 2way)	1
11	44146	11 way Terminal Block P321 Green	1

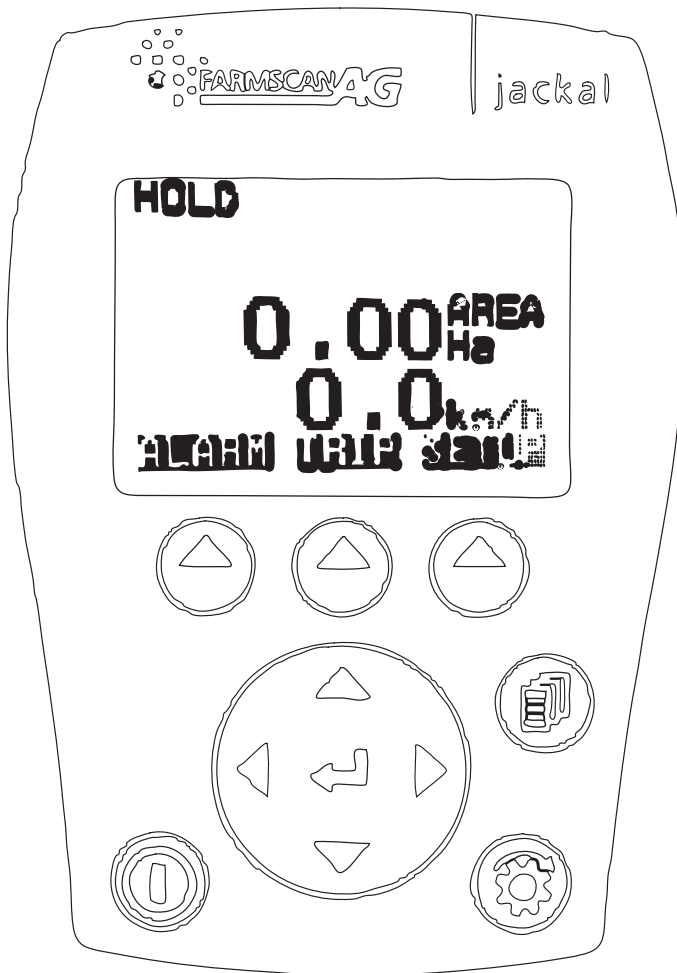

'EcoSeeder' Seed Drill Disc Opener Assy (Option)

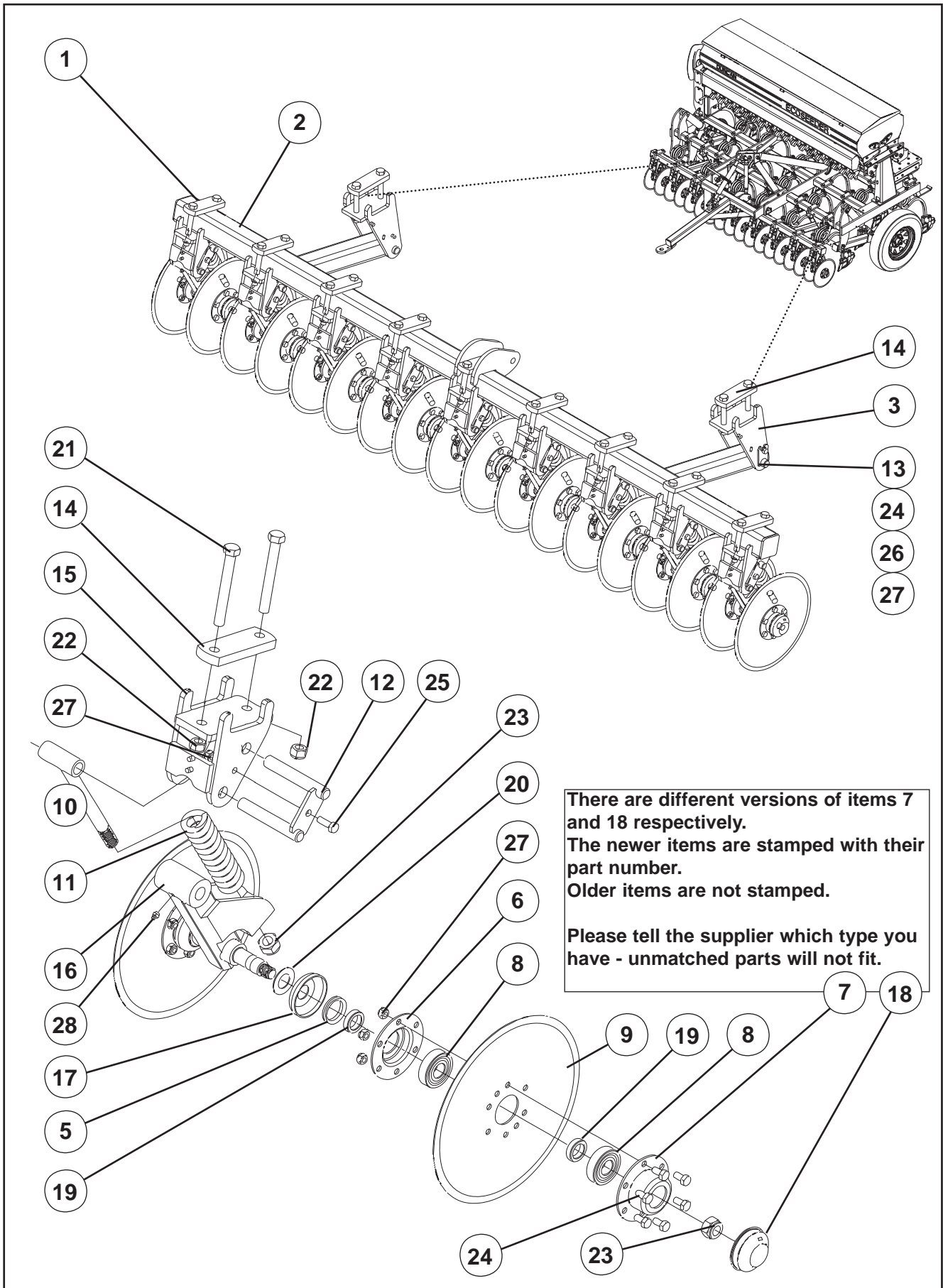

'EcoSeeder' Seed Drill Disc Opener Assy (Option)

ITEM	PART No.	DESCRIPTION	QTY
1	E214WDO	Disc Opener Complete 14 Run	1
1	E216WDO	Disc Opener Complete 16 Run	1
1	E218WDO	Disc Opener Complete 18 Run	1
2	61234	Disc Opener Frame 14 Run	1
2	61232	Disc Opener Frame 16 Run	1
2	61230	Disc Opener Frame 18 Run	1
3	25562	Disc Opener Frame Support	2
4	43053	Top Link 20.5 x 28.5 x 3/4 Dia (Not Shown)	1
5	43352	Seal	14 16 18
6	17537	Bearing Housing	14 16 18
7	18364	Bearing Housing	14 16 18
8	11351	Bearing	28 32 36
9	11353	Plain Disc 12-1/2" Dia.	14 16 18
10	21268	T Bolt Assembly	7 8 9
11	21265	Disc Opener Spring	7 8 9
12	21279	Double Pivot Pin Assembly	7 8 9
13	21245	Attachment Arm Pivot	2
14	21690	Clamp Plate	9 10 11
15	60460	Disc Mounting Bracket	7 8 9
16	27606	Double Axle Arm Assembly	7 8 9
17	22080	Dust Cap	14 16 18
18	11361	Hub Cap	14 16 18
19	22078	Seal Collar	28 32 36
20	47461	1" Light Flat Washer Z/P	14 16 18
21	45051	M16 x 130 Class 8.8 Bolt Z/P	18 20 22
22	45140	M16 Nyloc Nut Z/P	18 20 22
23	45141	M20 Nyloc Nut Z/P	21 24 27
24	45001S	M10 x 20 Class 8.8 Set Screw Z/P	86 98 110
25	45003	M10 x 30 Class 8.8 Set Screw Z/P	7 8 9
26	45166	M10 Spring Washer Z/P	2
27	45138	M10 Nyloc Nut Z/P	91 103 115
28	43118	Grease Nipple Straight	9 10 11
29	47154	3/4" UNF x 4-1/2" HT Bolt Z/P (Not Shown for Top Link)	1
30	47155	3/4" UNF x 5" HT Bolt Z/P (Not Shown for Top Link)	1
31	47546	3/4" UNF Nyloc Nut Z/P (Not Shown for Top Link)	2

'EcoSeeder' Seed Drill 3PTL to Trailing conversion

Kit 27975K

Remove the turnbuckles from the wheel legs.

Use one turnbuckle on the drawbar.

Fit the hydraulic rams onto the wheel legs.

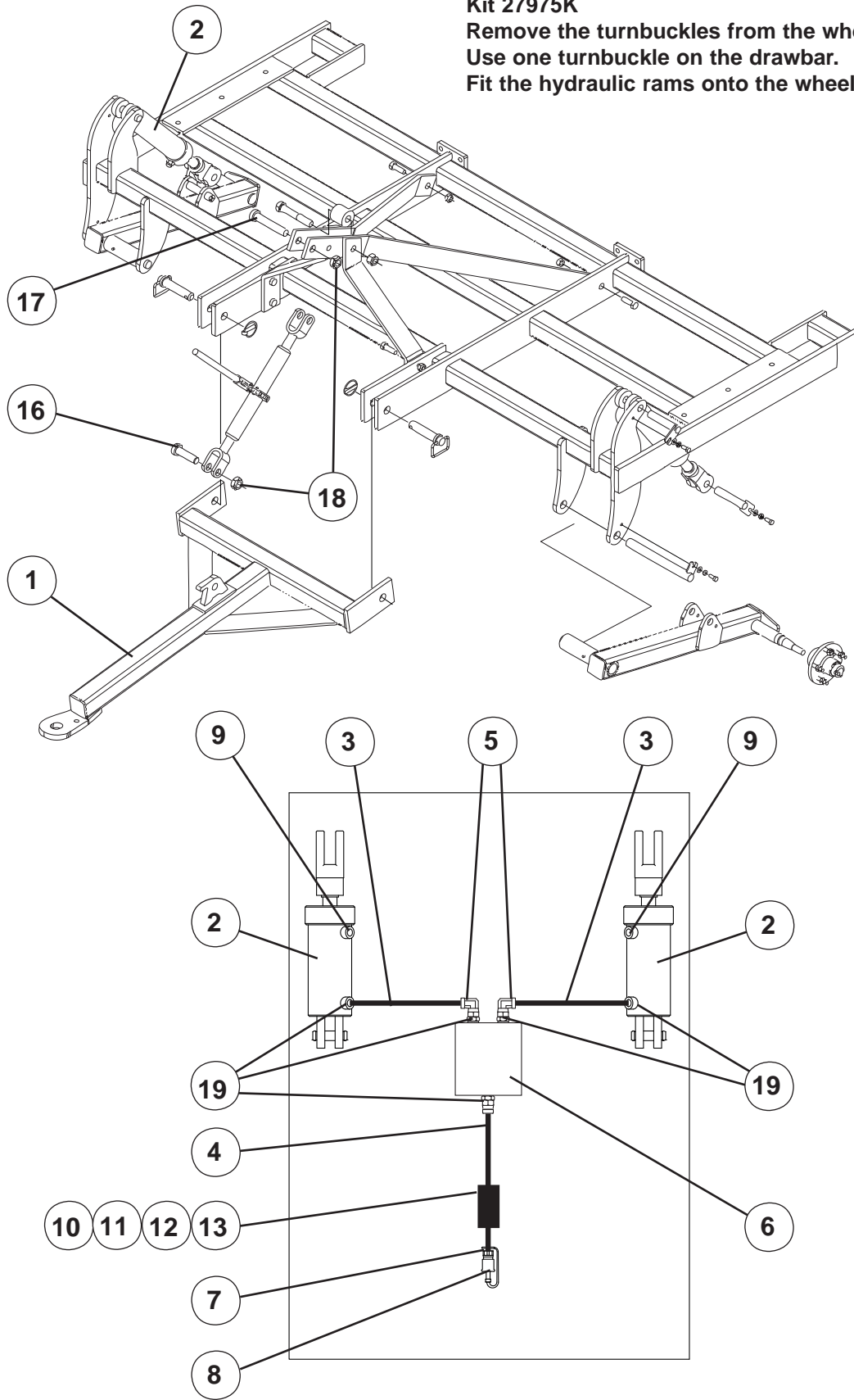

'EcoSeeder' Seed Drill 3PTL to Trailing conversion

ITEM	PART No.	DESCRIPTION	QTY
1	27960	Drawbar Assembly	1
2	43977	2.5 x 8 x 1.5 Hydraulic Ram	2
3	27970	Hydraulic Hose 1.32m Long	2
4	27971	Hydraulic Hose 2.52m Long	1
5	43338	3/8" BSPTM 3/8" BSPF Swivel 90° Elbow	2
6	61258	Hydraulic Block Assembly	1
7	43147	1/2" Male Probe QR Coupling	1
8	43617	1/2" Dust Cover	1
9	43152	3/4" UN 'O' to 3/8" BSP Silencer	2
10	43391	3/8" Dowty Washer	2
11	43392	3/8" BSP MM Nipple	1
12	43393	Ball Valve	1
13	43445	1/2" BSPT to 3/8" BSPP Nipple	1
14	43499	Whoa Stop Collar Set (Not Shown)	2
15	43333	Plastic Tie Strap (Not Shown)	7
16	47251	1" UNF x 3-1/2" HT Bolt Z/P	1
17	47254	1" UNF x 5" HT Bolt Z/P	1
18	47552	1" UNF Nyloc Nut Z/P	2
19	43280	3/4" UN 'O' to 3/8" BSP Nipple	5

'EcoSeeder' Tine Harrow (Optional)

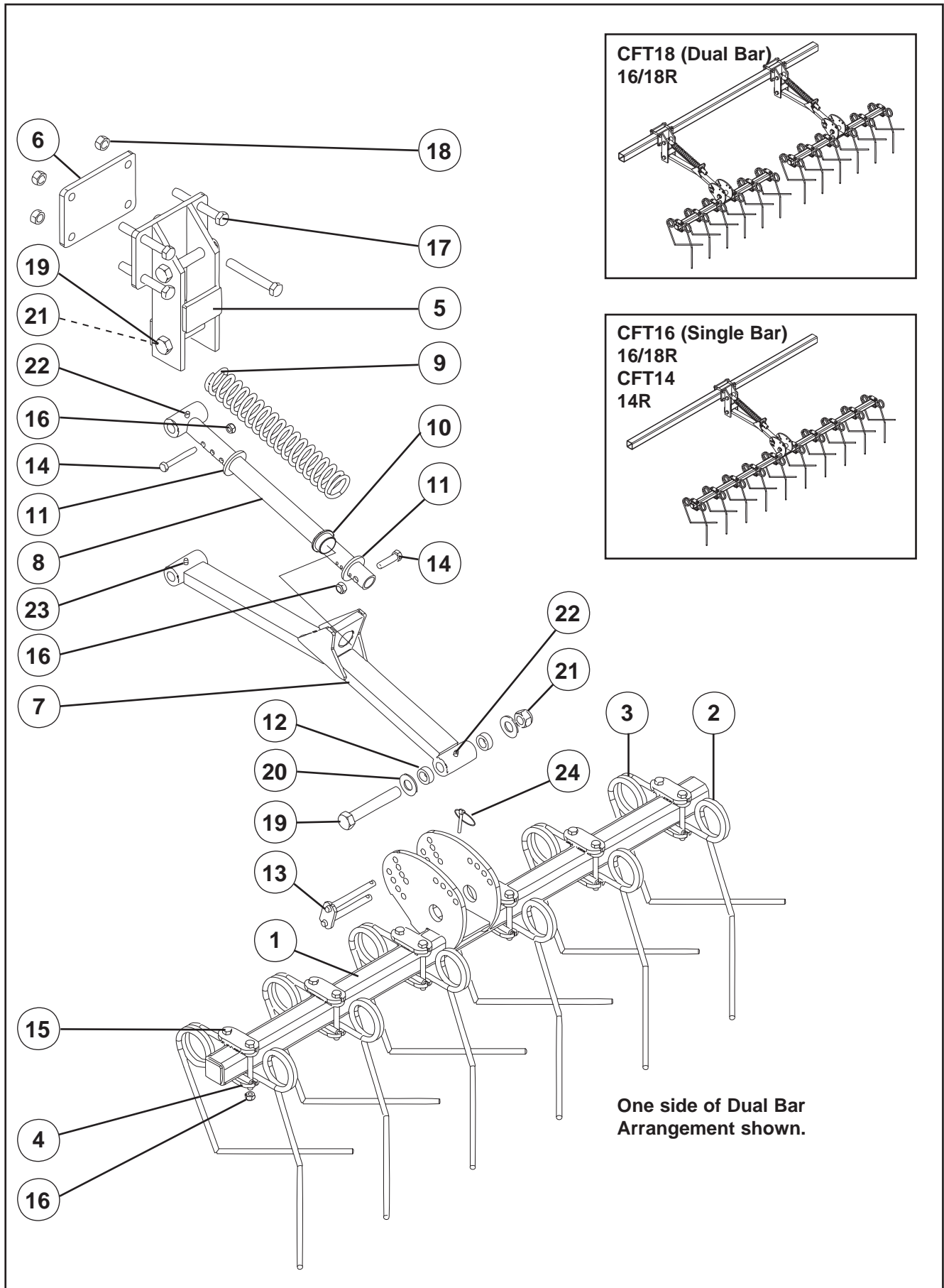

‘EcoSeeder’ Tine Harrow (Optional)

ITEM	PART No.	DESCRIPTION	QTY
1	61225	Tine Harrow 14 Run Bar	1 0 0
1	61224	Tine Harrow Dual Bar	0 2 or 2
1	60425	Tine Harrow Single Bar	0 1 or 1
2	60255	LH Tine	8 10 12
3	60256	RH Tine	8 10 12
4	60422P	Tine Harrow Tine Bracket	16 20 24
5	60426	Tine Harrow Strut	1 1 2
6	60428	Strut Bolt Plate	1 1 2
7	60430	Swinging Arm Assembly	1 1 2
8	60435	Guiding Bar Assembly	1 1 2
9	60437	Tine Harrow Spring	1 1 2
10	60438	Guiding Bar Bush	1 1 2
11	60439	Guiding Spacer	2 2 4
12	60440	Swinging Bracket Spacer	2 2 4
13	60441	Tine Harrow Pivot Pin	1 1 2
14	45006	M10 x 45 Class 8.8 Bolt Z/P	2 2 4
15	45016	M10 x 100 Class 8.8 Bolt Z/P	16 20 24
16	45138	M10 Nyloc Nut Z/P	18 22 28
17	45050	M16 x 120 Class 8.8 Bolt Z/P	4 4 8
18	45140	M16 Nyloc Nut Z/P	4 4 8
19	45073	M20 x 130 Class 8.8 Bolt Z/P	3 3 6
20	45161	M20 HD Flat Washer Z/P	2 2 4
21	45141	M20 Nyloc Nut Z/P	3 3 6
22	43118	M8 Grease Nipple Straight	2 2 4
23	43120	M8 Grease Nipple 90°	1 1 2
24	43675	1/4" x 1-1/2" Linch Pin	1 1 2

'EcoSeeder' Uni-Roller (Optional)

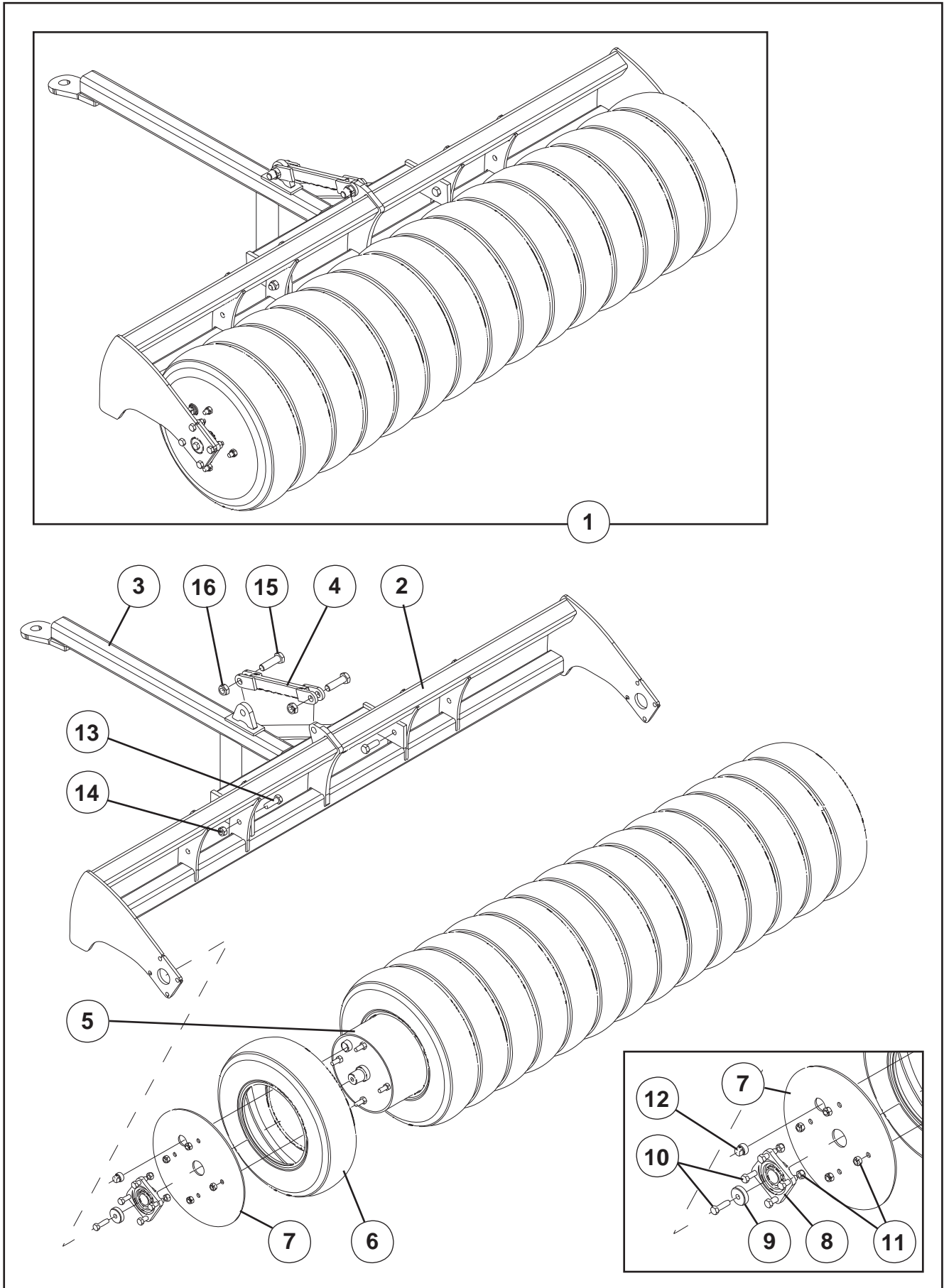

‘EcoSeeder’ Uni-Roller (Optional)

ITEM	PART No.	DESCRIPTION	QTY
1	RTR24	Uni-Roller Complete	1
2	60504	Roller Frame W/Assy	1
3	60490	Drawbar Assembly Complete	1
4	60496	Link	1
5	60502	Roller Tube W/Assy	1
6	43589	Tyre 185/70 R13	15
7	60494	End Retaining Plate	2
8	43588	Bearing Unit	2
9	60495	Roller Axle Retainer	2
10	45041	M16 x 55 Class 8.8 Z/P Bolt	10
11	45140	M16 Nyloc Nut	16
12	43271	Drain plug	2
13	45064	M20 x 65 Class 8.8 Z/P Bolt	2
14	45141	M20 Nyloc Nut	2
15	47251	Bolt 1"UNF x 3.5" HT	2
16	47552	Nut 1" UNF Nyloc	2

'EcoSeeder' Tow Hitch/Baffle Extensions (Optional)

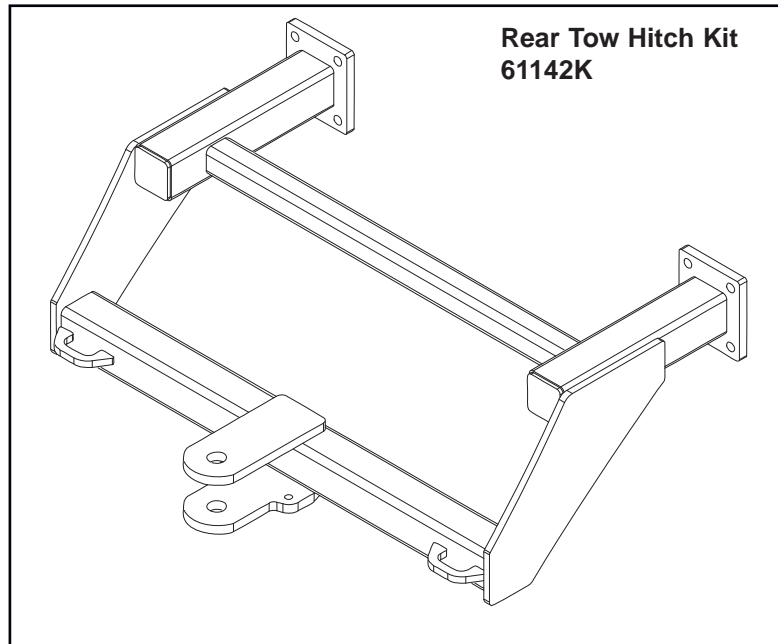

All kits are supplied complete with the required fasteners

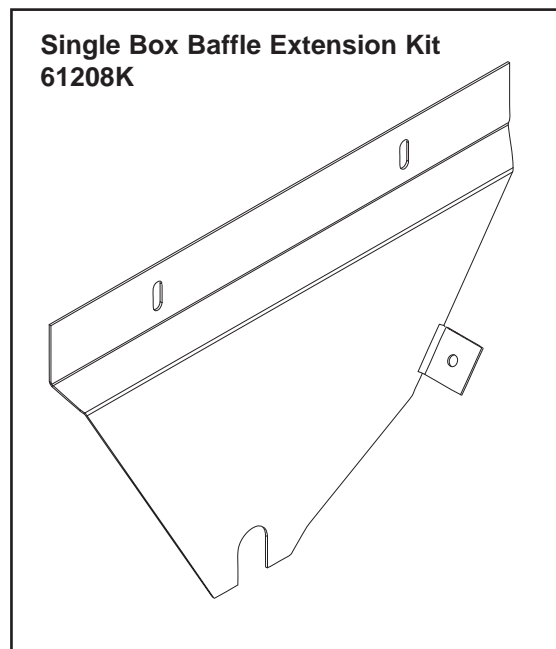
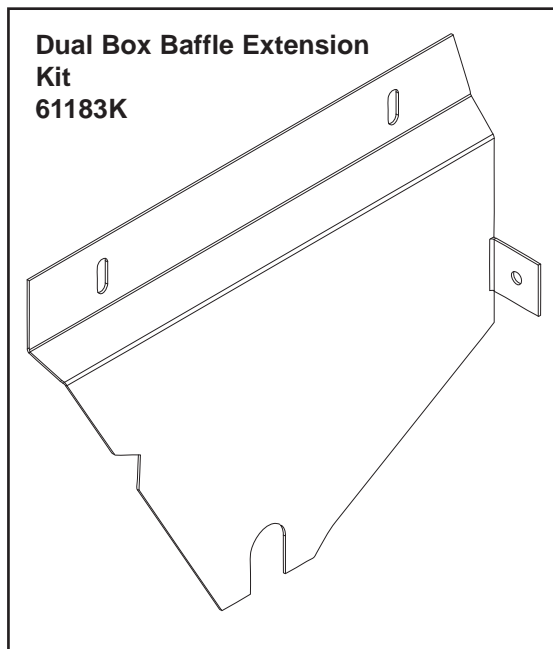



CEproof.

CEproof International Limited
Hillside House
Lester Way
Wellingford
Derbyshire G47D 6TA
UNITED KINGDOM

EC DECLARATION OF CONFORMITY

Description of Machine: Agricultural Seed Drill Machine
Make / Model: Eco Seeder
Type: Single / Dual Box – 14 / 16 / 18 R Disc Opener
Production Run Numbers: 000001 to 100000
Serial Numbers: EME16W
EME16W / EMA16W / ETE16W / ETA16W
EME18W / EMA18W / ETA18W
Options fitted: E214WDO / E216WDO / E218WDO
CFT14 / CFT16 / CFT18
Name of Manufacturer: CLOUGH AGRICULTURE LTD
Address: 100 Hilton Highway
Washdyke
Timaru 7810
New Zealand

We hereby declare that the product described above complies with the relevant provisions of the appropriate EC Directives and Harmonised Standards of the European Union listed below and accordingly carries CE-marking.

Machinery Directive 2006/42/EC

The following Standards are applicable:

- EN 204 : 1992
- BS EN 942: 1996
- BS 1841-1:1996 / ISO 730-1: 1994
- BS 5400-1: 2002
- EN ISO 12100-2:2003

Date of Declaration: 16th February 2010

Date of Issue: 16th February 2010



Craig McEneaney

Managing Director
Clough Agriculture Ltd



Alasdair Reay

CEproof Directives Ltd
Keeper of technical documentation
in the European Union

