



 **KRONE**
THE POWER OF GREEN

Swadro

Rotary rakes with Lift Tines



www.krone.de

Swadro

Side- and centre delivery rakes
with Lift Tines
Innovative KRONE solutions for
all applications

i

- KRONE Lift Tines rake up faster, produce more accurate windrows and deliver cleaner forage
- Jet Effect rotors protect the ground during headland turns for consistently clean forage
- High ground clearance during headland turns
- Maintenance-free rotors and rotor gearboxes
- Hard-wearing DuraMax cam tracks with three-year warranty
- Very compact transport position









Swadro model versions	4
The Swadro rotor	6
- Cardanic suspension and Jet effect	8
- Tridem chassis	10
- Tine arms	12
- Lift Tines	14
Three-point hitch single-rotor rakes	
Swadro 35, 38, 42 and 46	16
Trailed single-rotor rakes	
Swadro 38T, 42T, 46T	20
Trailed twin-rotor side delivery rake the flexible	
Swadro 710/26T	22
Trailed twin-rotor side delivery rakes	
Swadro TS and TS Twin	26
Trailed triple-rotor side delivery rake	
Swadro 1010	32
Trailed twin-rotor centre delivery rakes	
Swadro TC and TC Plus	34
Trailed four-rotor centre delivery rakes	
Swadro 1400 and 1400 Plus	40
Trailed six-rotor centre delivery rake	
Swadro 2000	48
Technical Data	56



All Swadro models at a glance

All Swadro models offer a high-quality build that is able to cope with the most arduous conditions and applications. Innovative and practical, these KRONE machines provide a superior quality of work and unique longevity. Swiftly and efficiently, they tailor the windrows to the following harvester and deliver a clean and loss-free rake in the most difficult conditions.

 <p><i>Mounted single-rotor model</i> 3.50 m - 4.60 m (11'6" - 15'1") work widths</p>	 <p><i>Trailed single-rotor model</i> 3.80 m - 4.60 m (12'6" - 15'1") work widths</p>	 <p><i>Twin-rotor side delivery model</i> Swadro 710/26T 6.20 m (20'4") or 2x3.40 m (2x11'2")</p>
 <p><i>Twin-rotor side delivery model</i> Swadro TS and TS Twin 6.20 m - 8.20 m (20'4" - 26'11") work widths</p>		 <p><i>Twin-rotor side delivery model</i> Swadro 1010 9.70 m (31'10") work width</p>
 <p><i>Twin-rotor centre delivery models</i> Swadro TC and TC Plus Variable 5.70 m - 10.00 m (18'8" - 32'10") work widths</p>	 <p><i>Four-rotor centre delivery models</i> Swadro 1400 and 1400 Plus Variable 11.00 m - 13.50 m (36'1" - 44'3.5") work widths</p>	 <p><i>Six-rotor centre delivery model</i> Swadro 2000 Variable 11.00 m - 19.00 m (36'1" - 62'4") work widths</p>

The Swadro rotor

Heavy-duty and maintenance-free

- Maintenance-free rotors and rotor gearboxes
- Hard-wearing DuraMax cam tracks with a three-year warranty
- Rotors featuring the KRONE Jet Effect to avoid crop contamination on headlands



Permanently lubricated and maintenance-free

The enclosed bevel gearboxes and the tine arm rollers are permanently lubricated for optimum care and attention. So, operators need not bother to lube a single component on the rotor.

Sturdy bearing housings

The housings are made from light and robust cast aluminium and the bearings are spaced wide apart offering highest stability in heavy crop. The permanently lubricated groove ball bearings are maintenance-free.

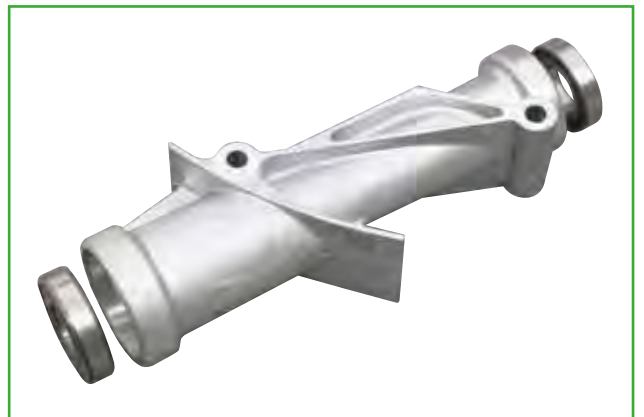

The advantages

The Swadro rotor scores on excellent quality of work in very difficult crop, great stability, hard-wearing components and no maintenance at all. These advantages are gained from a permanently lubricated driveline, the DuraMax cam tracks, the centrally suspended rotors in a trailing set-up, the cardanic system, the KRONE Jet Effect, the Tridem running gear as well as the new Lift Tines.

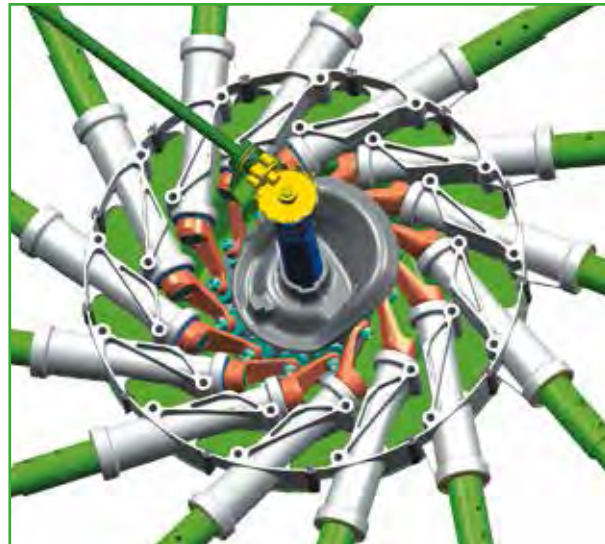

Steep cam tracks

As the rollers move in steep cam tracks they lift and lower the tine arms quickly and with greatest precision to the effect that the crop stays clean and the windrows are tidy and boxy. The 47 mm (2") diameter tine guiding rollers offer a generous contact area, are protected from ingress of dust and absolutely maintenance-free.



Hard-wearing KRONE DuraMax cam tracks

For greatest longevity, these cam tracks are made from high-tensile and Bainite-tempered cast SG iron which offers exceptional resistance to wear and tear and is absolutely maintenance-free. For this reason, KRONE grants a three-year warranty for the DuraMax cam tracks.



The Swadro rotor

Great flexibility and cleanest rakes

- Optimum contouring in any direction through pivoting rotors
- Cleanest forage from the KRONE Jet Effect during take-off and touch-down
- Central suspension for a uniform ground pressure across the full widths of the rotors



The cardanic rotor suspension

The rotors pivot in and across the direction of travel to give optimum adaptation to undulating ground. A cardanic joint on the arm with two elongated holes prevents the tines from being pressed into the ground or from being left suspended in the air, thereby avoiding crop contamination as well as throwing the grass about.

The elongated holes

The elongated hole at the top allows the rotor to pivot across the direction of travel whereas the elongated hole at the bottom allows pivoting in direction of travel.

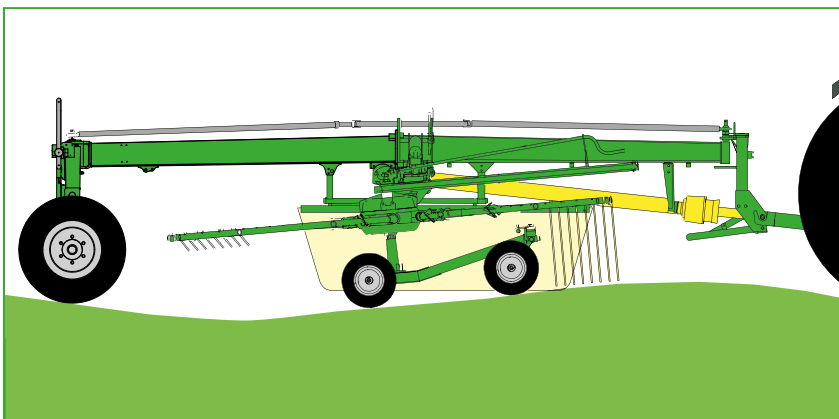

The cardanic system and the KRONE Jet Effect

Taking off/touching down like a jet the KRONE Jet Effect prevents the tines from damaging the sward on the headland and ensures the crop stays clean. As the bogies are lowered into work, the rear wheels touch down first before the leading wheels follow. Vice versa, as the rotors lift out it is the leading wheels that lift out first and the rear wheels that follow. This is identical with the take-off and touch-down phases observed with airplanes.



The trailing rotors

The rotors are trailed rather than being pushed in direction of travel. Therefore they enjoy greater flexibility in following ground contours and there is no risk of tines being pressed into the soil



The central suspension

The rotors suspend centrally across the direction of travel which allows them to produce consistent and high-quality windrows. The special suspension ensures they always stay level as they lift and lower on the headland. In addition, the machine's weight is distributed uniformly on all wheels of the running gear as it travels down the field.

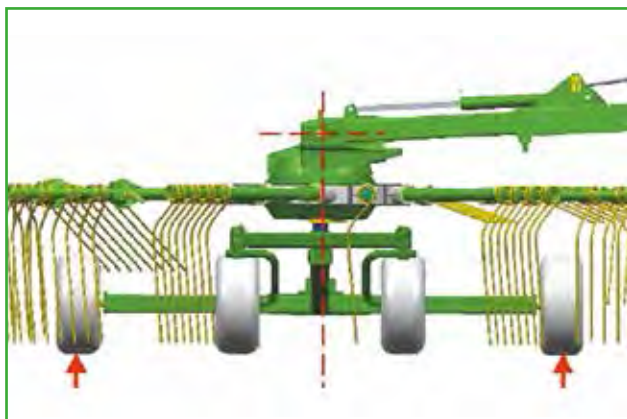

The Swadro rotor

Great stability and excellent tracking

- Cleanest rakes as the bogie wheels run in vicinity of the tines
- Straightforward angle adjustment
- Castering wheels are standard at the front and an option at the rear to protect the sward



Contouring front axle

The leading caster wheels give excellent tracking in turns and curves. A track rod links the wheels for quiet running and the pivoting suspension provides for plenty of axle travel to absorb ground undulations.



Wide track width and quiet running

It is the extra wide tracking width of the running gear that absorbs the forces that are generated by the rotors and keeps them level and stable in undulating terrain.



The KRONE Tridem running gear

All rotors run on a KRONE developed Tridem running gear as standard.

The running gear consists of an extra wide rear axle and a flexible front axle which form a triangle.

Occupying all space under the rotor, the construction has the wheels stabilise the rotors exactly in those areas where the tines work under load.

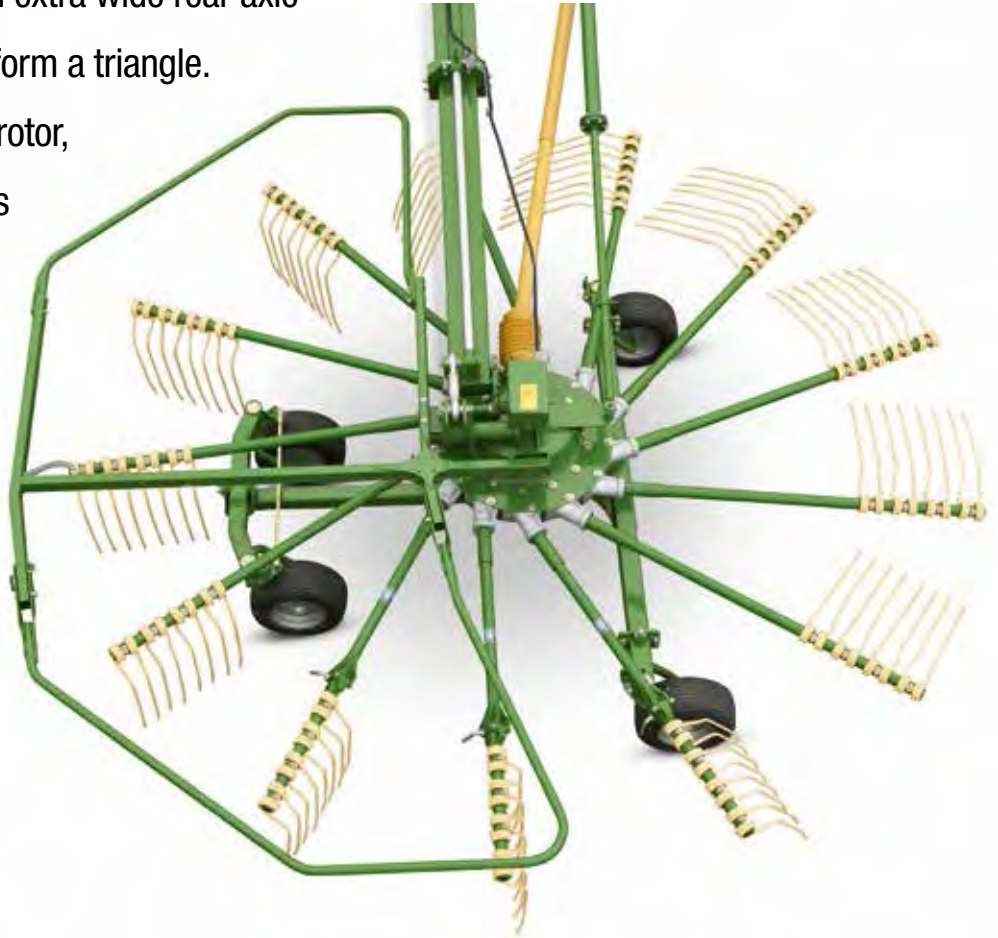

Adjusting the side angle

A pin setting system on the Tridem rear wheels sets the rotor tilt across the direction of travel steplessly to adjust to current yields.



The castering wheels

The rear axles also take castering wheels as an option. These give better tracking in curves, eliminate scuffing and are gentle on the running gear as well as on the sward.



The Tandem running gear

A Tandem running gear is available for the rear axle where it enhances rotor control.



The Swadro rotor

Stable running and tidy windrowing

- Large-diameter and thick-walled tine arms ensure absolutely dependable operation
- Easy and fast tine arm attachment and removal
- Sturdy foldback mechanism



Tine arms and tines

The tine arms are thick-walled and large in diameter. 10.5 mm (0.4") double tines that wind around the arms in three

massive spring coils offering outstanding flexibility and longevity. Each tine arm carries four double tines.

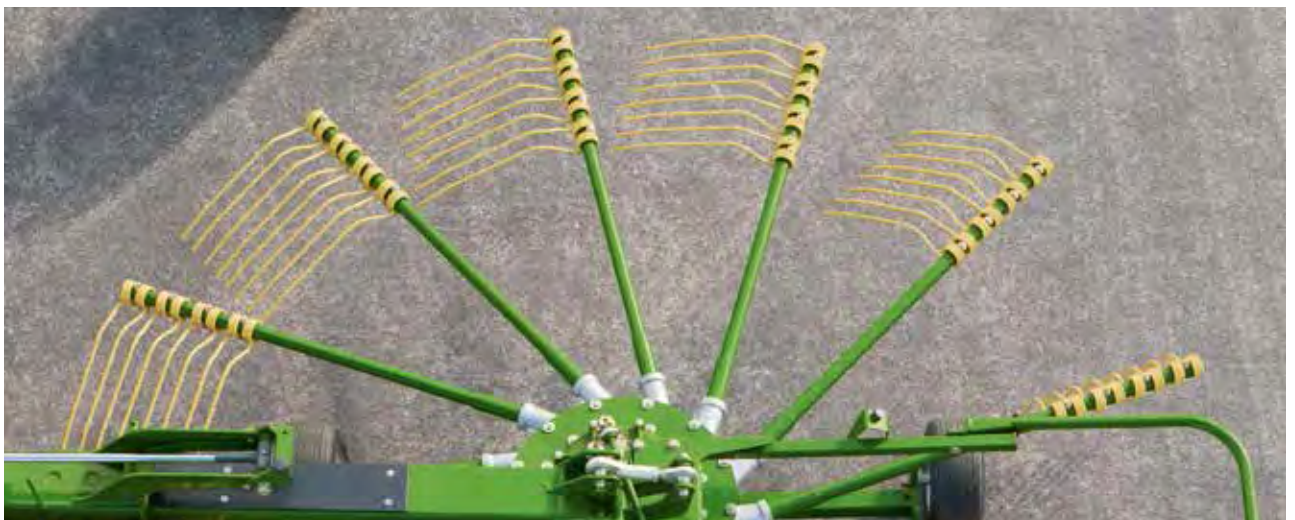

Functional and user-friendly

Maximum strength and stability, easy handling and reliable functionality are the trademark features of the KRONE Swadro tine arms.

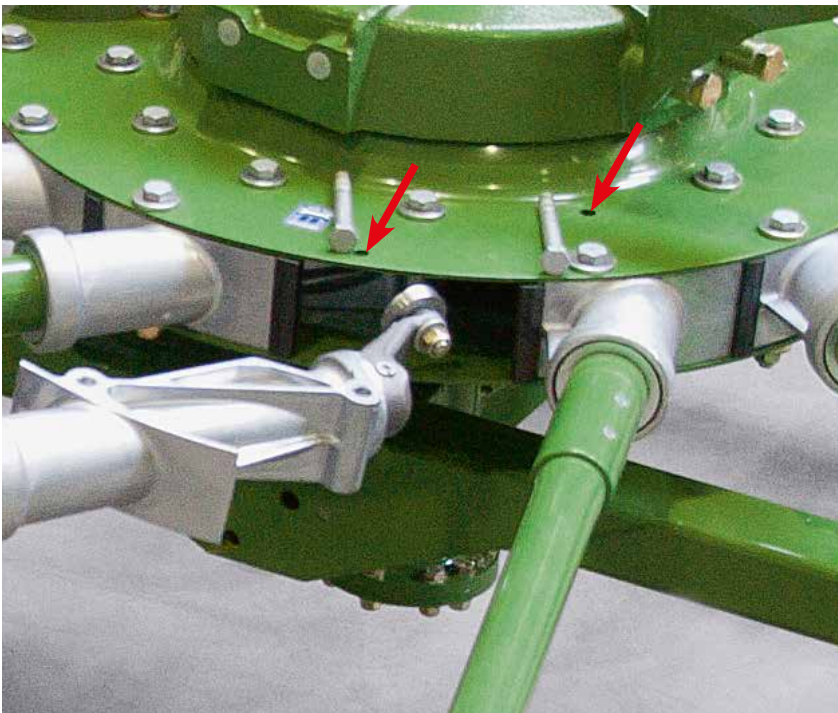

Each tine arm is easily removed
Simply undo two bolts to remove the entire arm complete with bearing and roller.



Folding tine arms

Most Swadro models can be specified with foldable tine arms that reduce the machine's storage and transport height clearly below 4 m (13'2").



Sturdy foldback mechanism

Gap-free and hard-wearing functionality comes from a holder that is made from hardened steel and has a pivoting joint that is loaded by a Belleville spring on the models with multiple rotors.



The Lift Tine

Clean windrows, better feed

- Greater ground clearance
- Higher work rates
- No crop contamination
- Higher-quality forage
- Minimum crop loss



No crop contamination

Thanks to their excellent performance, the Lift tines can work at a greater ground clearance than traditional tines. And thus reduce the risk of crop contamination as well as tine wear.

Better and faster – courtesy of KRONE Lift Tines



All rakes in this brochure are specified with the new Lift Tines. The specialty about these tines is the fact that they are angled in two different positions. This optimized design brings special advantages which have been explored in field trials by KRONE and verified by a DLG test.

The DLG Focus Test shows that KRONE Lift Tines boost productivity.

A comparison of these tines and traditional tines shows

- They rake up more material per hectare at typical work rates and with tines in typical settings and cut common loss rates by 50%
- They deliver clearly higher work rates without compromising on the quality of work and increase the overall output by up to 27%
- They give more effective rakes and protect the sward at an up to 1 cm (3'3") higher ground clearance
- They lead to better quality forage, as their Lift effect and higher ground clearance minimize contamination

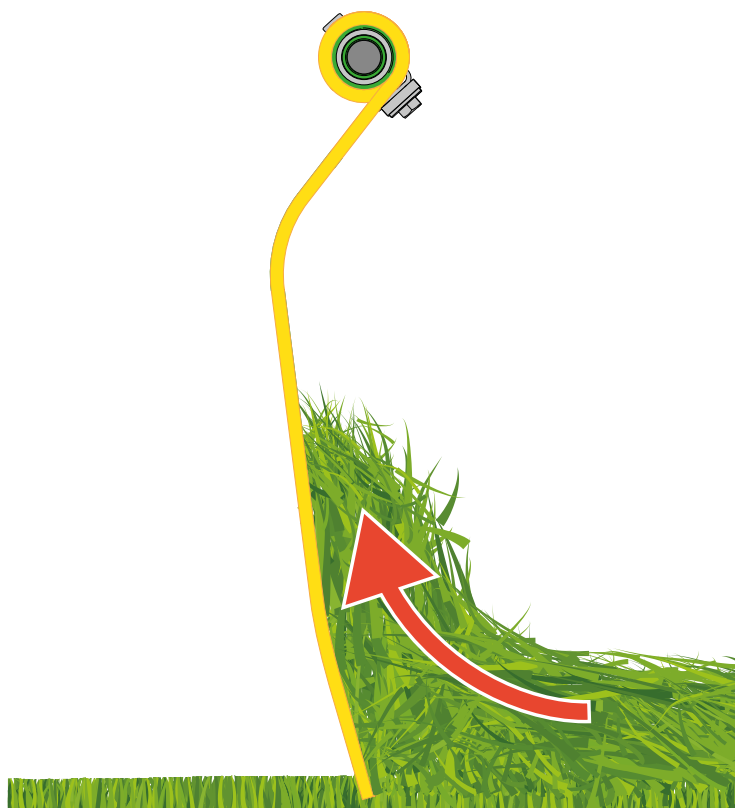

Setting the tines to an optimum position

The special Lift Tines perform better, because their ends maintain a steep angle even in heavy crop and lift it more easily, which leads to more uniform windrows. As a result, the machine can work at a faster pace and still deliver consistently well shaped windrows.

Swadro 35, 38, 42, 46

Three-point hitch single-rotor rakes

- Standard tandem axle and flotation tyres
- Stepless work width control for a consistently high-quality forage
- The jockey wheel in the middle guides the rotor in undulating fields



Big boots

Fitted with Super Balloon 16/6.50-8-ply tyres, these Swadro single-rotor rakes simply got what it takes. These tyres offer superior rides and light treading for best protection of the sward.



The contouring rotor

The Swadro single-rotor rakes have a tandem axle as standard specification with wheels running closely alongside the tines – a set-up that warrants perfect contouring and cleanest rakes in undulating terrain.



Absolutely clean

No haulm is left behind - not even in heavy material. A pin/hole setting system on either side of the rotor adjusts the tilt.



Great stability from a wide chassis with tandem axle

The three-point hitch single-rotor Swadro models of 3.50 m to 4.60 m work widths (11'6" to 15'1") stand out for their unique strength and engineering. Many of their well-proven features were taken over from the high-output rakes. The larger the rotor diameter the more important the running gear. It is down to the running gear whether the tines cover the full work width and work at a consistent height.



These are essential parameters for clean forage, because undulations and ruts can lead to contaminated and thus poor-quality forage. For this reason, KRONE offers the single-rotor rake with a tandem axle and makes this a standard feature. This can be upgraded by a leading land wheel that is provided as an option for even better contouring.

Perfect control

The rakes are available with a height-adjustable and caster-steer land wheel as optional specification that enhances the rotor's contouring in rough terrain.



Perfect guidance

A selection of holes for the top link ensures optimum rotor control in all conditions. Attaching the top link in the elongated hole allows the use of a leading land wheel.



Convenient adjustment

The rotor depth is controlled steplessly from a crank that is operated from the tractor seat – a quick and easy system that warrants clean and loss-free rakes.



Nimble field work

Safe road travel

- Damping rods feature internal compression springs
- Auto-centering lift-out system
- Folding tine arms



Tailoring windrows to harvesters

Adjusting the crop deflector is as easy as it can get. Simply telescope the unit in and out as necessary.

Unique design

The patented tracking system steers the KRONE rakes through the tightest turns. Combining a swing arm with damping rods leads to a steering angle of about 20° which in turn translates into excellent manoeuvrability and a high lift-out.

Dampers improve the ride

The damping rods ensure the machine casters dependably at speed and when working downhill.

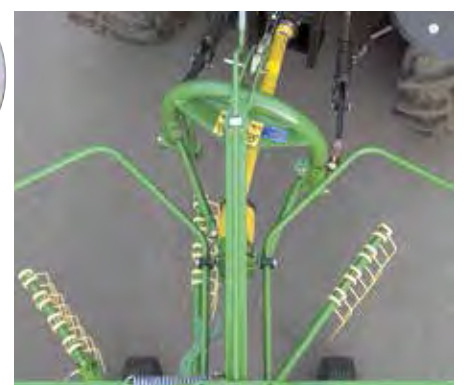

Safe road travel

Dense traffic and a fast tractor present a challenge to the attached machine and its road safety, a challenge that KRONE rakes meet easily. Once the tine arms are folded and the crop deflector is raised a Swadro single-rotor rake makes an extremely compact combination for swift travel between fields.



Wide in the field and narrow on the road

Folding the outer tine arms into transport position is a quick and straightforward operation, which requires only little effort.

Convenient and automatic

As the machine is raised into transport position, the damping rods maintain the machine centrally behind the three-point headstock. No manual locking required.

Convenient

A massive tension spring helps raising the windrow deflector into transport position. At the same time the rotor with its folded tine arms locks into place. The wing is secure.

Flexible and agile

Courtesy of its 20° steering angle, this rake with castoring rotor does an absolutely clean job in corners and curves. Nothing is left behind. This is the machine's biggest advantage and this is why this KRONE Swadro single-rotor rake is so popular among customers who farm small and awkwardly shaped fields.





Swadro 38 T, 42 T and 46 T

Trailed single-rotor rakes

- Wide working width
- Low power input
- Parallel-linkage controlled drawbar
- Standard tandem axle and 18" tyres
- Swadro 38 T and 42 T not available in Germany



Issues with a seized hitch ring?

Not with the parallel-linkage steering control and the height-adjustable pivoting drawbar or linkage drawbar. The hydraulic ram on the drawbar levels the rotor during lifts and lowering.

High ground clearance

The rotors are lifted out hydraulically. These rakes offer a 500 mm (1'8") ground clearance courtesy of the tandem running gear and the special attachment of the hydraulic cylinder. The perfect machine for crossing windrows.

Nothing is left behind

Adjusting the work height is easy by telescoping and securing the box section arms with a pin.



Combi running gear for safe and smooth road travel

The 38 T, 42 T and 46 T additions to the Swadro model range were developed in response to farmer demands for a trailed and well-proven single-rotor rake that offers the well-proven Swadro technology. The tandem axle on these models serves also as transport running gear.



Low power input

It is not pto power that limits the output of a single-rotor rake but the risk of too little load on the tractor's front axle as the machine is being lifted out of work. The answer to this problem is Swadro 38 T, 42 T and 46 T. These trailed models were designed for small and light tractors and applications in sloping fields. They stand out for low tractor power input and are coupled to a rigid drawbar or with a floating drawbar – quick and easy.

The tandem axle

The tandem axle runs on 18" Super Balloon flotation tyres. Raking up every haulm and offering a crank handle that controls the rake's lateral tilt, the machine ensures effective raking even in heavy crops.

Cleanest rakes in any condition

The castoring jockey wheel is standard specification on the Swadro 46 T models and an option on the 42 T model, allowing the machines to tackle even the tightest turns. The working height is easily set by refitting a pin.

Narrow transport width

The side arms on Swadro 46 T fold up easily to provide a compact transport unit and safe travel.



Swadro 710/26 T

The flexible side delivery rake

- Single and double-windrow presentation
- Windrowing to the right
- Variable work width
- Cardanic rotor suspension
- Hydraulic crop deflector adjustment
- 13 tine arms per rotor



Safe attachment

The drawbar – floating drawbar or linkage drawbar – is height-adjustable and the hitch ring is controlled by a parallel linkage. The hydraulic ram on the drawbar maintains the leading rotor parallel to the ground as it is lifted and lowered.



Tandem axles

A wide wheelbase with 18" wheels provides excellent contouring. The leading wheels run far on the outside to provide optimum stability in sloping terrain. Working height adjustment is via these pin setting systems.

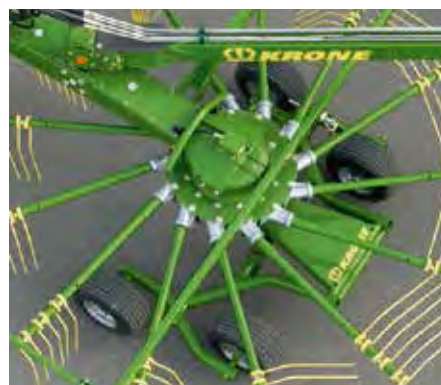

Lateral rotor tilt control

Clean and loss-free rakes are the foremost goal that has to be achieved in heavy crop as well. Adjusting the rotor's lateral tilt is easy from this threaded spindle, so that the rotors also pick up the extra material that is building up on the curtain.



Three features – great versatility

Featuring as many as 13 tines, this KRONE 710/26

T twin-rotor side delivery rake not only offers excellent value for money but also the cleanest rakes. Swadro 710/26 T

forms single and double windrows as well

as two narrow windrows. Naturally it offers hydraulic work width adjustment and thereby windrow width control, which is achieved by adjusting the main beam.



*Forming one single windrow
Raking 6.20 m (20'4") into one windrow*



*Forming two windrows
Raking 6.80 m (22'4") into two windrows*



*Forming double windrows
Raking 12.40 m (40'8") into one double windrow*



In this position the machine presents one windrow to the right
This is ideal for high-capacity harvesters and light crops.



Rear rotor goes left or right
Simply operate a crank from the tractor seat. It's quick and easy. During single windrow presentation, the swivel cylinder varies also the work width.



In this position the machine is forming two windrows, presenting them on the right hand side
This is the ideal configuration for small-capacity harvesters, for dense and leafy crops, and night windrows.



Swadro 710/26 T

The versatile machine



Approved for 40 km/h

Quick travel between fields save unproductive time and helps boost your daily output. The wide Tandem axles and 18" wheels provide the proper gear to achieve just that.



Ingenious

The cardanic suspension on the front rotor is implemented by operating the ram inside the drawbar in float position and by having the rear rotor move in an elongated hole. The result speaks for itself – a large pivoting range and optimum control.



The cardanic rotor suspension system

Technology that excites – the cardanic suspension system provides the rotors with three-dimensional movement including in direction of travel so they can adapt to any type of terrain. No matter whether in hilly or undulating fields – the KRONE Swadro rakes always deliver cleanest sweeps. Nothing is left behind.



Reasons for choosing Swadro 710 T with 26 tine arms

Because it is so versatile. Because it forms single windrows from variable work widths. It also produces two night windrows that can easily be picked up by low-capacity harvesters and does so in one single operation. It also scores on its compact transport dimensions, easy attachment and removal and instant changeovers to road travel.



Perfect for right-hand presentation

The controls are also arranged on the operator's right-hand side in the cab for maximum convenience.



Leading land wheels combine with cardanic rotor suspension for perfect rotor control

These castoring and height adjustable wheels can also be offset to one side depending on the crop volume.



Rugged

The sturdy box section beam absorbs any stress and strain, offering great stability when travelling at speed and working in difficult terrain.



No need to leave the cab

The rear rotor features hydraulic crop deflector control for convenient adjustment from the tractor seat. The curtain retracts hydraulically into transport position.



Swadro TS and TS Twin

Trailed twin-rotor side delivery rakes

- Perfect for single and double-windrow presentation as well as two windrows
- Easy handling on the headland and high rotor lift-out
- Very compact transport position



Single-windrow presentation

The Swadro TS models can be adapted to the crop conditions and the intake capacity of the following harvester. Single windrows are ideal in low-yielding crops and when using balers or forage wagons. The leading rotor spins faster than the rear unit, which eliminates roping.



Double-windrow presentation

Raking up two separate windrows in up and down operation, Swadro TS delivers a maximum work width of up to 15 m (49'3"). Double windrowing is a very effective method to fully exploit the intake capacities of powerful harvest machines.



The versatile twin-rotor side delivery rakes

The trailed KRONE Swadro TS side delivery rakes work at widths between 6.20 m (20'4") and 7.40 m (24'3") presenting the crop in single and double windrows. Swadro TS Twin implements double windrows as an option. As a result, the machine covers work widths between 6.92 m (22'8") and 8.20 m (26'11").



Quick changeover to making two windrows

Changing Swadro TS Twin from single-windrowing to dual windrowing is easy and straightforward. Simply telescope the two arms to accommodate the second windrow. Then fold down the leading windrow deflector.



Comparing Swadro TS and TS Twin

Swadro TS	Swadro TS Twin
Single-windrow presentation (standard)	Single-windrow presentation (standard)
	Double-windrow presentation - Telescoping hydraulic arms (standard) - Front crop deflector (option)

Producing two windrows with TS Twin

Swadro TS Twin has telescoping arms as standard. An optional crop deflector is available to complement the dual windrow presenting specification.



Easy-use windrow deflectors

The leading curtain is adjusted manually with the help of a spring whereas the rear curtain swings automatically into work position as the rotor lowers into work. It is also possible to adjust the rear curtain's ground clearance and alignment in direction of travel as well its distance to the rotor.





Swadro TS and TS Twin

Greatest height control for the rotors for high-quality forage



Rotor height control

An optimum quality of work requires rotors that work cleanly, consistently and loss-free. It is possible to set the tine clearance separately on each rotor – either manually or electrically as an option, using servomotors.



Manual rotor height control

Easy-to-get-at cranks out on the rotors are base specification to adjust the rotors' work height steplessly. A large scale indicates the current position and allows easy adjustment so that both rotors can be set very accurately and down to the millimetre.



The electric height control system

If varying conditions call for frequent depth changes, the electric control system may be a good option. The electric system is operated from a control box that is mounted in the tractor cab. From here operators control two servomotors which set the rotor height on the move and down to the millimetre and without any downtime.



Consistent ends

A hydraulic sequence control moves the leading rotor first and then the rear rotor into headland position. The hydraulic valves that are required to implement sequence control are controlled mechanically via a robust shift gate. Operators can set the delay between raising the front and rear arms.



High-stability frame with generous clearance

The use of large-diameter tubes gives the running gear and frame a particular strength. The high-clearance frame combines with the high rotor lift-out to raise the tines 50 cm (1'8") clear off the ground, leaving big windrows undisturbed.



Side-mounted main gearboxes and coil springs

The two main gearboxes were moved clear away from the centre of the machine, which helps ensure smooth driveshaft running also in headland position. In work, strong tension springs shift the weight to the frame and the undercarriage, thereby taking load off the rotors.



Swadro TS and TS Twin

Easy steering and safe road travel



Convenient transport height

The machine folds to a transport height of less than 4 m (13'2"), with arms moving up hydraulically and the curtain on the side lowering automatically.



Choice of tyres

Choose between two tyre specifications. All Swadro TS and TS Twin can be fitted with 11.5/80-15.3/10 PR (pic. 1) or 15.0/55-17/10 PR (pic. 2) tyres. The former provide good traction in softer soil conditions whereas the latter suit work in sloping fields. When folded into transport position, the machine measures a maximum of 2.90 metres (9'6") in width.

Altering the track width

If the wheels are fitted with slim tyres, it will be possible to expand the track width by 6 cm (2.4"). Simply refit a distancer sleeve on the wheel arms and move each axle out 3 cm (1.2").



A very nimble machine

All Swadro TS and TS Twin rely on a ball bearing that joins the two-point headstock to the frame. In turns, a rod controls the undercarriage's Ackerman steering system, which gives the rake great manoeuvrability so it can enter awkward areas without shunting. No crop is left behind.



Swift and safe travel

The great chassis stability gives all Swadro TS rakes excellent tracking even at higher speeds.





Swadro 1010

The side delivery rake with three rotors

- 9.70 m (31'10") work width for highest work rates
- Height control via electric servomotors
- Transport running gear for high operator comfort
- Cardanic suspension for optimum contouring
- The KRONE Jet Effect



Contaminated forage? No, thank you.

As conditions vary within one field it is essential to adapt the working height instantly. In this case, the driver operates weather-proof electric servomotors from an electric control box.



Perfect guidance

Combining a Tridem running gear and a cardanic rotor suspension system results in cleanest rakes in undulating terrain as well. The front wheels are connected by track rods and give excellent castering in tightest turns.



Ackerman steering

Optimum castering and excellent manoeuvrability. The wide transport running gear runs on oversized tyres (15.55 - 17 IMPL 10 PR) that give stability and protect the sward.



Powerful and maneuverable

Raking nearly 20 metres (65'7") into one double windrow, the KRONE Swadro 1010 is the ideal match for a high-capacity precision-chop forage harvester. Offering stunning work rates of up to 10 ha/h, this machine is the performance booster of your harvest chain. Running on a wide wheel base and steered via an Ackerman system, this high-capacity rake offers an enormous agility and very easy manoeuvring.



Perfectly orchestrated rotors

Raking 9.7 metres (31'10") into one windrow takes a machine which has all its components working in full sync. Therefore we designed Swadro 1010 which uses rotors of different diameters and speeds. The leading rotor has 10 tine arms whereas the rotors in the middle and at the rear count 13. At the same time, the leading rotor and the rotor in the middle spin at higher speeds than the unit at the rear – a detail that results in a smoother crop flow. Each tine arm on the lower-speed rotor carries 5 double tines which deliver the necessary vigour to handle those masses of crops and form the windrow.

Fast travel at 40 km/h (25 mph) and a 3 m (9'10") transport width

The three rotors change quickly into transport position. The central rotor measures less than 3 m (9'10") in diameter and so its tine arms are not folded to achieve a good transport height.



A perfect harvest chain at 9.70 m (31'10")

The tractor will not run on the crop but in the wheelings of KRONE's BiG M 420 high-capacity mower conditioner.

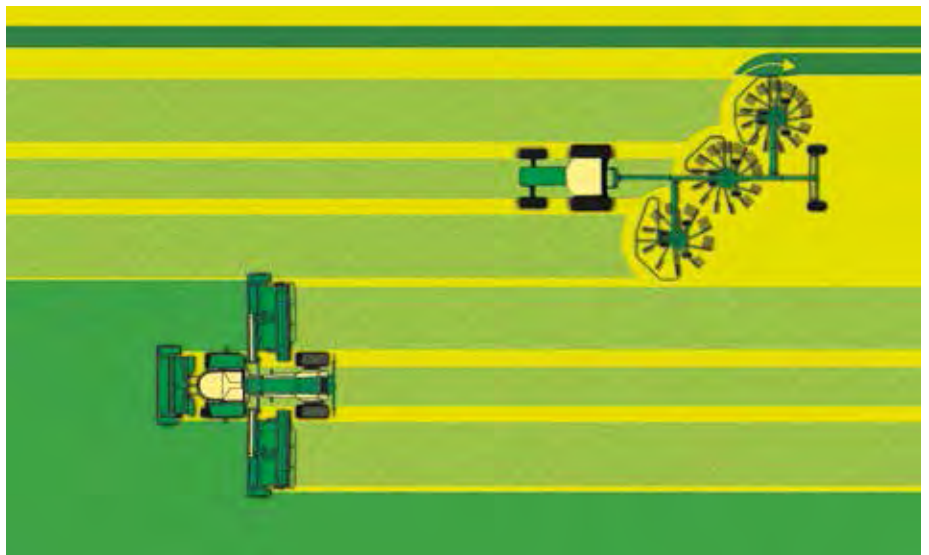



Swadro TC

Trailed twin-rotor centre delivery rakes

- Flexible work widths, extra high lift-out
- Variable running gear with adjustable track widths and large tyres
- Easy handling on the headland and high rotor lift-out



Swadro TC 640, work width: 5.70 m - 6.40 m (18'8" - 20'12")
Swadro TC 680, work width: 6.80 m (22'4")



Swadro TC 760, work width: 6.80 m - 7.60 m (22'4" - 24'11")
Swadro TC 880, work width: 7.60 m - 8.80 m (24'11" - 28'10")



Swadro TC 930, work width: 8.10 m - 9.30 m (26'7" - 30'6")



Swadro TC 1000, work width: 8.90 m - 10.00 m (29'2" - 32'10")

The flexible twin-rotor centre delivery rakes

The TC centre delivery rakes stand out for producing exceptionally consistent windrows while working at extremely high rates, flexible work widths and maximum ha/h performance. The range lines up two models and work widths – 5.70 m and 10.00 m (18'8" and 32'10").



The mechanical width control

If specified with mechanical width control, the arms extend and retract as the operator turns a crank.



The hydraulic working width control

Swadro TC 760 Plus is the entry model in the range which offers hydraulic work width control as standard specification. A large scale helps operators to determine the current position.



Individual rotor lift-out

The rotors can be raised individually out of work, an option that brings great advantages in wedges, along boundaries and in low-yielding crops.



The rotor suspension system

Strong tension springs can transfer some of the weight to the frame and the running gear on the move.



Swadro TC and TC Plus

Convenient height control and optional disturbing rotors for optimum forage quality



The manual height control system

All Swadro TC rotors have their height adjusted down to the millimetre on a crank which is arranged at a convenient height out on the rotor. A large scale helps operators to determine the current position.



The electric height control system

Those who often use the rake in varying conditions will find it helpful to opt for the electric rotor height control system. This is standard specification on all Swadro TC Plus models. From the cab, operators control two servo-motors which change the rotor height conveniently and accurately.



The electric control box

The operator adjusts and reads the current height of both rotors on the electric control box and also uses it to raise the rotors individually.



The unique disturbing rotor

Swadro TC 680 and 760 can be equipped with a new development from KRONE – a hydraulic rotor in the middle of the machine which uses 6 tines that disturb and aerate dry and light material. The hydraulic disturber promotes uniform wilting and ultimately the quality of hay and leafy forage such as lucerne.





Swadro TC and TC Plus

Great ground clearance and agility combine with a low transport height and safe travel on public roads



Generous ground clearance

The high-clearance frame and the high rotor lift-out allow the machine to run over massive windrows without disturbing them.



An extremely nimble machine

Swadro TC and TC Plus are attached to the two-point headstock by a ball bearing joint and a rod steered undercarriage with articulated steering. This combination makes these rakes particularly manoeuvrable – a special boon in awkward areas where no crop is left behind and no shunting is required. The machine simply goes into every corner of the field without manoeuvring.





Swift and safe travel

Great stability across the direction of travel and exceptional casting are the stand-out features of those undercarriages that are approved to 40 km/h (25 mph).

Reduced transport height

Quick changeovers: bring down the transport height to less than 4 m (13'2"), fold up the rotors without removing any tine arms or guards first, and retract the telescoping arms to reduce the machine width.



Choice of tyres

All Swadro TC and TC Plus running gears can be fitted with 10.0/75-15.3 (11.5/80- 15.3/10 PR on TC 880, pic. 1) or 15.0/55-17/10 PR (pic. 2) tyres

that suit softer soils conditions or work in sloping fields. Both types of wheels offer a maximum transport of less than 3 m (9'10").

Adjusting the track width

If the wheels are fitted with slim tyres, it will be possible to expand the track width by 6 cm (2.4"). Simply refit a sleeve distancer on the wheel arms and pull out each axle 3 cm (1.2").

Swadro 1400 and 1400 Plus

Trailed four-rotor centre delivery rakes

- Variable, up to 13.50 m (44'4") work widths
- Convenient handling from a choice of KRONE operator terminals or an existing in-cab ISOBUS terminal
- Foldable tines (Swadro 1400) or a hydraulically lowering running gear (Swadro 1400 Plus) reduce the transport height to less than 4 m (13'2")



Robust and flexible rotors

All rotors have cardanic suspension for best contouring and each rotor has 13 tine arms, each being equipped with four double Lift Tines.

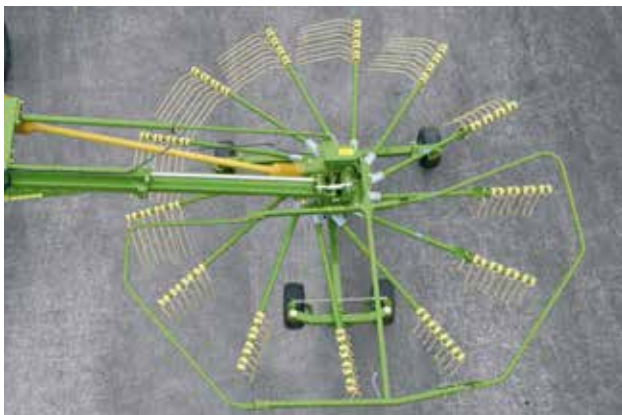

The KRONE Tridem running gear

The Tridem bogies have two standard castoring wheels clad with wide tyres running on the front and rear axle. The rear axle can take offset castoring wheels in a tandem arrangement, offering particularly smooth rotor control and running in difficult terrain.



The high-performance four-rotor centre delivery rakes

Swadro 1400 and 1400 Plus from KRONE have four rotors that work at variable widths between 11.00 m (36'1") and 13.50 m (44'4") and easily achieve work rates of up to 13 ha (32 acres) per hour. These machines stand out for high capacity, quick changeovers, rapid travel, great longevity and easy use. Their enormous efficiency makes Swadro 1400 and 1400 Plus very viable machines that meet the demands of contractors and coops.



Swadro 1400 and Swadro 1400 Plus in comparison

Swadro 1400

Transport height is less than 4 m (13'2") after the tine arms are folded mechanically (standard)

Electric height control

- For each individual rotor (standard)
- Set the height on one rotor and the remaining three rotors adjust automatically (option)

Swadro 1400 Plus

Transport height is less than 4 m (13'2") after the transport running gear lowers hydraulically (standard)

Electric Comfort rotor height control

- Set the height on one rotor and the remaining three rotors adjust automatically (standard)
- Height indicator works down to the millimetre on the operator terminal

Stronger driveshafts



Swadro 1400 and 1400 Plus

High-clearance frame, variable widths

Great frame stability

Designed to perform in professional applications that subject the material to great stresses and strains, Swadro 1400/1400 Plus was given an extremely robust frame to meet those stringent user demands.

High-clearance frame and wide lift-out

The special attachment of the rotor arms and the fact that the main beam remains level ensure the rotors can lift out high. A sequence control system always lifts and lowers the leading rotors first and the rear rotors only afterwards to produce uniform ends.



Variable working and windrowing widths

Vary the work width easily from 11 m (36'1") to 13.50 m (44'4") and adapt to any field situation. At the same time, vary windrow widths from about 1.40 m (4'7") to 2.20 m (7'3") by adjusting the rear rotors. The leading rotors operate at higher speeds than the ones at the rear, throwing the crop wide and ahead of the rear rotors which rake it into uniform and fluffy windrows without roping.

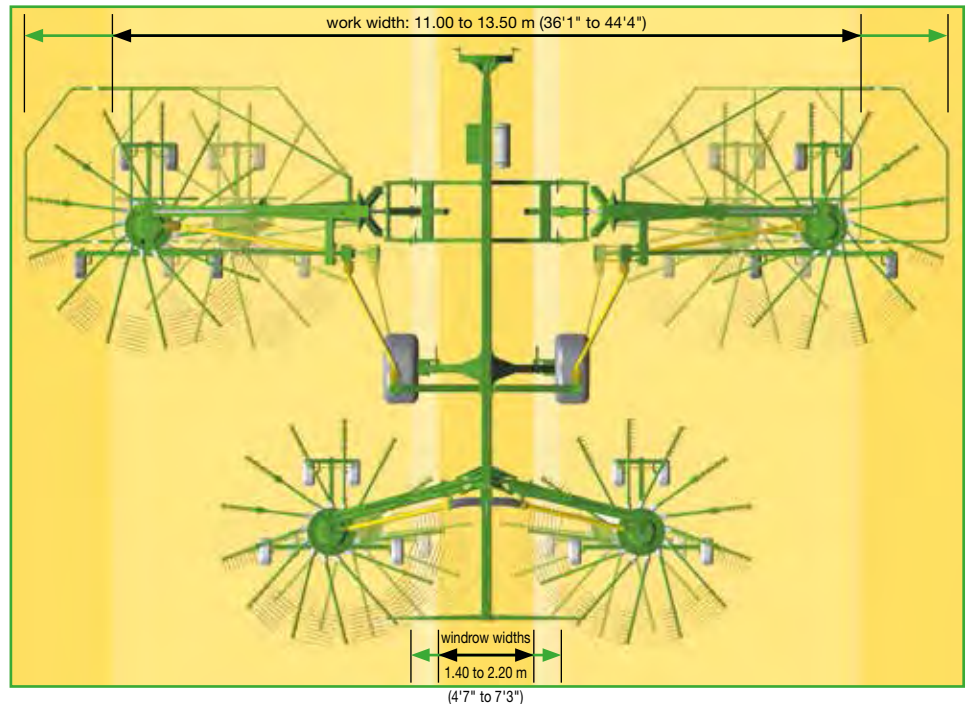

Optimized driveline

Movable gearboxes mount far out on the wings to optimize the driveline. Swadro 1400 Plus features heavy-duty driveshafts and the rotors are protected by star ratchet clutches.



Spring-loaded arms

Tension springs shift much of the arm and rotor weight to the main frame, thereby preventing the rotors from sinking into wet ground and ensuring positive tracking in sloping fields.





Swadro 1400 and 1400 Plus

Easy operation

The hydraulic working width control

The work width on the front and rear rotors is adjusted by telescoping the arms hydraulically, thereby moving also the positions of the right-angle gearboxes which drive the front rotors. This system warrants effective overlapping of both ends of the driveshafts irrespective of the current work width.



The electric control work height control

Controlling the height of the rotors conveniently from a cab-based terminal with large display screen is standard specification on these models. This way, the operator adjusts all rotors at once or each rotor individually. Swadro 1400 Plus allows operators to set the height on one rotor and then have all others adopt the current setting.



On-board electronic box enhances operator comfort



All major functions of Swadro 1400 / 1400 Plus are controlled by the ISOBUS-compatible KRONE on-board control box which is operated from a cab-based operator terminal such as Alpha, Delta, CCI 200 or any other ISOBUS-compatible tractor terminal.



The ISOBUS-compatible tractor terminal
Here is an example of an ISOBUS-compatible tractor terminal which controls all major machine functions.



The Alpha control box

The Alpha control unit Swadro 1400 gives finger-tip control of rotor height, work width and windrowing width as well as individual or sequential rotor up/down.



The Delta operator terminal

The Delta terminal has a colour display screen which shows the current settings. This terminal provides all Alpha features plus auto height control on Swadro 1400 Plus after the height was set on one rotor. An optional joystick is available to offer even more convenient operation.



CCI 200 operator terminal

This terminal offers the same features as Delta and is ISOBUS-compatible as well, which means it can be fitted to most ISOBUS machinery irrespective of the make. This terminal is also available with an optional joystick.



Swadro 1400 and 1400 Plus

Low transport height and safe road transport



Attaching to the tractor links

The two-point headstock pivots sideways, giving generous lateral movement without straining the driveshafts of course.



The ball hitch

The rake is also available with a ball hitch system which makes for easy and fast attachment and removal. Also, there is no jolting and travel is safe and comfortable.

A comfortable transport height

All Swadro 1400 models have transport height of less than 4 m (13'2") after folding the outer tine arms (pic. 1). This is not necessary on the Swadro 1400 Plus where the undercarriage is simply lowered hydraulically.



The running gear

All Swadro 1400 models have running gears that offer wide trackwidths, big flotation tyres and air brakes. Giving a transport width of less than 3 m and transport height of less than 4 m, they can easily travel at 40 km/h (25 mph) on public roads.

The Swadro 1400 Plus runs on an undercarriage that offers hydraulic height control (pic. 2).



Choice of tyres

500/50-17/10 PR (pic. 3) tyres are standard specification, but bigger 620/40 R 22.5 rubber (pic. 4) is available too. This tyre has proven extremely well on soft ground. Both types of tyres are approved for 40 km/h (25 mph).

Swadro 2000

Trailed six-rotor centre delivery rakes

- Variable, 10.00 to 19.00 m (32'10" to 62'4") work widths
- Variable, up to 3.00 m (9'10") windrow widths
- Intelligent transport wheel steering



The flexible windrowing width

An optimal windrow width boosts the overall harvesting efficiency. The width of a windrow is altered by telescoping the rear arms hydraulically, which adjusts the distance between the two rotors at the rear. The telescoping arms adjust to widths between 1.80 m (5'11") and 3 m (9'10").

The giant centre delivery rake

Relying on six rotors and offering variable work widths between 10 m (32'10") and 19 m (62'4"), Swadro 2000 from KRONE is the biggest machine on the market which brings you unsurpassed efficiency, very little maintenance and fastest changeovers as well as high transport speeds, great longevity and a maximum of operator comfort and on top covers up to 20 hectares (49.5 acres) per hour.

The windrows produced by Swadro 2000 are about 30% shorter per hectare than those produced by a four-rotor rake.

A 30% shorter windrow translates into fewer passes and an up to 15% higher output of the following harvesters. As such, Swadro 2000 presents the ideal machine for large-scale and contracting operations.



The variable work width

The work width is adapted to the capacity of the following harvester by moving the arms hydraulically into the proper position, thereby varying the working width from 10 m to 19 m (32'10" to 62'4"). The two arms are synchronized by the sliding carriage as they move into position.





Swadro 2000

Easy handling

Different rotor speeds

The tines on the four rotor tines operate at a higher speed than the units at the rear. The effect of differing rotor speeds is that the windrows are produced without roping.

The rotors lift out of work

They can lift/lower individually, sequentially or simultaneously. A hydraulic sequence control system is a particular boon for easy operation. Furthermore, a GPS based SectionControl feature is available as an option which lifts out individual rotors.



Fingertip control of transport and work positions

All changeovers on Swadro 2000 are carried out from the tractor seat where the operator simply triggers a hydraulic sequence control which takes over and manages all steps and folding functions, taking off stress and strain from the operator.

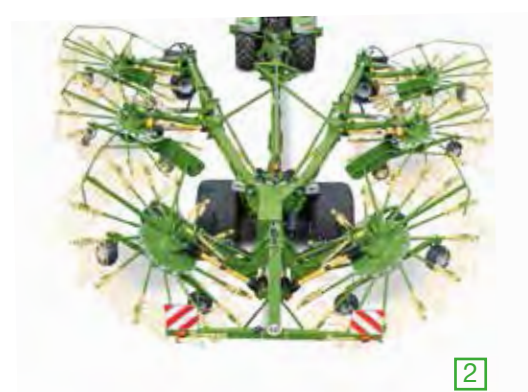

Auto control of transport and work positions

1. The rotors are raised into headland position (pic. 1)
2. The rear arms telescope in (pic. 2)
3. The leading arms slide inwards and the wheels fold up (pic. 2)
4. The rotors move into vertical position (pic. 3).

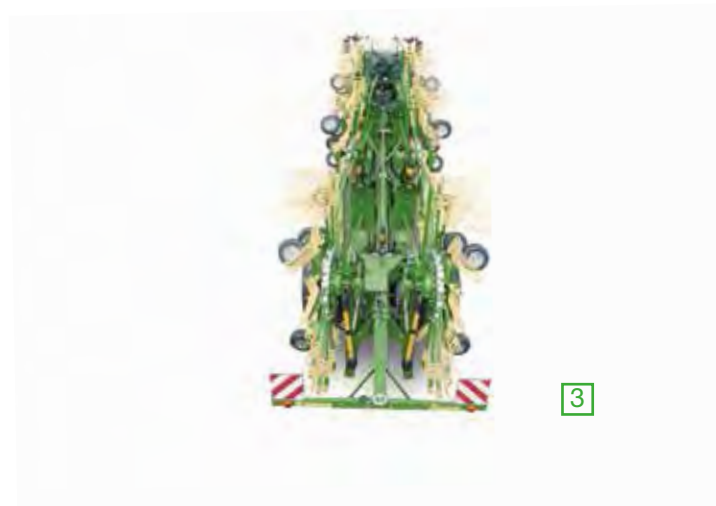



Swadro 2000

Safe travel on public roads



A robust linkage attachment

Swadro 2000 hitches to the tractor's link arms and its pivoting cat II/III headstock compensates for any humps and bumps while the strong stand provides uncompromised stability.



The beefy running gear

The transport running gear is approved to 40 km/h (25 mph) and is clad with big flotation tyres (800/45 R 26.5) to give exceptionally stable running on public roads and keep compaction and strain on the sward as low as possible.



Easy handling and great manoeuvrability

Flexible wheel steering

The Ackerman steering system on the transport running gear can be operated in two ways: either passively via a steering linkage or actively via a hydraulic system. Excellent castering, manoeuvring in tightest space and easy steering are the qualities that make this running gear stand out from everything else.



An extra hydraulic steering system

Those who find the steering angle provided by the mechanical system too small to manage narrow gates and those who do a lot of countersteering in sloping fields will appreciate the extra hydraulic steering system which relies on a hydraulic ram inside the steering linkage but allows operators to override the angle manually from the tractor seat.



Swadro 2000

Tremendously manoeuvrable – select from a range of axles



The unsteered axle

The axle on the running gear is switched off during work, which results in straight lines of uniform windrows.



The passive-steer axle

At rotor lift-out the steered axle is activated automatically and the running gear is steered via a rod, which makes Swadro 2000 more manoeuvrable and provides better casting.



The active-steer axle

The machine offers an extra steering system which can be activated when entering narrow gates and which allows the operator to steer the axle on the running gear actively via a hydraulic ram.



Swadro 2000

Great operator comfort from easy-use electronics

All major functions of Swadro 2000 Plus are controlled by the ISOBUS-compatible KRONE on-board control box, which is operated from the cab-based operator terminal Delta or CCI 200 or any other ISOBUS-compatible tractor.



The Delta operator terminal

The operator uses the Delta terminal with backlit display screen to enter the rotor height, work width and windrowing width and activate the sequential lift-out and lowering actions. This terminal provides auto height control for all rotors on Swadro 2000 Plus after setting the height of one rotor. An optional joystick is available to offer even more convenient operation.



CCI 200 operator terminal

This terminal offers the same features as Delta and is ISOBUS-compatible as well, which means it can be fitted to most ISOBUS machinery irrespective of the make. This terminal is also available with an optional joystick.



The ISOBUS-compatible tractor terminal

Here is an example of an ISOBUS-compatible tractor terminal which controls all machine functions.



Technical Data

Three-point linkage single-rotor models

		Swadro 35	Swadro 38	Swadro 42	Swadro 46
Work width	m	3.50 (11'6")	3.80 (12'6")	4.20 (13'9")	4.60 (15'1")
Area output	approx. ha/h	3	3.5-4	4-4.5	4.5-5
Transport width	m	1.90 (6'3")	1.90 (6'3")	2.26 (7'5")	2.55 (8'4")
No. of tine arms		10	10	13	13
No. of double tines		30	40	52	52
Rotor diameter	m	2.70 (8'10")	2.96 (9'8.5")	3.30 (10'10")	3.60 (11'10")
Tyre size on bogies		16x6.50-8	16x6.50-8	16x6.50-8	16x6.50-8
Input power	approx. kW/hp	22/31	22/31	37/50	37/50
Weight	approx. kg (lbs)	532 (1,173)	565 (1,246)	640 (1,411)	665 (1,466)
Three-point hitch		Standard	Standard	Standard	Standard
Storage length	m	3.04 (10')	3.39 (11'1.5")	3.69 (12'1")	3.99 (13'1")
Storage height	m	2.21 (7'3")	2.21 (7'3")	2.49 (8'2")	2.64 (8'8")



Trailed single-rotor rakes

		Swadro 38 T	Swadro 42 T	Swadro 46 T
Work width	m	3.80 (12'6")	4.20 (13'9")	4.60 (15'1")
Area output	approx. ha/h	3.5-4	4-4.5	4.5-5
Transport width	m	2.99 (9'10")	3.40* (11'2")	2.55 (8'4")
No. of tine arms		10	13	13
No. of double tines		40	52	52
Rotor diameter	m	2.96 (9'8.5")	3.30 (10'10")	3.60 (11'10")
Tyre size on bogies		18/8.5-8/6 PR	18/8.5-8/6 PR	18/8.5-8/6 PR
Input power	approx. kW/hp	19/25	22/31	22/31
Weight	approx. kg (lbs)	730 (1,609)	780 (1,720)	820 (1,808)
Drawbar		Standard	Standard	Standard
Storage length	m	4.80 (15'9")	4.95 (16'3")	5.10 (16'9")
Storage height	m	1.25 (4'1")	1.25 (4'1")	2.20 (7'3")

Swadro 38 T and 42 T (for export markets only)

* optional 2,26 m (7'5")



Technical data

Trailed two-rotor and three-rotor side delivery rakes

		Swadro 710/26 T	Swadro TS 620	Swadro TS 620 Twin
Work width at single-windrow presentation	m	6.20 (20'4")	6.20 (20'4")	6.20 (20'4")
	double-windrow presentation	2x3.40 (11'2")		2x3.46 (2x11'4")
Windrow width <small>(varies with crop yield and deflector curtain position)</small>	approx. m	0.80 - 1.40 (2'7.5" - 4'7")	1.10 - 1.60 (3'7" - 5'3")	1.10 - 1.60 (3'7" - 5'3")
Machine weight in standard specification	approx. kg (lbs)	1.600 (3,527)	2.050 (4,519)	2.150 (4,740)
Power requirement	approx. kW/hp	37/50	37/50	37/50
Acreage	approx. ha/h	5.5 - 6	6	6 - 7
Rotors				
Number		2	2	2
Diameter	m	2.96 (9'9")	2.96 (9'9")	2.96 (9'9")
Tine arms				
Number		2x13	10/13	10/13
rigid		Standard	Standard	Standard
foldable		–	Option	Option
Double Lift tines	number	91	96	96
Rotor height control mechanical, electric via control box		Standard	Standard Option	Standard Option
Tyres on bogies		18/8.5x8/6	16/6.50-8	16/6.50-8
Tyres on transport running gears				
Standard		–	11.5/80-15.3/10 PR	11.5/80-15.3/10 PR
Option		–	15.0/55-17/10 PR	15.0/55-17/10 PR
Transport width with standard tyres	approx. m	2.99 (9'10")	2.76 (9'1")	2.76 (9'1")
with optional tyres	approx. m	–	2.90 (9'6")	2.90 (9'6")
Transport height Arms rigid or folded out	m	1.35 (4'5")	3.90 (12'10")	3.90 (12'10")
Arms folded in	m	–	3.46 (11'4")	3.46 (11'4")
Storage length	m	8.40 (27'7")	8.00 (26'3")	8.00 (26'3")
Link arm attachment		Drawbar	Standard	Standard



Swadro TS 680	Swadro TS 680 Twin	Swadro TS 740	Swadro TS 740 Twin	Swadro 1010
6.80 (22'4")	6.80 (22'4") 2x3.80 (2x12'6")	7.40 (24'3")	7.40 (24'3") 2x4.10 (2x13'5")	9.70 (31'10")
1.10 - 1.60 (3'7" - 5'3")	1.10 - 1.60 (3'7" - 5'3")	1.20 - 1.60 (3'11" - 5'3")	1.20 - 1.60 (3'11" - 5'3")	1.00 - 1.80 (3'3" - 5'11")
2.200 (4,850)	2.250 (4,960)	2.400 (5,291)	2.400 (5,291)	2.920 (6,437)
37/50	37/50	37/50	37/50	59/80
6.5 - 7	6.5 - 8	7.5	7.5 - 8.5	9 - 10
2	2	2	2	3
3.30 (10'10")	3.30 (10'10")	3.60 (11'10")	3.60 (11'10")	1x2.96/2x3.60 (1x9'9"/2x11'10")
2x13 Standard Option	2x13 Standard Option	2x13 Standard Option	2x13 Standard Option	1x10/2x13 Standard -
104	104	104	104	157
Standard Option	Standard Option	Standard Option	Standard Option	- Standard*
16/6.50-8	16/6.50-8	16/6.50-8	16/6.50-8	16/6.50-8
11.5/80-15.3/10 PR 15.0/55-17/10 PR	11.5/80-15.3/10 PR 15.0/55-17/10 PR	11.5/80-15.3/10 PR 15.0/55-17/10 PR	11.5/80-15.3/10 PR 15.0/55-17/10 PR	15.0/55-17/10 PR -
2.76 (9'1")	2.76 (9'1")	2.76 (9'1")	2.76 (9'1")	2.99 (9'10")
2.90 (9'6")	2.90 (9'6")	2.90 (9'6")	2.90 (9'6")	-
3.99 (13'1")	3.99 (13'1")	3.99 (13'1")	3.99 (13'1")	4.45 (14'7")
3.55 (11'8")	3.55 (11'8")	3.55 (11'8")	3.55 (11'8")	3.95 (12'12")
8.30 (27'3")	8.30 (27'3")	8.65 (28'5")	8.65 (28'5")	9.80 (32'2")
Standard	Standard	Standard	Standard	Standard

* not indicated



Technical data

Trailed two-rotor centre delivery rakes Swadro

		Swadro TC 640	Swadro TC 680	Swadro TC 760	Swadro TC 880	Swadro TC 930	Swadro TC 1000
Working width	m	5.70-6.40 (18'8"-20'12")	6.80 (22'4")	6.80-7.60 (22'4"-24'11")	7.60-8.80 (24'11"-28'11")	8.10-9.30 (26'7"-30'6")	8.90-10.00 (29'2"-32'10")
Work width control							
mechanical		Serie	–	Standard	–	–	–
hydraulic		Option	–	Option	Standard	Standard	Standard
Windrowing width	m	1.00-1.70 (3'3"-5'7")	1.00 (3'3")	1.00-1.80 (3'3"-5'11")	1.30-2.50 (4'3"-8'2")	1.30-2.50 (4'3"-8'2")	1.30-2.50 (4'3"-8'2")
Machine weight in standard specification	approx. kg (lbs)	1,400 (3,086)	1,700 (3,748)	1,950 (4,299)	2,300 (5,071)	2,780 (6,129)	3,000 (6,614)
Power requirement	approx. kW/hp	22/35	37/50	37/50	40/55	51/70	51/70
Acreage	approx. ha/h	5,5-6	6,5-7	7,5	8-8,5	9-9,5	9,5-10
Rotors							
Number		2	2	2	2	2	2
Diameter	m	2.70 (8'10")	3.30 (10'10")	3.30 (10'10")	3.60 (11'10")	3.80 (12'6")	4.20 (13'9")
Tine arms							
Number		2x10	2 x 10	2 x 13	2 x 13	2 x 15	2 x 15
rigid		Serie	Standard	Standard	Standard	Standard	–
foldable		–	Option	Option	Option	Option	Standard
Double Lift tines	number	60	80	104	104	120	120
Rotor height control							
mechanical		Standard	Standard	Standard	Standard	Standard	Standard
electric via control box		–	–	Option	Option	Option	Option
Tyres on bogies							
Standard		16/6.50-8	16/6.50-8	16/6.50-8	16/6.50-8	16/6.50-8	16/6.50-8
Option		–	–	–	18/8.50-8	18/8.50-8	18/8.50-8
Separate rotor lift/lower feature		–	Option	Option	Option	Standard	Standard
Tyres on transport running gear							
Standard		10.0/75-15.3/8 PR	10.0/75-15.3/8 PR	10.0/75-15.3/8 PR	11.5/80-15.3/10 PR	10.0/75-15.3/8 PR	10.0/75-15.3/8 PR
Option		–	15.0/55-17/10 PR	15.0/55-17/10 PR	15.0/55-17/10 PR	15.0/55-17/10 PR	15.0/55-17/10 PR
Transport width							
with standard tyres	approx. m	2.54 (8'4")	2.72 (8'11")	2.72 (8'11")	2.86 (9'5")	2.86 (9'5")	2.86 (9'5")
with optional tyres	approx. m	–	2.89 (9'6")	2.89 (9'6")	2.99 (9'10")	2.99 (9'10")	2.99 (9'10")
Transport height							
Rigid arms or folded out	m	3.55-3.90 (11'8"-12'10")	3.99 (13'1")	3.99-4.39 (13'1"-14'5")	3.99 (13'1")	3.99 (13'1")	4.35 (13'1")
Arms folded in	m	–	3.55 (11'8")	3.57-3.97 (11'9"-13')	3.55 (11'8")	3.55 (11'8")	3.75 (12'4")
Storage length	m	4.82-5.39 (15'10"-17'8")	5.90 (19'4")	5.90 (19'4")	6.33 (20'9")	6.75 (22'2")	6.75 (22'2")
Attachment							
Link arms		Standard	Standard	Standard	Standard	Standard	Standard
Ball hitch		–	–	–	–	–	–



Technical data

Trailed four-rotor and six-rotor centre delivery rakes Swadro

		Swadro 1400	Swadro 1400 Plus	Swadro 2000
Working width	m	11.00 - 13.50 (36'1" - 44'4")	11.00 - 13.50 (36'1" - 44'4")	10.00 - 19.00 (32'10" - 62'4")
Work width control				
mechanical		–	–	–
hydraulic		Standard	Standard	Standard
Windrow width	m	1.40 - 2.20 (4'7" - 7'3")	1.40 - 2.20 (4'7" - 7'3")	1.80 - 3.00 (5'11" - 9'10")
Weight	approx. kg (lbs)	5.100 (11,243)	5.700 (12,566)	9.400 (20,723)
Input power	approx. kW/hp	59/80	59/80	96/130
Area output	approx. ha/h	12 - 14	12 - 14	20
Rotors				
Number		4	4	6
Diameter	m	3.60/3.30 (11'10"/10'10")	3.60/3.30 (11'10"/10'10")	3.30/3.30/3.38 (10'10"/10'10"/11'1")
Tine arms				
Number		4 x 13	4 x 13	4 x 13, 2 x 15
Rigid		–	Standard	Standard
Foldable		Standard	–	–
Lift double tines	number	208	208	328
Rotor height control				
mechanical		–	–	–
electric		Standard	Standard	Standard
Tyres on bogies		16/6.50-8	16/6.50-8	16/6.50-8
Separate rotor lift-out		Standard	Standard	Standard
Transport running gear tyres				
Standard		500/50-17	500/50-17	800/45 R 26.5
Option		620/40 R 22.5	620/40 R 22.5	
Transport width				
with standard tyres	approx. m	2.99 (9'10")	2.99 (9'10")	2.99 (9'10")
Transport height				
Tine arms (rigid or unfolded)	m	4.36 (14'4")	3.99 (13'1")	3.99 (13'1")
Tine arms (folded in)	m	3.85 (12'8")	–	–
Storage height				
Tine arms (rigid or unfolded)	m	4.36 (14'4")	4.07 (13'4")	3.99 (13'1")
Tine arms (folded in)	m	3.85 (12'8")	–	–
Storage length	m	8.55 (28'1")	8.71 (28'7")	13.20 (43'4")
Attachment				
Link arms		Standard	Standard	Standard
Ball hitch		Option	Option	–

Maschinenfabrik Bernard Krone

Perfect in every detail



Innovative, proficient and close to our customers – these are the keywords that mark the philosophy of our family-owned company. As a forage specialist, KRONE manufactures disc mowers, tedders, rakes, forage wagons, round and square balers as well as the high-capacity and self-propelled BiG M mower conditioners and our BiG X forage harvesters. Quality made in Spelle – since 1906.

Your KRONE dealer



Maschinenfabrik Bernard KRONE GmbH & Co. KG

Heinrich-Krone-Straße 10
D-48480 Spelle

Tel.: +49 (0) 5977.935-0
Fax: +49 (0) 5977.935-339

info.ldm@krone.de | www.krone.de