

*HighSpeed*

 **KRONE**

# BiG Pack

Large Square Balers



BiG Pack HighSpeed

[www.krone.de](http://www.krone.de)

# BiG Pack

## Large Square Balers



- **HighSpeed:** Higher piston stroke frequency leads to significantly higher bale densities and higher capacities  
Available on many models
- **HighSpeed:** Better access thanks to new plastic panels and twine boxes that open without tools
- **HighSpeed:** New LED lights are standard to illuminate the inside of the machine
- **HighSpeed:** Highest operator comfort thanks to the new colour touchscreen terminal
- **HighSpeed:** Up to 20 % higher throughputs by larger VFS system



**HighSpeed**



With the KRONE BiG Pack, you are always one step ahead. Baling up to 25% heavier bales with the BiG Pack HDP model and tying up to nine small bales into one big bale with the MultiBale system, you will be ahead of the field, using first-time innovations that you won't find anywhere else.



BiG Pack – the success range	4
EasyFlow pick-up	8
X-Cut cutting system	10
PreChop pre-cutting system	12
VFS – Variable Filling System	14
The baling chamber	16
The knotters	20
Control units	22
The running gear	24
BiG Pack 890, 1270, 1290	26
MultiBale	28
HDP	30
BiG Pack 4 x 4	34
Technical Data	38





# BiG Pack

## Large Square Balers

- A bale chamber up to 130 cm (4'3") in height
- Camless EasyFlow pick-up with powered feed roller
- VFS Variable Filling System
- KRONE X-Cut – the pull-out knife bed
- MultiBale packs up to nine small bales into one big bale
- HDP – High Density baling system













# BiG Pack: The product line that secures Success

With a KRONE large square baler you purchase experience and competence in baler design. From experience KRONE knows the widely differing field requirements and offers a complete baler range with standard bale chamber dimensions. Internationally recognized innovations, such as the Variable Fill System (VFS), the unique MultiBale model and the camless EasyFlow pick-up are some reasons for the success of the KRONE BiG Pack. It is a fact: KRONE makes what customers want.

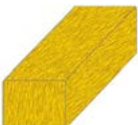

The BiG Pack range

	BiG Pack 890 BiG Pack 890 X-Cut	80 x 90 cm (2'7.5" x 2'11")	
	BiG Pack 1270 BiG Pack 1270 X-Cut	120 x 70 cm (3'11" x 2'4")	
	BiG Pack 1270 MultiBale BiG Pack 1270 X-Cut MultiBale	9 small bales 120 x 70 cm (3'11" x 2'4") one large bale up to 270 cm (8'10")	
	BiG Pack 1290 BiG Pack 1290 X-Cut	120 x 90 cm (3'11" x 2'11")	
	BiG Pack 1290 HDP BiG Pack 1290 HDP X-Cut	120 x 90 cm (3'11" x 2'11")	
	BiG Pack 4x4 BiG Pack 4x4 X-Cut	120 x 130 cm (3'11" x 4'3")	



## The BiG Pack HighSpeed product line



### **BiG Pack 890 (X-Cut):**

The smallest of all BiG Packs. With four double knotters and Bale chamber dimensions of 80 cm (2'7.5") height and 90 cm (2'11") width, this machine has proven itself, not only in straw, but also in heavy wet Silage.



### **BiG Pack 1270 (X-Cut):**

This machine is used in conditions because of its chamber dimensions of 120 cm (3'11") height and 70 cm (2'4") width. Six Single or Double Knotters provide for well-shaped baling in Straw, Hay and Silage.



### **BiG Pack 1270 (X-Cut) MultiBale:**

With this version you can pack up to nine small bales in one large bale. Your benefits: The large bales can be cleared quickly from the field and the small bales can be easily distributed.





**BiG Pack 1290 (X-Cut):**

The firm bales with 90 cm (2'11") height and 120 cm (3'11") width is accepted by farmers worldwide. Because of the large bale dimensions, this machine works mainly in straw and hay, but in some countries it is commonly and successfully used in silage as well.



**BiG Pack 1290 (X-Cut) HDP:**

Make bales like bricks. The High Density baling system and the longer bale chamber lead to an increase in bale weight by up to 25 % over traditional systems. This pays for itself quickly when transporting straw.



**BiG Pack 4x4 (X-Cut):**

With 130 cm (4'3") chamber height you are making fewer bales per acre, saving time and labor costs and clearing the field quickly. This baler is used mainly in straw and hay and can be equipped with the X-Cut cutting system.

# Active Pick-up

Camless EasyFlow pick-up with powered feed roller

- 30 % higher pick-up speed for enhanced results
- Powered feed roller for superior performance in brittle material
- Camless design for quieter running
- 68 % fewer moving parts for low wear
- Maintenance-free and long-lasting

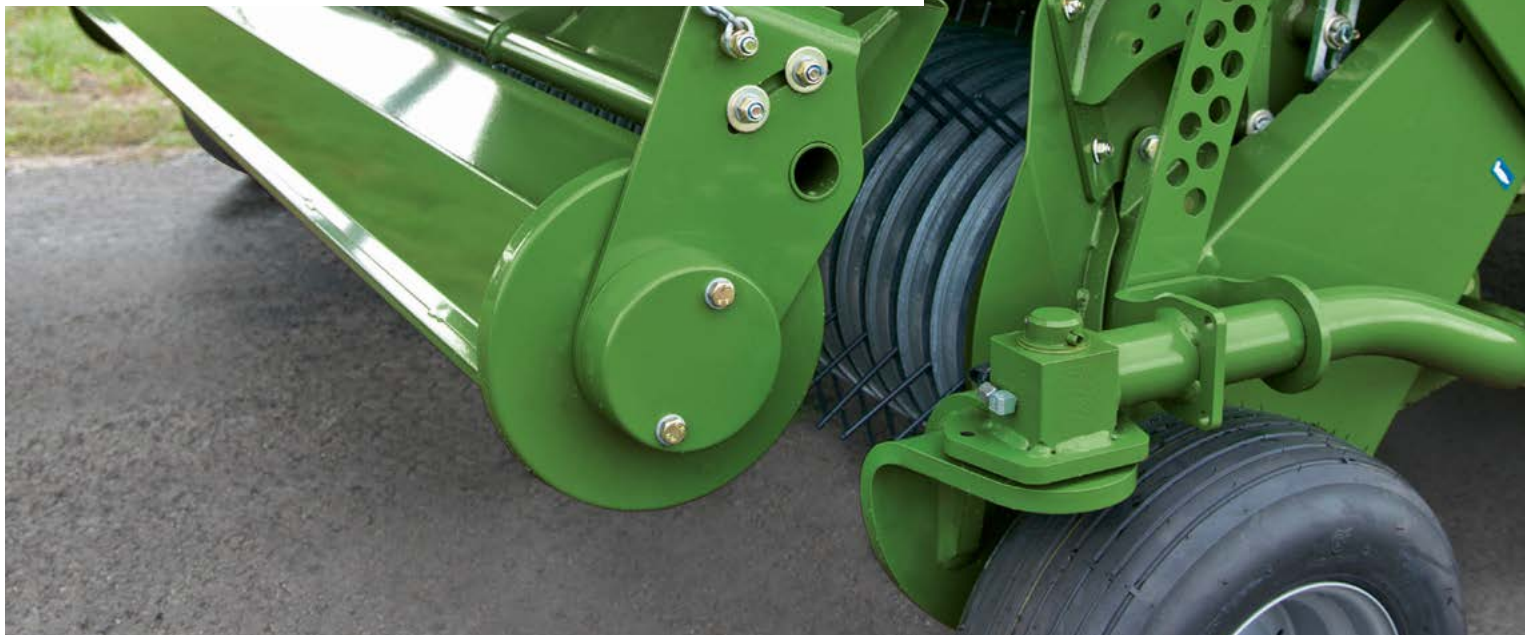

## Nothing is left behind

Working at a width of 2,350 mm (7'9") (DIN 11220) and specified with five rows of tines that are spaced 55 mm (2.2") apart, the camless EasyFlow pick-up gives absolutely clean rakes. Resulting in a substantial increase in throughput, the powered feed roller and the feed augers on either side tick all boxes in dry and brittle material. The special mounting of the massive crop press roller leads to an optimised crop flow in wide windrows.

## Gentle on the sward

The pneumatic caster wheels follow every curve and are adjusted in height without the need of tools. Their excellent castering capabilities result in less wear and tear on the mountings and better protection of the valuable sward.





# EasyFlow: The camless pick-up in a large square baler

With the EasyFlow pick-up KRONE offers for the first time a camless pick-up which functions without a complex cam track control. The secret of this pick-up is the wave-shaped design of the tine bands. You get the effect of tine retraction without the cam track drive. EasyFlow can work with 30 % higher speed allowing higher ground speed and an increased throughput.

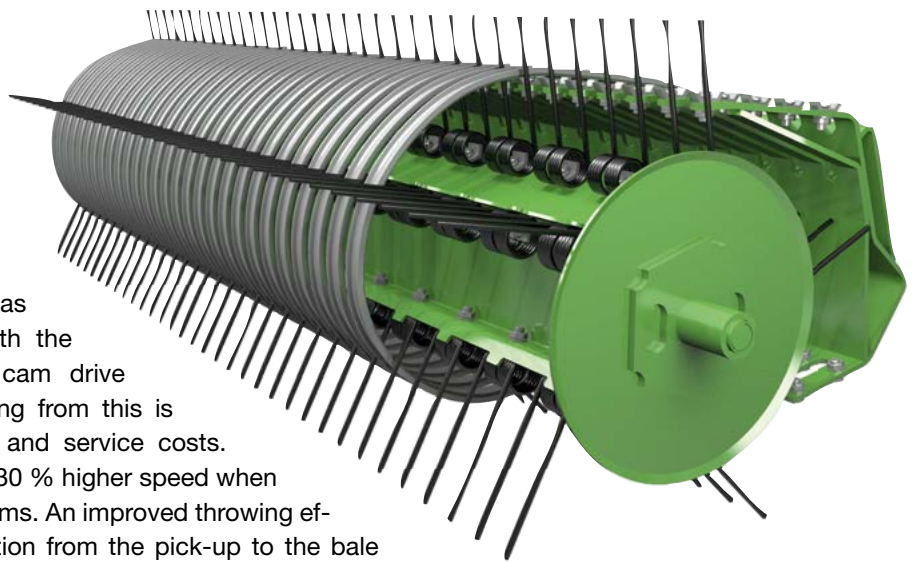

## The advantages are obvious:

The EasyFlow pick-up has clearly fewer moving parts with the elimination of the traditional cam drive design. The lower wear resulting from this is realized in lower maintenance and service costs. EasyFlow works within approx. 30 % higher speed when compared to conventional systems. An improved throwing effect results in the crop's transition from the pick-up to the bale chamber improving the pick-up's capacity and making the BiG Pack even more efficient.

## Standard depth control

The standard depth limiter adjusts the pick-up to work in long stubble, which reduces the strain on the gauge wheels, which will lift the pick-up in extremely undulating patches only.

## Standard crop press roller

The massive crop press roller ensures a continuous flow of crop into the machine, eliminating any risk of pushing up crop in uneven windrows. The machine operates permanently at maximum pick-up and output levels.

## The solution for higher operator comfort:

The drive through universal shaft with integrated ratchet clutch, which responds to pick-up overload. Changing shear bolts is not required.



# KRONE X-Cut

## Precision cuts

- 16 knives for 80 cm (2'7.5") chamber width  
26 knives for 120 cm (3'11") chamber width
- Tines feature wide and hard-wearing Hardox steel plates
- The knife bank with pull-out knife trays lowers hydraulically
- Knives are selected in sets
- MaxFlow Inside: an optimized crop flow for high throughput



### Strong rotor, strong cut:

The large diameter of 550 mm (1'10") is impressive. The double tines in sets of three across the full width of the cutting and feed rotor pass the crop efficiently across the knives because of the V-shaped arrangement.

### Direct-Drive:

The cutting and VFS rotor is driven directly off the main gearbox. Drive protection is provided by the integrated cam type clutch, which protects the cutting rotor against overload and resets itself automatically.

### Wide Hardox plates on the feed tines:

They result in higher throughputs, clean scissor-like cuts and harder wearing. The 20 mm (0.8") wide Hardox feed plates are a guarantee for quality forage. Any mushing is eliminated.

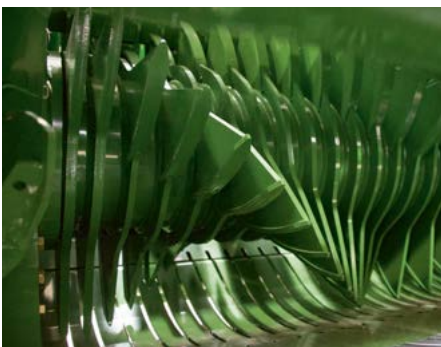



# Finest quality cuts!

Select 16 or 26 knives to achieve nominal cutting lengths of 44 mm (1.7"). The knife control system activates half of the number of knives or deactivates all knives. As a result, the machine is converted without tools and in no time at all. The feed tines are arranged in a V and are plated with wide Hardox steel to provide finest cuts, highest throughputs and maximum longevity. The knife floor is adapted to match the crop flow and increases machine efficiency.

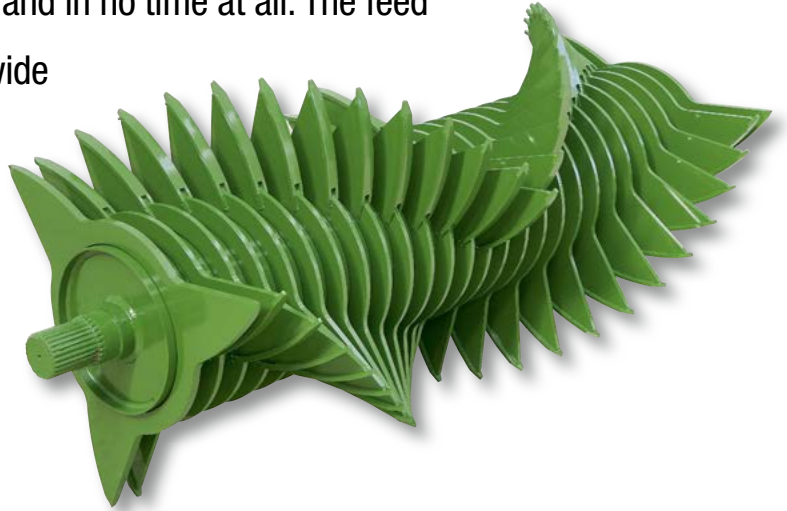

## The "Tray Principle":

The X-Cut cutting system has two knife drawers with either 8 or 13 knives. The drawers can be lowered hydraulically to install and remove the knives. For this purpose the knife drawers or "divided trays" can be conveniently pulled outwardly to the side. The exposed knives can be removed for maintenance work or for changing the cutting length. The knives can then be refitted. All without tools!



## X-Cut safety:

The spring protection for individual knives ensures trouble-free working if foreign objects are picked up. The knives conveniently push back into their working position after the foreign body has cleared.



## Quick and easy:

The central knife control system sets a variety of cutting lengths. Select half the number of knives to obtain a nominal length of 44 mm (1.7"); select the full set of knives for a length of 88 mm (3.5"). 0 position means the crop is not cut.



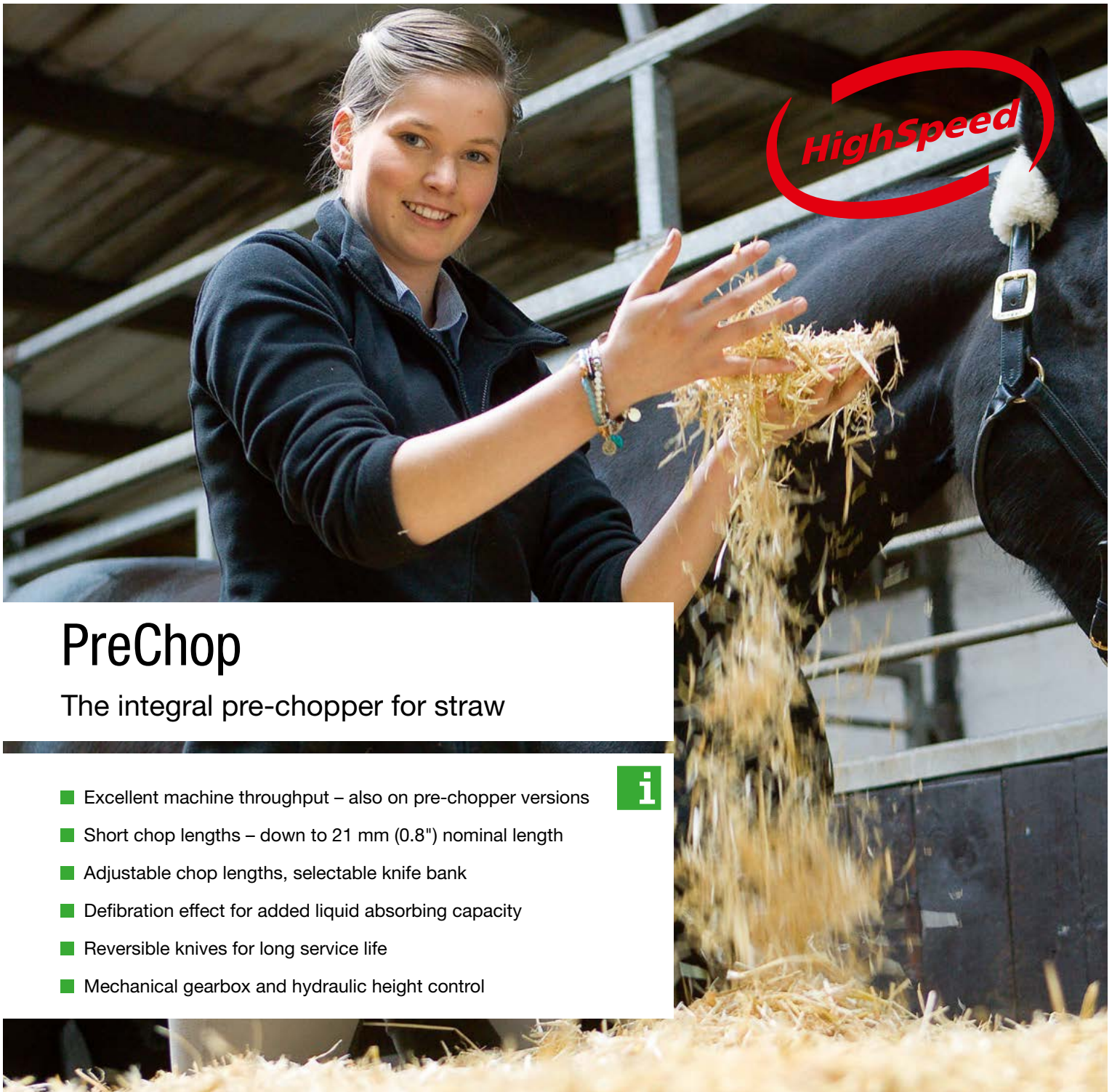

# PreChop

The integral pre-chopper for straw

- Excellent machine throughput – also on pre-chopper versions
- Short chop lengths – down to 21 mm (0.8") nominal length
- Adjustable chop lengths, selectable knife bank
- Defibrillation effect for added liquid absorbing capacity
- Reversible knives for long service life
- Mechanical gearbox and hydraulic height control



### An extra asset

The PreChop system adds value to the crop, because finely chopped and clean straw can be used in a wide variety of applications, including as bedding in poultry buildings and dairy cow beds, in sow and livestock fattening as well as on strawberry plantations and as nutrient medium in mushroom cultivations or as ingredients in low crude fibre rations. If treated, the straw has enhanced absorbing qualities, spreads more easily in the livestock building, and prevents the slurry drains from blocking up while supporting manure mineralization. The KRONE PreChop chopper caters for all these applications.



# The integral pre-chopper

PreChop is the integral pre-chopper for the KRONE

BiG Pack 1270 XC, 1290 XC und 1290 HDP XC

big baler ranges. Equipped with

88 rotary knives and two fixed

counter banks of knives in a

staggered arrangement, the unit

chops the crop to nominal lengths of

21 mm (0.8"). More than that, PreChop defibrates the stem visibly. The defibrated

crop flows smoothly through the baler and is baled into well-shaped bales that are

easy to handle.



## A modular system

So you want to use a PreChop system on your BiG Pack XC big baler? No problem, because your baler offers the flexibility to do just that. Its drawbar extends to provide sufficient space between the chopping unit and the tractor's rear wheels. The chopper itself is activated/deactivated conveniently from a mechanical gearbox. You can also use the baler without the PreChop unit: Just raise it 52 cm (1'8.5") clear of the ground and run over windrows without the PreChop unit picking them up.

## Chopping at its best

The cutting rotor is 525 mm (1'9") in diameter and features 88 pivoting knives in a helical arrangement. Rotating at 3,000 rpm, it feeds the material through a counter blade and on to the pick-up. The counter blade is made up of two bars, each equipped with 47 rigid knives. The bottom bar adjusts to one of five positions, the top knife to one of three and all knives are reversible for a long service life.

## Easy removal

You can easily remove the PreChop unit when you don't want pre-chopping for an extended period. Simply remove the pins and the driveshaft and then pull the unit out to the side on its transport rolls.



# VFS

## The Variable Fill System from KRONE

- High throughput, 5-phase feed sequence
- Pre-compression in the feed chamber, thus complete filling of the bale chamber
- Well-shaped bales even from small windrows
- Uniformly compressed bales for higher bale weights
- Automatic overload clutch for higher daily output, no downtime



### **BiG Pack HighSpeed – baling at two different pto speeds**

KRONE BiG Pack HighSpeed helps you to respond to any situation and application. Operate your BiG Pack baler at 1,000 rpm and 45 strokes/minute in big windrows and reduce pto speed to 800 rpm and stroke frequency to 36 strokes/minute when baling in low-yielding crop. At either speed, the bales are as hard as rocks while fuel consumption goes down.





# Rock Solid Bales

The Variable Fill System (VFS) from KRONE provides rock solid and well-formed bales, even in small windrows and at reduced forward speeds. The principle of the VFS system:

First, the packer and feeder tines convey the crop into the feed chamber where it is collected and pre-compressed. At the point when the feed chamber is completely filled, the feederrake conveys the crop into the bale chamber.



With the Variable Fill System KRONE once again offers a solution to improve a farmer's productivity. This is another classic example of the innovative force that characterizes KRONE designs. The VFS system combines the best features of continuous feed systems with the best features of volume-dependent systems and opens up completely new way for KRONE balers to produce exceptional large square bales.

**Fig. 1:** The VFS system operates with 4 packer rakes and one feeder rake as well as a retainer. The packers are controlled by a common cam track. The feeder rakes by a second rotating cam track.

**Fig. 2:** As long as the cam track of the feeder is not in the rotated position, the packer and feeder convey the crop permanently into the feed chamber and pre-compress it. The retainer holds back the crop under the bale chamber.

**Fig. 3:** Only when the feed chamber is full does the retainer hook automatically swing to the rear. This frees the transition into the bale chamber and at the same time releases a clutch.

**Fig. 4:** The clutch rotates the entire cam track of the feeder rake which now conveys the crop into the chamber. The retainer and feeder rake then swivel back automatically to their starting position.

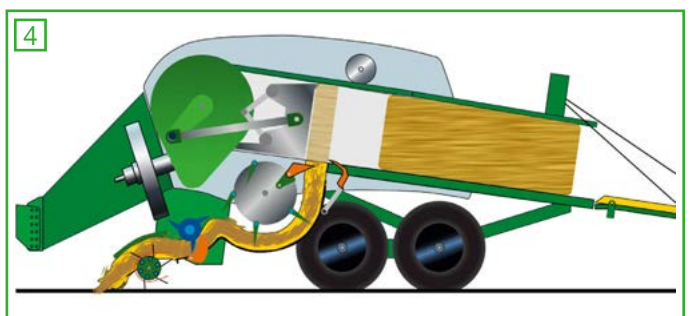
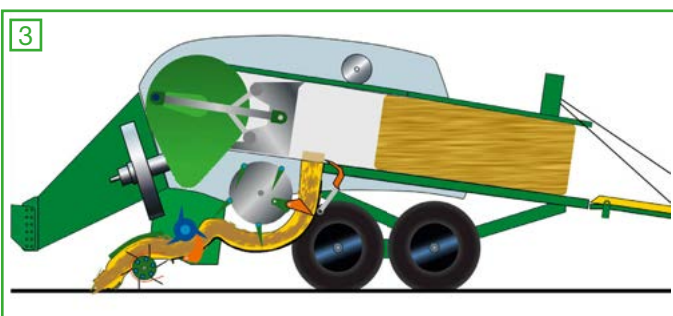
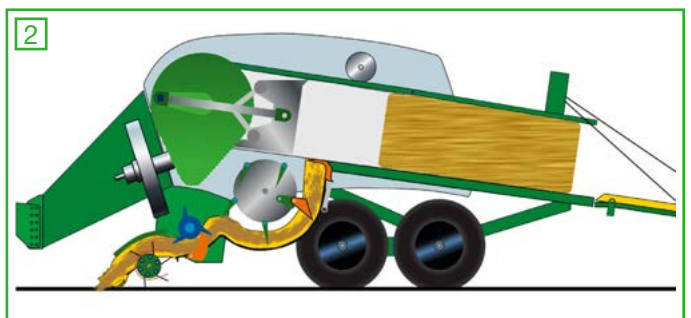
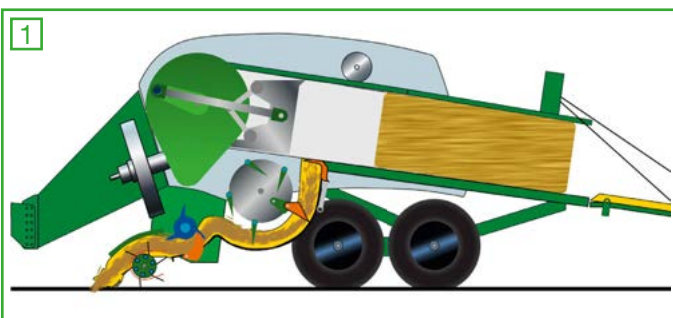



# The baling chamber

From the flywheel to the bale chute

- A huge momentum from a massive flywheel translates into smooth and quiet operation
- The power flows directly down clutch-protected driveshafts
- Higher throughputs from 18 % more piston strokes (BP 1270 and BP 1290/1290 HDP)
- The funnel-shaped baling chamber leads to a uniform pressure down the entire length of the chamber



### Exceptional protection of the entire drive:

At the front, the BiG Pack is protected by a friction clutch. In the case of overload on the machine side an automatic ratchet protection clutch is activated.



### Without diversions:

The power transmission to the packer gear and the knotters is directly through drive shafts instead of chains which are prone to wear and tear plus must be maintained. Customers can be assured of comfort, convenience and reliability with the KRONE direct drive system.

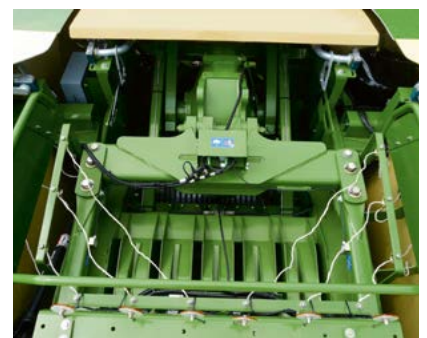

### The density is maintained across the chamber width

as one sensor on either wall measures the actual force of the stroke. A control system compares this measurement with the parameter set by the operator and corrects the pressure exerted on the chamber doors as necessary.



# Quiet operation and driver comfort

We know it too: Vibration building up and noisy operation – a feature of many traditional baler designs. One more reason why KRONE has used large flywheels right from the start. Load peaks are leveled out, the machine runs evenly and has a considerably lower power requirement.

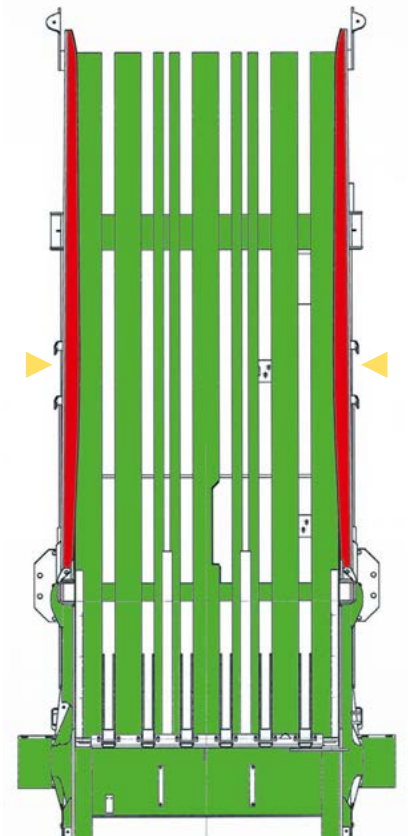

## Powerful and safe:

The KRONE big balers have extremely long plungers, which support the work of the needles. The plunger on BiG Pack 890 operates at 50 strokes/min, the plunger on BiG Pack 1270 and 1290 at 45 strokes/min and the unit on BiG Pack 4x4 at 38 strokes/min, ensuring quiet and smooth operation.

## High load capacity:

The plunger is centered in the chamber by the huge bearings. It can be adjusted in height by eccentric adjustment bolts through the bearings. Plus scrapers are equipped front and back of the bearings to clean the track out for that extra reliability.

## The funnel shaped bale chamber is the answer:

For highest bale densities the BiG Packs have long, funnel-shaped bale chambers with spring loaded hay dogs on the sides and top. The round ends of the doors guarantee smooth bale edges.



# The baling chamber

From the flywheel to the bale chute

- A sensor on the star wheel ensures uniform lengths – bale after bale
- Robust yoke with massive hydraulic rams for highest densities
- Baling force is measured electronically for uniform densities in varying conditions
- Optional bale moisture sensor integrated in baling chamber
- Optional weighing system integrated in bale chute



**Bale for bale, consistency in length:**  
The star wheel is mounted in a central location in the bale chamber floor. The bale is pushed over the star wheel providing an exact bale length measurement.



**Self contained, onboard hydraulics:**  
The hydraulic circuit is supplied from a separate onboard oil tank through a high-pressure pump driven by the main gearbox. That means the oil circuit is independent of the tractor hydraulic system, thus eliminating a possible source of contamination.



**Full hydraulic power for rock solid bales:**  
Up to 6 hydraulic cylinders (depending on machine model) operate the upper and side bale chamber doors for highest continuous loading in the bale chamber and bale ramp.



# In best shape

BiG Pack will be the baler for you. Produce rock-hard bales of uniform densities and with tidy and smooth edges. These are the qualities that made BiG Pack famous. The on-board hydraulic system with automatic baling force control ensures the shape and is maintained and the edges are tidy, even in moist conditions and varying crops. The long funnel-shaped baling chamber with its haydogs to temporarily retain the crop warrants highest baling densities.



## Watching the moisture

Optional sensors are fitted in the side doors and transfer their measurements to the terminal, keeping the operator constantly up to date.



## A new rear end

The rear end on the BiG Pack HighSpeed model features a substantially beefier frame to accommodate a hitch that allows bale collectors to be attached more easily.



## Simple and robust by design

The BiG Pack balers have a hydraulic bale chute as standard specification. The chute may be fitted with an optional and integral weighing system.



# KRONE knotting system

Single or Double Knotters

- High functional safety – good twine feed
- Compressed air cleaning – standard
- Central lubrication – standard
- Reliability built-in



## The double knotter function:

During the baling process, upper and lower twine strands are fed to the bale. These are tied together at the start (starting knot 1) and at the end (ending knot 2) of the bale that is being formed. The lower twine is guided through the needle by a tensioning system that

surrounds the bottom and the two ends of the bale. The upper twine is supplied to the bale directly by a tensioning system and does not run through the knotter like a Single knotter. This ensures that the machine can be driven with maximum baling force in all crops without dropping strings.

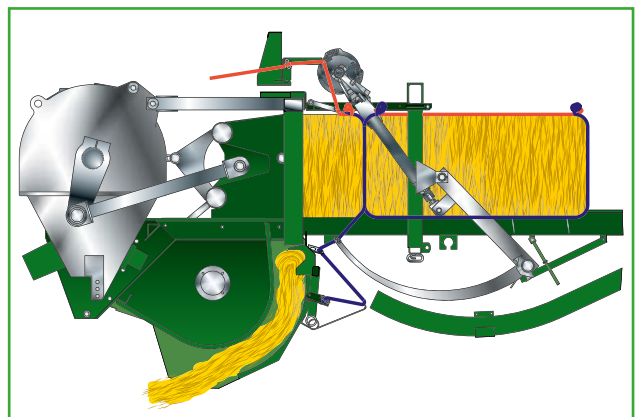
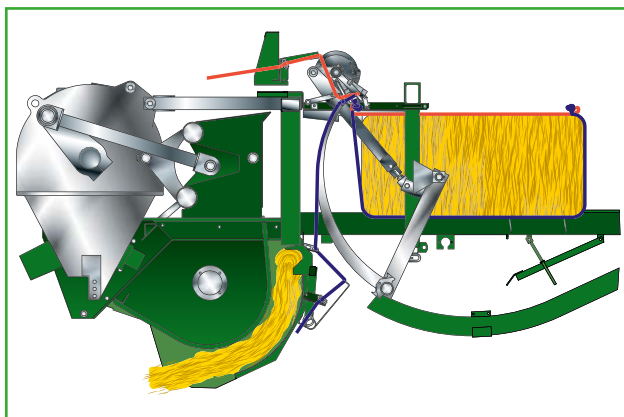



# Always a perfect knot

Highly compressed and well-tied bales are always guaranteed with the KRONE knotting system! This knotting technology operates with six knotters (four knotters in the BiG Pack 890) with absolute reliability. All KRONE large square balers with more than 700 mm (2'4") bale chamber height have double knotters as standard.



The BiG Pack 1270 is available with single knotters or optionally with double knotters.



## For long working days::

Each twine box on either side of the machine holds 16 balls of twine. Those 32 balls of twine will tie more than 900 bales without the need for a recharge. The dust-tight twine boxes fold up to give access to the service points.

## Compressed air cleaning:

The air pipes are arranged so that the entire knotter area is kept clean. Compressed air cleaning guarantees consistently high reliability of the knotters – even under extreme operating conditions.



## Compressor onboard:

Tractors that do not have a compressed air systems, with KRONE no worries as you will get an onboard compressor as standard equipment. Compressed air keeps the knotters clean in all conditions, in all countries. Plus it has a quick coupler so you can blow down the machine yourself after the days work.

## How about some extra twine?

Extra twine boxes are available for all BiG Pack square balers. The two boxes are mounted at the rear and hold 12 balls of twine or 10 balls and a toolbox.





# Control units

Putting you in control

- Colour high-resolution touchscreen
- Specified to ISOBUS standards, the CCI Terminal operates on all KRONE machines that are ISOBUS compatible plus on third-party ISOBUS machines.
- CCI and ICAN: The CCI Terminal offers a range of applications in addition to operating the machine from here.
- If KRONE BiG Pack is operated by an ISOBUS tractor, you can control it from the existing tractor terminal.



## Delta Terminal

With the Delta Terminal, KRONE offers a convenient display that makes it easy to control and monitor the attached KRONE machine. The easy-to-read colour touchscreen gives the operator a full overview of all machine functions. In addition to that, the device is able to operate the machine on the basis of tractor data – provided this is specified accordingly – for example to automatically lock the steered axle when the combination reverses.



# Towards a digital future

With the ISOBUS BiG Pack, KRONE customers can already make a huge step towards a digital future today. Yet it's up to you how many steps you want to take at a time. The KRONE Delta terminal is extremely easy to operate and offers a colour touchscreen, which makes all machine data readily viewable. The inclusion of the ISOBUS CCI Terminal in your order opens up virtually unlimited potential.



## CCI Terminal

The ISOBUS CCI Terminal is your admission ticket to the digital data world. For example, you can send a specific job from your office PC directly to the terminal. The field navigation system then steers the operator reliably to the field, where he starts the job from the Task Manager and the system starts collecting data. At the end of the job, he sends the data to the office PC via the Internet or saves it on a USB drive. The data can then be fed into a farm management software system for processing. Then simply watch the invoice leaving the printer or view all bales in their specific field locations. This is what you can get from a CCI Terminal in appropriate specification. For more information, ask for our ICAN brochure.



## ISOBUS tractor terminal

All ISOBUS machines from KRONE can be operated from an existing ISOBUS tractor terminal. Simply connect the baler to the tractor terminal and use the same familiar interface. In addition, control units such as the WTK joystick can bring further ease of operation, depending on tractor specification.



# The running gear

Field to field, quickly and efficiently



- Available in 60 km/h (38 mph) format
- Spring-loaded tandem axle with or without caster steer axle for effective sward protection
- High-float tyres reduce compaction



## Sure-footed:

In storage position the machine is set down on a hydraulic height-adjustable parking jack. The hydraulic parking jack is available as standard for the BiG Pack 1290 HDP and BP 4x4. It is optional for all other balers.



## Suitable for all tractors:

The V-shaped drawbar is sturdy, adjustable in height and highly maneuverable when driving around the tightest corners. The PTO shaft is supported by an intermediate bearing position between the baler and the tractor providing a noticeably quiet, smooth operation of the shaft.



## As an alternative:

Further flexibility in tractor mounting is provided with a drawbar ball (K 80 system) coupling system. Whether using this system or the standard drawbar mounting system, the KRONE BiG Pack balers are designed to fit all makes of tractors.





# Time is money

Constantly improving cost efficiency and output! This task has the highest priority at KRONE. KRONE BiG Pack large square balers are mostly used by contractors and must be frequently moved from field to field. The ability to do this in a timely, safe manner is highly dependent on the running gear of the baler. Time is money and transporting at maximum speed is an important factor. The axles of the KRONE BiG Pack balers is rated at 50 km/h (31 mph) allowing operators the maximum, safe transport speed.



## HighSpeed – uneven roads:

With the tandem axle as a steerable unit the BiG Pack can be safely towed up to 50 km/h (31 mph). You master every curve with rear wheel steering. Whether in the field or in transport there is no tire scrubbing. For further operating convenience, the steering axle is brought hydraulically into mid-position and locked for reversing. The sprung steering axle unit can be equipped with the larger 22.5" tires.

## The single axle is standard equipment except for the BiG Pack 1290 HDP.

This feature includes a 40 km/h (25 mph) rating and large volume tires (except for the BiG Pack 1290 HDP). There are optional tires from 700/45-22.5/12PR up to 800/40 R26.5 according to machine type.

## The tandem axle with a parabolic sprung boogie:

The large swing distance gives advantages when in transportation and also reduces the ground pressure as it transmits uniform pressure onto the ground.

## It is your option:

The Boogie axle is available in two versions – either as rigid or caster steer axle with locking ram to lock it in its middle position. Both versions are approved for 60 km/h (38 mph) provided they are specified with appropriate tires.







# BiG Pack 890, 1270, 1290

Your key to success

- Active pick-up: The camless pick-up with powered feed roller
- The variable fill system
- Double knotters on 700 mm (2'4") bale chamber height as standard equipment
- Compressed air knotter cleaning
- Funnel-shaped bale chamber for higher baling density



### BiG Pack 890 VFS (XC):

Standard equipment is four double knotters, seven spring loaded hay dogs in the bale chamber and three hydraulic cylinders for the upper and side bale chamber doors. Because of the narrow chamber width, the X-Cut cutting system has a maximum of 16 knives.



### BiG Pack 1270 VFS (XC):

For highest baling densities this machine has seven spring loaded hay dogs in the bale chamber and four hydraulic cylinders for the upper and side bale chamber doors. It is possible to choose between single and double knotters.



### BiG Pack 1290 VFS (XC):

This machine has nine spring loaded hay dogs in the bale chamber and four large hydraulic cylinders for the upper and the two side bale chamber doors. The six double knotters are standard.



# Balers that do not compromise

The KRONE large square balers are classic examples of exceptional baling density, output and comfort. With their different chamber dimensions and many unique features, the BiG Pack 890 VFS (XC), 1270 VFS (XC) and 1290 VFS (XC) work in worldwide conditions with absolute success in straw, hay and other crops. With a KRONE large square baler you have the right machine in your fleet: Reliable, powerful and designed for versatile application. Your customers enjoy well-shaped bales and you enjoy satisfied customers.



## Machine options

### 1. Everything under control:

You can opt for a reverse-drive CCTV system that comprises a camera and a colour screen, which has a second port for a second camera. The CCI Terminal is also compatible with the camera.

### 2. Documentation

Documentation is becoming more and more important in modern farming, especially when the bales are produced for customers abroad. To cater for these situations, KRONE offers a bale tagging system that is available for all KRONE big balers and that automatically attaches an RFID chip to every finished bale. The chip contains all important information, which can be read with a scanner as often as required.

### 3. Harvesting quality:

The optional moisture sensor updates the operator on the current crop condition, displaying the information on the cab-based monitor. The system gives an alarm whenever a preset parameter is exceeded.

### 4. The precise weight

Would you like to know whether the bale weight meets the requirements of your customers? Then, the optional bale chute with integral weighing system is just the right technology for you. The terminal now displays not only the weight of every single bale but also the total weight of the finished baling job.

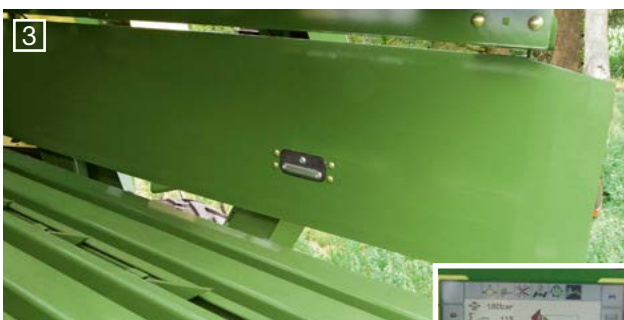

# KRONE-MultiBale

Small bales within a large bale



- Up to 9 single bales in one large bale
- Bale lengths as required: from 0.30 m to 1.35 m (1' to 4'5")
- Simple handling with small bales
- BiG performance in the field: Easy handling on the farm



## Large becomes small

During operation the driver sets the required small bale on the control panel in the tractor cab. The bale length of the small bales can be set continuously from 45 cm (1'6") to 135 cm (4'5") on the control terminal of the

Comfort controller. The smaller single bales are bound by two strings, the entire bale by four strings. Naturally you can also work with conventional full size single bales, all tied with six strings.

Up to nine bales in one!

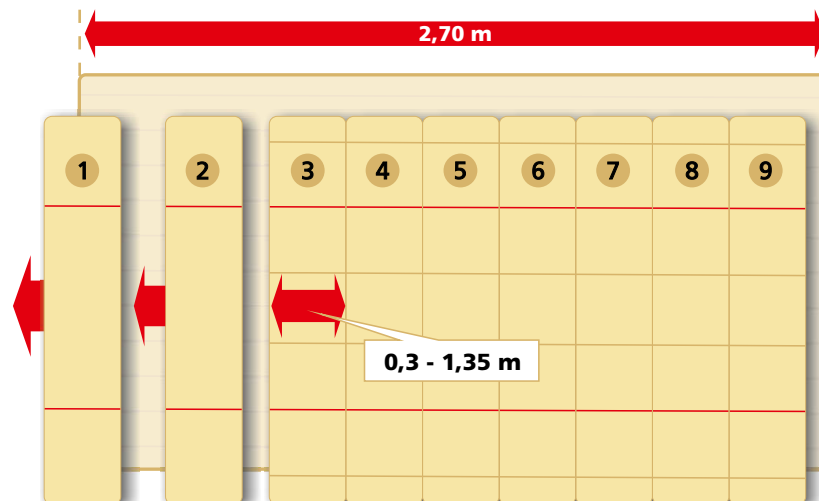



# MultiBale – An EXCLUSIVE from KRONE



Up to nine single bales in one large bale. The award-winning MultiBale method simplifies handling. The length of the small bales can be adjusted from 30 cm (1') to 135 cm (4'5"). In operating the MultiBale a conventional large bale, up to 270 cm (8'10") long can be baled, which contains up to nine smaller bales. The MultiBale system provides its owner with access to a wider customer base and outstanding flexibility in bale packages.

## An operator's dream come true from KRONE:

The MultiBale system for KRONE BiG Pack large square baler 1270 VFS (XC) with double knotters and Comfort controller. With MultiBale the field is quickly baled and large bales made of small bales can be delivered to the customer. The length of the entire bale as well as the number of small bales can be set conveniently and simply on the terminal in the tractor cab. The MultiBale system has become a very popular model straight after its introduction to the market, because it has filled a significant need and wish of contractors and farmers. To make small conventional bales from a high output large square baler, to reduce costs, time and handling.

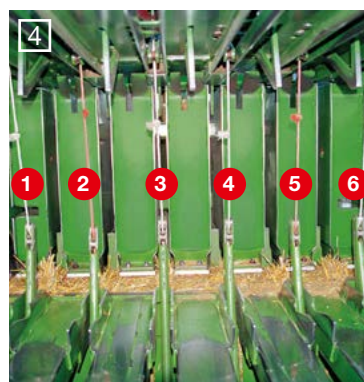
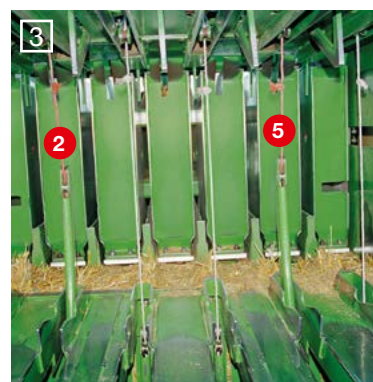
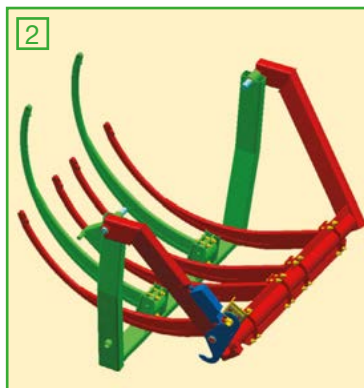
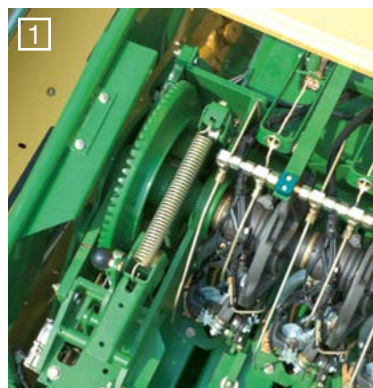

### 1. Two or six knots:

The twin string guide of the upper and lower needles the double knotter makes it possible. The knotter will only work when it is fed with twine. In forming multiple bales the needles of string 1, 3, 4, 6 are not swung into the knotter system therefore it will not tie off the strings, but when a needle is present in knotter 2 & 5 it will tie off a knot. Means when no needle is in the knotter it is inactive.

### 2. The KRONE MultiBale capability is achieved with a divided needle yoke:

The two needle yokes are coupled or uncoupled by a controlled latch. This can be activated and monitored from the tractor seat.

### 3. Two strings for the small bale:

Each small bale is tied by two knotters. The two strings securely hold the small bales in shape for further transport and distribution.

### 4. Six twines for the entire bale:

With the MultiBale, large bales up to 270 cm (8'10") long can also be baled. Both needle yokes are coupled to the knotters in this setting and the knotters are synchronized to tie all the knotters at the same time.



# BiG Pack 1290 HDP

(High-Density-Press)



- Highest Baling Density – Up to 25% higher bale weights
- Extended bale chamber
- Strong direct drives
- 6 double knotters for standard twine
- X-Cut cutting system optional

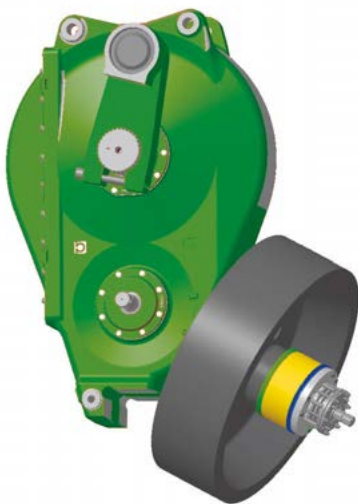

### Flying high

The huge bevel gearbox in combination with the nearly 600 kg (1,323 lbs) flywheel can cope with more than 830 kW/1100 hp and efficiently absorbs peak loads on the plunger. The slip clutch is arranged in front of the flywheel to protect the driveline on the tractor while a cam clutch protects the machine's driveline.

### Starting off easy

KRONE offers a hydraulic starting aid for its 1290 HDP and 4x4 BiG Pack big balers. A hydromotor accelerates the almost 600 kg (1,323 lbs) flywheel to more than 300 rpm before the tractor pto is engaged – obviously, from the cab terminal.





# Bales like bricks

HDP (High Density Press) is the all-new, innovative solution from KRONE for high-density bales. The KRONE BiG Pack 1290 HDP with the chamber

dimensions of 120 x 90 cm (3'11" x 2'11") and an extended bale chamber opens up new bale packaging possibilities with its baling density. In comparison to conventional large square balers, the large bales of the HDP achieve an increased bale weight up to 25%.



## The extended bale chamber:

Straw bales 500 kg (1,102 lbs) in weight, 235 cm (7'9") long. The BiG Packs 1290 HDP have proven this result several times in straw. The strengthened bale chamber with a funnel shape, extended by 80 cm (2'7.5"), insures an increased bale density up to 25 % higher than a typical bale of the same dimensions.

## For highest density:

The plunger is designed and reinforced for maximum strength to withstand the highest loads. Six hydraulic cylinders generate the force on the side bale chamber doors allowing the operator to make rock solid large bales.



## Operator convenience:

The BiG Pack 1290 HDP (XC) is equipped with a standard roller ramp. The chute may be fitted with an optional and integral weighing system.

## X-Cut:

The demand for cut straw is increasing. One more reason for optional equipment on the BiG Pack 1290 HDP X-Cut system with the proven 26-knife cutter the number of knives can be selected from 0 to 26. With the knives in you will achieve higher bale densities and finer cutting which is wish for pig or poultry farmers for easier distributing.



# BiG Pack 1290 HDP (XC)

Up to 25 % more weight per bale

- Fewer bales per acre
- Faster baling of the field
- Lower transportation costs
- Up to 5 tons higher payload per truck
- Reduction of labor costs
- Smaller storage space needed



## Quick payback

Harvesting a crop that yields 4 tons of straw per hectare and producing 500 kg bales rather than 400 kg from a traditional big baler, you will reduce the number of bales to be collected by two per hectare. Although

the machine uses higher quality twine (KRONE recommends the 110 m/kg KRONE Excellent Twine HDP), the cost for twine material drop by up to 25 %, courtesy of the higher baling density.







**Economy:**

Operating profits and cost effectiveness of straw baling depends very much upon the baling, transportation and storage costs. KRONE has the answer with the HDP system. With up to 25 % higher bale density you reduce the production costs per ton during baling and the storage cost per ton after baling, and transportation costs per ton during distribution. The professional marketing of straw now has an increased profit potential. The KRONE large square baler HDP 1290 (XC) can insure of your success. Working hard or working smart!



**Highest tonnage on the smallest area:**

Locations and the right areas for storage facilities are hard to find plus getting very expensive these are decisive factors for making profit in professional marketing of straw. Because of the high baling density you save space with the bales from a BiG Pack 1290 HDP. The uniform and sharp-edged bales can be stacked especially well. An additional benefit is that the rock solid bales are relatively insensitive to the influence of moisture and rain.



**With full load:**

Rising fuel prices and highway toll charges increase freight costs dramatically. For this reason it is very important that a truck with a permissible gross weight of 40 t is fully loaded, as the costs remain the same even if the payload is not fully utilized. Tests have shown that up to 5 tons more can be loaded with the HDP bales. The calculation is quite simple: At an unloaded weight of the truck of 15.5 t you come to 24.5 tons load with HDP bales 500 kg (1,102 lbs) in weight, to only 19.5 tons with bales 400 kg (882 lbs) in weight.





# BiG Pack 4 x 4

The world's biggest square bales

- A redesigned pick-up, a larger packer space and a packer with up to 50% higher throughput
- Fewer bales per hectare
- Time saving during bale collection
- Reduced costs
- Double knotter for 130 m/kg standard twine
- Optional X-Cut cutting system



## BiG Pack 4 x 4

### The name spells sheer efficiency

KRONE BiG Pack 4 x 4 – that's the formula for a huge 4ft x 4ft baling chamber and a host of innovative details. The bigger pre-chamber and the completely redesigned EasyFlow pick-up with active drive accelerating roller results in throughputs that are unprecedented. The massive, high-momentum flywheel and equally massive gearbox compress the material up to 38 times per minute, making rock-hard bales – powerfully and gently at the same time. KRONE BiG Pack is the formula for sheer efficiency.





# The world's biggest square bales

KRONE BiG Pack 4 x 4 is the ideal machine to get fields cleared quickly and efficiently.

A 4ft x 4ft baling chamber produces bales of 3.20 m (10'6") in length and 5 m<sup>3</sup> in volume – there is no other machine that can match this. These massive bales suit farming needs as well as industrial applications.



## The secret lies in the details

The new KRONE BiG Pack 4 x 4 HighSpeed delivers dramatically higher throughputs than its predecessor. The secret behind this is the 36 % larger feed chamber with a brand new VFS Variable Filling System. The four packer arms and the feeder arm are now equipped with more tines than ever before.

## Good technology is surpassed by better technology

KRONE's longstanding and well-proven EasyFlow pick-up receives an active-drive feed roller to boost its performance on BiG Pack 4x4. This roller feeds the material actively into the machine – just like on the BiG X forage harvester. The generously sized roller crop guide mounts at a large ground clearance, eliminating the risk of material building up on either end of the pick-up when working in extremely large windrows.



## Good lubrication saves on repairs

Therefore BiG Pack 4x4 (and every KRONE BiG Pack) has all its grease points taken care of by an auto lubrication system. The only grease points left for manual attention are those on the drive shafts. The reservoir is in easy reach on the yoke on the right side of the machine.





Citation from a driving impression of the German agricultural machinery magazine **profi**:

Krone BiG Pack 1290 HDP:

## Rock-hard bales

HDP stands for High Density and is Krone's magic formula for baling big, high-density bales. **profi** took the BiG Pack 1290 HDP model to the field for an exclusive driving impression to find out about the technology the North German manufacturer uses to advance into dimensions of baling that seemed inconceivable up to now. (...) Our highly condensed conclusion: The new KRONE BiG Pack HDP is a very intriguing machine for those who are into professional straw harvesting and transportation. After all, a 25-30% increase in bale density is a word (and obviously means fewer bales, too). With this in mind, the 25% price premium over a regular BiG Pack model as well as the higher input requirement are really "peanuts" in view of the fact that higher-density bales allow for added truck loads of 5 to 6 tonnes – quite an advantage in times of toll roads and rising diesel fuel prices.

Citation from **profi** 10/2005 pp30



Donald Shiermeier, Fairfield, Idaho (USA)

## "BiG Pack with variable feed system"

I like the feeding system on the KRONE baler. It seems to be more gentle on the hay. The maintenance part of the KRONE baler is very attractive as well; the auto lube system greases everything but the drivelines. It's also a very smooth running baler, which equates to less wear.







Ton Verschoor, NL

## High-density and just right for transport

“As a straw harvesting and transport specialist we have relied on KRONE-BiG Pack HDP balers for a long time. We currently operate eleven BiG Pack 1290 HDP units. What we really like about these balers is the fact that they really produce high-density bales that will not lose their shapes. Our experience is that HDP bales are at least 30 percent heavier than those bales we produce with a regular KRONE

1290 baler. Now, loading 52 bales on one truck, we can use truck capacity to full potential, both as to weight and volume. This is a huge advantage as we transport straw down to Austria and Italy, covering distances as large as 600 km. Storage of HDP bales is also more efficient. When you stack 12 bales onto each other, the bale at the bottom carries a load of about 5,500 kg (12,125 lbs). This is no problem for a HDP bale, which is firm and solid throughout – in the middle, on the corners and along the edges. There is no fraying. Another important point is that all bales are absolutely identical in size. For example, in Southern Europe, straw bales are transported in 40-foot containers, which are unforgiving about varying bale sizes. If the bales differ in size, there is no chance to attain the target load. All this is no problem for KRONE HDP bales, which are all the same size. On balance, I’d say, contractors who also take care of the straw logistics will find a BiG Pack HDP is paying off quickly.”



# Technical Data



## BiG Pack

		BiG Pack HighSpeed 890	BiG Pack HighSpeed 890 XC	BiG Pack HighSpeed 1270	BiG Pack HighSpeed 1270 XC
Chamber width & height	approx. mm	800x900 (2'7.5" x 2'11")	800x900 (2'7.5" x 2'11")	1,200x700 (3'11" x 2'4")	1,200x700 (3'11" x 2'4")
Bale length	approx. mm	1,000 - 2,700 (3'3" - 8'10")	1,000 - 2,700 (3'3" - 8'10")	1,000 - 2,700 (3'3" - 8'10")	1,000 - 2,700 (3'3" - 8'10")
Power requirement	from kW/HP	90/122	95/130	93/127	100/136
Pick-up working width DIN	approx. mm	1,950 (6'5")	1,950 (6'5")	2,350 (7'9")	2,350 (7'9")
Length in transport position	approx. mm	7,930 (26')	7,930 (26')	7,930 (26')	7,930 (26')
Length in working position	approx. mm	9,180 (30'1")	9,180 (30'1")	9,180 (30'1")	9,180 (30'1")
Height	approx. mm	3,075 (10'1")	3,075 (10'1")	2,875 (9'5")	2,875 (9'5")
Width	approx. mm	2,550 (8'4")	2,550 (8'4")	2,995 (9'10")	2,995 (9'10")
Weight	approx. kg (lbs)	6,580 (14,506)	7,480 (16,490)	7,240 (15,961)	8,430 (18,585)
Tires single axle 40 km/h (25 mph)		710/45-22.5 162 A8	–	–	–
Tires tandem axle 50 km/h (31 mph)		500/500-17/14 PR 550/45 22.5 16 PR 620/40 R22.5 148 D	500/500-17/14 PR 550/45 22.5 16 PR 620/40 R22.5 148 D	– 550/45 22.5 16 PR 620/40 R22.5 148 D	– 550/45 22.5 16 PR 620/40 R22.5 148 D
Brakes*		2-circuit compressed air*	2-circuit compressed air*	2-circuit compressed air*	2-circuit compressed air*
String Storage	rolls	32	32	32	32
Single knotter		–	–	standard	standard
Double knotter		standard	standard	optional	optional
Knives max.		–	16	–	26
Minimum cutting length	mm	–	44 (1.7")	–	44 (1.7")
Stroke length	mm	750 (2'5.5")	750 (2'5.5")	750 (2'5.5")	750 (2'5.5")
Ram strokes	per minute	50	50	45	45
PTO shaft		Wide angle with overrun clutch	Wide angle with overrun clutch	Wide angle with overrun clutch	Wide angle with overrun clutch

All specifications, weights and dimensions do not necessarily comply with standard specifications and are therefore not binding.

\* Country-specific also available with hydraulic brakes

### Service is the first order at KRONE.

Our global distributors and dealers are trained regularly and informed about all innovations, maintenance and service matters. KRONE's international factory training and engineering team visits customers all over the world. They have one goal: to keep improving the most innovative baler in the world. WE LISTEN TO OUR CUSTOMERS. As a customer we know you won't tolerate downtime causing your harvesting train to stop. Every minute is important. KRONE operates a total of over 2,100 spare parts stores worldwide. Every dealer or distributor can be supplied with spare parts within hours, keeping you in the field. Look for the KRONE dealer or distributor in your area.



	BiG Pack HighSpeed 1290	BiG Pack HighSpeed 1290 XC	BiG Pack HighSpeed 1290 HDP	BiG Pack HighSpeed 1290 HDP XC	BiG Pack 4x4	BiG Pack 4x4 XC
	1,200x900 (3'11" x 2'11")	1,200x900 (3'11" x 2'11")	1,200x900 (3'11" x 2'11")	1,200x900 (3'11" x 2'11")	1,200x1,300 (3'11" x 4'3")	1,200x1,300 (3'11" x 4'3")
	1,000 - 2,700 (3'3" - 8'10")	1,000 - 2,700 (3'3" - 8'10")	1,000 - 3,200 (3'3" - 10'6")	1,000 - 3,200 (3'3" - 10'6")	1,000 - 3,200 (3'3" - 10'6")	1,000 - 3,200 (3'3" - 10'6")
	105/143	112/152	140/190	147/190	135/184	140/190
	2,350 (7'9")	2,350 (7'9")	2,350 (7'9")	2,350 (7'9")	2,350 (7'9")	2,350 (7'9")
	7,930 (26')	7,930 (26')	8,850 (29')	8,850 (29')	9,060 (29'9")	9,060 (29'9")
	9,180 (30'1")	9,180 (30'1")	9,940 (32'7")	9,940 (32'7")	10,850 (35'7")	10,850 (35'7")
	3,075 (10'1")	3,075 (10'1")	3,110 (10'2")	3,110 (10'2")	3,600 (11'10")	3,600 (11'10")
	2,995 (9'10")	2,995 (9'10")	2,995 (9'10")	2,995 (9'10")	2,995 (9'10")	2,995 (9'10")
	7,860 (17,328)	9,050 (19,952)	10,200 (22,487)	11,500 (25,353)	11,150 (24,581)	12,350 (27,227)
	-	-	-	-	-	-
	550/45 22.5 16 PR 620/40 R22.5 148 D	550/45 22.5 16 PR 620/40 R22.5 148 D	550/45 22.5 16 PR 620/40 R22.5 148 D	550/45 22.5 16 PR 620/40 R22.5 148 D	620/40 R22.5 148 D	620/40 R22.5 148 D
	2-circuit compressed air*	2-circuit compressed air*	2-circuit compressed air*	2-circuit compressed air*	2-circuit compressed air*	2-circuit compressed air*
	32	32	32	32	32	32
	-	-	-	-	-	-
	standard	standard	standard	standard	standard	standard
	-	26	-	26	-	26
	-	44 (1.7")	-	44 (1.7")	-	44 (1.7")
	750 (2'5.5")	750 (2'5.5")	750 (2'5.5")	750 (2'5.5")	800 (2'7.5")	800 (2'7.5")
	45	45	45	45	38	38
	Wide angle with overrun clutch	Wide angle with overrun clutch	Wide angle with overrun clutch	Wide angle with overrun clutch	Wide angle with overrun clutch	Wide angle with overrun clutch

### The beauty of a low price fades when low parts quality stops your harvest chain.

Low parts prices are a strong temptation. The convincing story about good quality from the spare parts dealer around the corner often proves to be a fairy tale. Reports in professional journals have proven that quality tested by the manufacturer lasts longer and functions more safely. Do not compromise. Trust KRONE original spare parts.



# KRONE Internet



Discover the world at KRONE and browse through our website pages to find facts and figures and also new developments plus a wide range of services. Explore our website and find out how versatile the KRONE world is.



## News

Click here to find up-to-the minute information about KRONE – from new product presentations to show reviews. Here you are at the pulse of KRONE life.



## Products

Find extensive information on our full product range. This section holds everything you need – from video clips to manuals.



## Sales organisation

Here you find a distributor in Japan as well as your local KRONE dealer who will be pleased to support you. This is where you find your KRONE partner who will be pleased to assist you.



## Jobs

Would you like to join our company? KRONE is often looking for diligent and motivated staff to work at our farm machinery factory as well as at our commercial trailer production plant. So, this section is always worth a visit.



## Media center

The KRONE 'database' holds thousands of documents, pictures, test reports and much more. Here you find very detailed information on KRONE products that are of special interest to you.



## Events

Are you in for a KRONE live experience? Check out for KRONE events and look at a machine on show or watch it during a demonstration. After all, there is little that is more effective than a hands-on experience.



## Service

Here you find all the service information you require – from a point of contact at the factory to finance schemes for your KRONE machine as well as training schemes for staff and users.



## Download Center

Are you looking for a KRONE calendar for your desktop or a smart picture for your presentation? Here, at the KRONE download center, you will find plenty of useful material for a wide range of projects.



## Used Machinery

KRONE often has a wide range of demonstration or exhibit machinery on offer. This is a good site to find your KRONE machine. Then contact your local KRONE dealer to arrange the details of a potential purchase.



## Parts

24/7... This service gives you the opportunity to find your KRONE part at any time and without waiting. The KRONE Agroparts Portal has an article number and exact description for every part. You can order the part instantly at your local KRONE dealer by sending an e-mail to Agroparts.



## KRONE shop

Are you looking for a gift or are you a collector of farm models? Then you should definitely shop around at our KRONE shop. We take your orders at any time of the day.

Your KRONE dealer

## Maschinenfabrik Bernard KRONE GmbH

Heinrich-Krone-Straße 10  
D-48480 Spelle

Telefon: +49 (0) 5977.935-0  
Telefax: +49 (0) 5977.935-339

info.ldm@krone.de  
www.krone.de