



5125G

HD

DEUTZ



FAHR



THE NEW 5125G

HD

The all rounder from Deutz-Fahr

For efficient work with tractors - working, driving and operating comfort is as important as versatility.

Agriculture, should it be, feed cultivation, livestock, viticulture, horticulture or municipal uses – the range of applications are getting bigger and bigger while working days are getting longer and longer. Only when a tractor is 100% compatible with the task profile of the farming enterprise, it is then possible to work with economic success.

Deutz-Fahr has developed the 5125G Heavy Duty Series for this purpose. 126 max horsepower is available powered by the Deutz-Fahr FARMotion common rail engine. This model is distinguished by their versatility, technology and maximum comfort. The high-comfort air-conditioned cab is placed on Hydro-Silent blocks where up to 40% less noise and vibration in the cab are the result.

A new heavy duty front axle equipped with internal wet disc brakes provides higher load ratings, driving comfort and safety especially when using a front end loader. Combine this with the wet clutch heavy duty semi powershift transmission you can ensure to get smooth shuttle movements and the right speed.

Hydraulic flow is becoming a higher requirement with many implements in today's era and fitted to the Deutz-Fahr 5125G HD tractor is the "ON DEMAND" 90 l/min hydraulic system. This hydraulic system is standard with three sets of rear remotes with flow control/detent and float functionality.

Whatever your requirements are for an all-rounder tractor, the Deutz-Fahr 5125G HD will meet them.



FEATURES

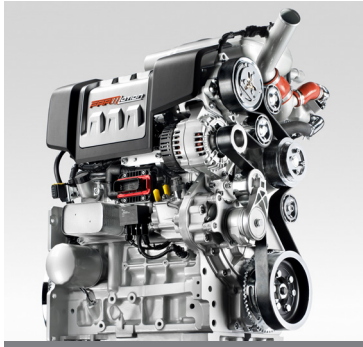

**DEUTZ-FAHR 126HP
FARMotion ENGINE**

The heart of the 5125G HD tractor is a 3820cc 4 cylinder turbo intercooled common rail diesel engine developing 126 max hp and 550Nm torque.



**ENGINE SPEED
PROGRAMMING**

The engine speed programming feature allow you to set and retrieve 2 engine rpms. This feature improves fuel efficiency compared to a mechanical throttle engine.

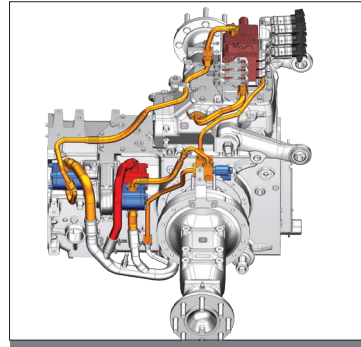

**ON DEMAND 90L/MIN
HYDRAULIC SYSTEM**

Engaging a button inside the cabin activates the on demand 90 l/min hydraulic system. This system engages a secondary pump to increase hydraulic flow rates to the rear remotes and front end loader.



**SENSE CLUTCH
POWER SHUTTLE**

A heavy duty wet clutch powershuttle with a 5 speed modulation control allows to guarantee smooth directional changes when shuttling forward and reverse.



STOP & GO

It's in the words really – when system engaged you can drive like an auto car by pressing your foot only on the brake pedal to STOP and releasing to GO.



**60/60 40KM
ECO GEARBOX**

Easy to use semi powershift transmission fitted with a speed matching 3 speed powershift. This gives you plenty of gear options from 230 m/hr to 40km at a reduced engine rpm.

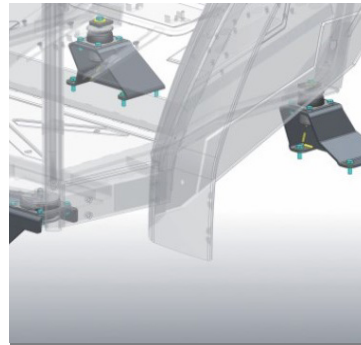

**HYDRO SILENT BLOCK
CAB SUSPENSION**

Cab vibration is reduced up to 40% thanks to hydro silent block cab suspension. This gives the operator a smooth ride over the paddock and increases comfort.



**HI VISIBILITY
GLASS ROOF**

A wide glass sunroof is fitted as standard to allow full upward vision when using a front end loader allowing the operator not to get a sore neck when loading hay.



SDD STEERING

SDD means steering double displacement. When engaged steering revolutions from lock to lock is 2.2 turns compared to 4.5 when disengaged. Great for loader work!



**FOUR WHEEL
WET DISC BRAKES**

Working in hilly terrain you need to be safe. The four wheel braking system on the 5125G HD is fitted with four independent wet disc brakes to give optimum stopping power.



ELECTRONIC LINKAGE

Simple and easy to use is the electronic lift. All position, draft, height and speed settings are adjusted via a dial. Standard fitment with this feature is the fender external raise and lower controls.



**AGROLIFT 3840
FRONT END LOADER**

A loader fitted with what you need – level lift, Euro II Quick Detach, soft ride boom suspension, 3rd function, integrated joystick control and heavy duty construction.

TECHNICAL DATA		5125G HD
ENGINE		
Emissions		Tier4i
Manufacturer		Deutz-Fahr FARMotion
Cylinders/Displacement/Valves	n°/cm³/n°	4/3849/2
Common rail	bar	2000
Turbo intercooler		•
Maximum power (ECE R 120) at 2000 rpm	kW/HP	94/126
Maximum torque at 1600 rpm	Nm	500
Torque rise	%	31
Engine speed programming		•
Engine speed settings		2
Exhaust gas emissions treatment system		DOC / exEGR
Fuel tank capacity	litres	150
SHUTTLE		
Wet clutch power shuttle		•
Stop & Go system		•
Sense clutch modulation system		•
POWERSHIFT GEAR-BOX		
5-speed gearbox		•
Speeds with underdrive and creeper	n°	60 + 60
Powershift gear number	n°	3
Comfort clutch		•
Speed matching		•
Min speed	m/h	230
Max speed	km/h	40 Eco
REAR PTO		
Electrohydraulically operated		•
540/540ECO/1000/1000ECO PTO		•
Auto PTO		•
FRONT PTO		
1000 PTO		○
FRONT AND REAR AXLE		
Electrohydraulically operated 4WD		•
Electrohydraulically operated differential lock		•
BRAKES AND STEERING		
4-wheel braking		•
Mechanical parking brake		•
Hydrostatic steering with independent pump		•
SDD system		•
HITCH		
Electronic rear hitch		•
Rear lift capacity (std)	kg	5410
Front hitch		○
Front lift capacity	kg	1850
HYDRAULIC SYSTEM		
On Demand hydraulic system		•
Hydraulic pump flow rate	l/min	90
Steering pump flow rate	l/min	40
Rear auxiliary spool valves		6 STD / 6 + 2 OPT
Spool valve functionality		3 Float / Detent with flow control
CAB		
Air conditioning		•
High-visibility glass roof		•
Driver seat with air suspension		•
Passenger seat		○
Hydro silent block cab suspension		•
DIMENSIONS AND WEIGHTS		
Standard tyre equipment		540/65R38 Rear - 440/65R28 Front
Max length with lift linkage	mm	4265
Width - min/max	mm	2209 / 2609
Wheelbase (4WD)	mm	2400
Front track width - min/max	mm	1690 / 1870
Rear track width - min/max	mm	1708 / 1796
Max height over cab	mm	2730
Weight with cab	kg	4400
Maximum permissible load	kg	7500

STD • OPT ○ Not available -

Technical specifications and images are purely indicative. DEUTZ-FAHR reserves the right to make updates at any time and without prior notice. For standard equipment and options refer to the current price list and ask your local dealer for details.

FEB2020