



- U.S.A. : **KUBOTA TRACTOR CORPORATION**
1000 Kubota Drive, Grapevine, TX 76051
Telephone : 888-4KUBOTA
- Canada : **KUBOTA CANADA LTD.**
5900 14th Avenue, Markham, Ontario, L3S 4K4, Canada
Telephone : (905)294-7477
- France : **KUBOTA EUROPE S.A.S**
19-25, Rue Jules Verceyruysse, Z.I. BP88, 95101 Argenteuil Cedex, France
Telephone : (33)1-3426-3434
- Italy : **KUBOTA EUROPE S.A.S Italy Branch**
Via Grandi, 29 20068 Peschiera Borrome (MI) Italy
Telephone : (39)02-51650377
- Germany : **KUBOTA (DEUTSCHLAND) GmbH**
Senefelder Str. 3-5 63110 Rodgau /Nieder-Roden, Germany
Telephone : (49)6106-873-0
- U.K. : **KUBOTA (U.K.) LTD.**
Dormer Road, Thame, Oxfordshire, OX9 3UN, U.K.
Telephone : (44)1844-214500
- Spain : **KUBOTA ESPAÑA S.A.**
Avenida Recomba No.5, Poligno Industrial la Laguna, Leganes, 28914 (Madrid) Spain
Telephone : (34)91-508-6442
- Australia : **KUBOTA AUSTRALIA PTY LTD.**
25-29 Permas Way, Truganina, VIC 3029, Australia
Telephone : (61)-3-9394-4400
- Malaysia : **SIME KUBOTA SDN. BHD.**
No.3 Jalan Sepadu 25/123 Taman Perindustrian Axis,
Seksyen 25, 40400 Shah Alam, Selangor Darul Ehsan Malaysia
Telephone : (60)3-736-1388
- Philippines: **KUBOTA PHILIPPINES, INC.**
232 Quirino Highway, Baesa, Quezon City 1106, Philippines
Telephone : (63)2-422-3500
- Taiwan : **SHIN TAIWAN AGRICULTURAL MACHINERY CO., LTD.**
16, Fengping 2nd Rd, Taliiao Shiang Kaohsiung 83107, Taiwan R.O.C.
Telephone : (886)7-702-2333
- Indonesia : **PT KUBOTA MACHINERY INDONESIA**
Tower A at EightyEight@Kasablanka Lantai 16
Jalan Raya Casablanka Kav. 88, Jakarta 12870 Indonesia
Telephone : (62)-21-29568-720
- Thailand : **SIAM KUBOTA CORPORATION CO., LTD.**
101/19-24 Moo 20, Navanakorn Industrial Estate, Tambon Khlongnueng, Amphur Khlongluang,
Pathumthani 12120, THAILAND
Telephone : (66)2-909-0300
- Korea : **KUBOTA KOREA CO., LTD.**
41-27, Jayumuyeok-gil, Baeksan-myeon, Gimje-si, Jeollabuk-do, Korea
Telephone : (82)-63-544-5822
- India : **KUBOTA AGRICULTURAL MACHINERY INDIA PVT. LTD.**
No.15, Medavakkam Road, Sholinganallur, Chennai-600119, T.N., India
Telephone : (91)44-6104-1500
- Vietnam : **KUBOTA VIETNAM CO., LTD.**
Lot B-3A2-CN, My Phuoc 3 Industrial Park, Thoi Hoa Ward, Ben Cat Town, Binh Duong Province, Vietnam
Telephone : (84)-274-3577-507

KUBOTA Corporation

English (Australia)
Code No. 3B693-9971-1

OPERATOR'S MANUAL

KUBOTA TRACTOR

MODELS **M5091**
M5111



1MHJD00001A01

M
5
0
9
1
·
M
5
1
1
1

READ AND SAVE THIS MANUAL

ABBREVIATION LIST

Abbreviations	Definitions
2WD	2 Wheel Drive
4WD	4 Wheel Drive
API	American Petroleum Institute
ASABE	American Society of Agricultural and Biological Engineers, USA
ASTM	American Society for Testing and Materials, USA
DIN	Deutsches Institut für Normung, GERMANY
DEF	Diesel Exhaust Fluid
DPF	Diesel Particulate Filter
DT	Dual Traction [4WD]
fpm	Feet Per Minute
GST	Glide Shift Transmission
Hi-Lo	High Speed-Low Speed
HST	Hydrostatic Transmission
m/s	Meters Per Second
PTO	Power Take Off
RH/LH	Right-hand and left-hand sides are determined by facing in the direction of forward travel
ROPS	Roll-Over Protective Structures
rpm	Revolutions Per Minute
r/s	Revolutions Per Second
SAE	Society of Automotive Engineers, USA

KUBOTA Corporation is ...

Since its inception in 1890, KUBOTA Corporation has grown to rank as one of the major firms in Japan.

To achieve this status, the company has through the years diversified the range of its products and services to a remarkable extent. 30 plants and 35,000 employees produce over 1,000 different items, large and small.

All these products and all the services which accompany them, however, are unified by one central commitment. Kubota makes products which, taken on a national scale, are basic necessities. Products which are indispensable. Products which are intended to help individuals and nations fulfill the potential inherent in their environment. Kubota is the basic necessities giant.

This potential includes water supply, food from the soil and from the sea, industrial development, architecture and construction, and transportation.

Thousands of people depend on Kubota's know-how, technology, experience and customer service. You too can depend on Kubota.

UNIVERSAL SYMBOLS

As a guide to the operation of your tractor, various universal symbols have been utilized on the instruments and controls. The symbols are shown below with an indication of their meaning.

■ General

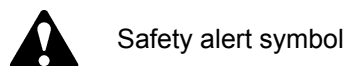

Safety alert symbol



Master system warning



Fast



Slow



Creep



Lock



On (engage)



Off (disengage)

■ Engine - related



Diesel fuel



Empty



Full



Hour meter / elapsed operating hours



Engine coolant - temperature



Engine intake / combustion air-filter



Engine oil pressure



Water separator



Engine - warning



n/min

Engine - rotational speed



n/min

Engine - rev limiter



rpm

Engine - constant RPM management



n/min

Engine - over speed



n/min

Engine - rpm memory A



n/min

Engine - rpm memory B



n/min

Engine - rpm increase



Engine - run



Engine - start



Engine - stop



Electrical power - accessories



Diesel preheat / glow plug
(low temperature start aid)



Regeneration



Regeneration inhibit





Regeneration (switch)

 Parked regeneration

■ **Vehicle body - related**

 4-wheel drive - on

 Operator presence control

 Clutch

 Brake

 Parking brake

 Differential lock

 Differential lock - automatic

 Steering wheel - tilt

 PTO - off (disengaged)

 PTO - on (engaged)

 PTO - 540 rpm

 PTO - 540E rpm

 PTO - 1000 rpm

 PTO - front

 PTO - rear

 PTO - ground

■ **Hydraulic - related**

 Draft control - shallow position

 Draft control - deep position

 Position control - raised position

 Position control - lowered position

 3 - point lowering speed control

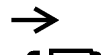
 Remote cylinder - retract

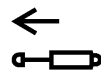
 Remote cylinder - extend

■ **Electric - related**

 Battery charging condition

 Headlight - low beam

 Headlight - high beam

 Turn signal

 Hazard warning lights

 Audible warning device

 Beacon light

 Windshield wiper

 Windshield wiper - intermittent

 Windshield washer

 Rear window defroster

FOREWORD

You are now the proud owner of a Kubota tractor. This tractor is a product of Kubota quality engineering and manufacturing. It is made of fine materials and under a rigid quality control system. It will give you long, satisfactory service. To obtain the best use of your tractor, please read this manual carefully. It will help you become familiar with the operation of the tractor and contains many helpful hints about tractor maintenance. It is Kubota's policy to utilize as quickly as possible every advance in our research. The immediate use of new techniques in the manufacture of products may cause some small parts of this manual to be outdated. Kubota distributors and dealers will have the most up-to-date information. Please do not hesitate to consult with them.

SAFETY FIRST

This symbol, the industry's safety alert symbol, is used throughout this manual and on labels on the machine itself to warn of the possibility of personal injury. Read these instructions carefully. It is essential that you read the instructions and safety regulations before you attempt to assemble or use this unit.



DANGER: Indicates an imminently hazardous situation which, if not avoided, will result in death or serious injury.



WARNING: Indicates a potentially hazardous situation which, if not avoided, could result in death or serious injury.



CAUTION: Indicates a potentially hazardous situation which, if not avoided, could result in minor or moderate injury.

IMPORTANT: Indicates that equipment or property damage could result if instructions are not followed.

NOTE: Gives helpful information.

CONTENTS

SAFE OPERATION	7
SERVICING OF TRACTOR	21
WARRANTY.....	22
SCRAPPING THE TRACTOR AND ITS PROCEDURE	22
SPECIFICATIONS	23
SPECIFICATION TABLE.....	23
TRAVELING SPEEDS	25
IMPLEMENT LIMITATIONS	27
IMPLEMENT SPECIFICATION TABLE.....	28
OVERVIEW OF TRACTOR PARTS	30
INSTRUMENT PANEL AND CONTROLS	32
SWITCHES AND HAND CONTROLS	32
INSTRUMENT PANEL.....	33
FOOT AND HAND CONTROLS	34
PRE-OPERATION CHECK	35
DAILY CHECK	35
OPERATING THE ENGINE	36
EXHAUST AFTERTREATMENT DEVICES.....	36
DIESEL PARTICULATE FILTER (DPF) MUFFLER	36
1. Handling points.....	36
2. DPF regeneration process.....	37
3. Operating procedure for auto regeneration mode	38
3.1 PM warning level and required procedures.....	39
4. Operating procedure for regeneration inhibit mode.....	40
4.1 PM warning level and required procedures.....	41
5. Operating procedure for parked regeneration	42
6. Tips on diesel particulate filter (DPF) regeneration	43
STARTING THE ENGINE	43
1. Checking Easy Checker™ indicators	45
OPERATING THE ENGINE IN FREEZING CONDITIONS.....	46
1. Block heater (if equipped).....	46
STOPPING THE ENGINE.....	46
WARMING UP THE ENGINE	46
1. Warm-up and transmission fluid at low temperature range	46
JUMP STARTING	46
OPERATING THE TRACTOR	48
OPERATING NEW TRACTOR	48
1. Do not operate the tractor at full speed for the first 50 hours	48
2. Changing lubricating oil for new tractors	48
BOARDING AND LEAVING THE TRACTOR	48
STARTING THE TRACTOR.....	48
1. Operator's seat	49
1.1 Mechanical suspension seat	49
1.2 Air suspension seat (if equipped).....	50
2. Seat belt	50
3. Instructional seat (if equipped)	50
3.1 Precautions in using the instructional seat.....	51
4. Tilt steering adjustment.....	52

5. Light switch	53
6. Turn signal switch and hazard light switch	53
6.1 With trailer connector	54
7. Horn button	54
8. Brake pedals (right and left)	54
8.1 4WD braking system (4WD model)	55
9. Parking brake lever	55
10. Gear-locked parking brake lever	55
11. Clutch pedal	55
12. Travel speed control	57
13. Travel speed limiter	58
14. Main gear shift lever	58
15. Range gear shift lever	58
15.1 Creep speed	58
16. Shuttle shift lever	58
17. Dual speed shift switch (if equipped)	59
18. <i>Clutch-off</i> switch (if equipped)	59
19. 4WD switch	60
19.1 Front-wheel drive (4WD) usage	60
20. Hand throttle lever	60
21. Foot throttle	60
STOPPING THE TRACTOR	61
CHECK DURING DRIVING	61
1. Engine over-speed limiting indicator	61
2. Easy Checker™	61
3. Fuel gauge	62
4. Coolant temperature gauge	63
5. Tachometer	63
LCD MONITOR	63
1. Various setting mode	64
1.1 Clock setting	64
1.2 Setting the clock display ON/OFF	65
1.3 Setting the tire circumference	65
1.4 Setting the unit	66
1.5 Setting the PTO speed display	66
2. Performance monitor	68
ELECTRONIC ENGINE CONTROL	69
1. <i>RPM dual memory</i> setting	69
2. <i>Constant RPM Management</i> control	70
PARKING THE TRACTOR	71
OPERATING TECHNIQUES	72
1. Differential lock	72
2. Operating the tractor on a road	73
3. Operating on slopes and rough terrain	73
4. Transporting the tractor safely	74
5. Directions for the use of power steering	74
6. Trailer electrical outlet	74
PTO	75
PTO OPERATION	75
1. PTO clutch control switch	75
2. PTO clutch indicator	75
3. PTO rpm display	76
4. PTO shaft cover and shaft cap	76
PTO MODELS	76
1. PTO 540/540E rpm model	76
1.1 PTO gear shift lever	76
1.2 PTO speed limiter	77

2. Interchangeable PTO 540/1000 rpm model.....	77
2.1 1000 rpm PTO shaft.....	77
3-POINT HITCH AND DRAWBAR.....	78
THE 3-POINT HITCH SETUP.....	79
1. Selecting the holes of lower links.....	79
2. Adjusting lateral float.....	79
3. Selecting the top link mounting holes.....	79
4. Drawbar.....	80
5. Lifting rod (left).....	80
6. Lifting rod (right).....	80
7. Top link.....	80
8. Telescopic stabilizers.....	81
8.1 Telescopic lower links.....	81
9. Quick hitch - hook type (if equipped).....	81
9.1 Installing ball-joint to implement.....	82
9.2 Adjusting lower link width.....	82
9.3 Attaching implement to tractor.....	82
9.4 Detaching implement from tractor.....	83
DRAWBAR.....	83
1. Adjusting drawbar length.....	83
2. Swing drawbar.....	84
HYDRAULIC UNIT.....	85
3-POINT HITCH CONTROL SYSTEM.....	85
1. Position control.....	85
2. Draft control.....	85
3. Mixed control.....	85
4. Float control.....	86
5. 3-point hitch lowering speed knob.....	86
REMOTE HYDRAULIC CONTROL SYSTEM.....	86
1. Remote control valve.....	86
2. Remote control valve lever.....	87
3. Remote control valve coupler.....	87
4. Flow control valve (option).....	88
4.1 Adjusting the flow rate.....	88
4.2 Positions and advantages of the flow control valve.....	88
5. Hydraulic control unit use-reference chart.....	90
TIRES, WHEELS AND BALLAST.....	91
TIRES.....	91
1. Inflation pressure.....	91
2. Dual tires.....	91
WHEEL ADJUSTMENT.....	91
1. Front wheels-4WD.....	92
1.1 Front jack point.....	93
2. Rear wheels.....	94
2.1 Rear jack point.....	95
CAB OPERATION.....	96
CAB CLASSIFICATION AND MAINTENANCE.....	96
DOORS AND WINDOWS.....	96
1. Locking and unlocking the door.....	96
2. Opening the door.....	96
3. Rear window.....	97
4. Side window.....	97
5. Sunroof.....	97
6. Emergency exit.....	97
DOME LIGHT.....	97

WORK LIGHT	98
1. Work light switch.....	98
2. Front work light.....	98
3. Rear work light.....	98
WIPER	99
1. Front wiper and washer switch.....	99
2. Rear wiper and washer switch.....	99
3. Using the wipers in cold season	99
AIR CONDITIONER.....	99
1. Airflow.....	99
2. Air control vent.....	100
3. Control panel	100
3.1 Mode switch	100
3.2 Temperature control dial.....	101
3.3 Blower switch	101
3.4 Air conditioner switch	101
3.5 Recirculation or fresh air selection switch	101
4. Operation	101
4.1 Heating.....	101
4.2 Cooling or dehumidifying-heating.....	102
4.3 Defrosting or demisting	102
INSTALLING THE IMPLEMENT CONTROL BOX.....	103
ELECTRICAL OUTLET.....	103
BEACON LIGHT	103
MAINTENANCE.....	105
SERVICE INTERVALS.....	105
MAINTENANCE ITEMS CHART.....	106
LUBRICANTS, FUEL AND COOLANT	108
PERIODIC SERVICE	110
WASTE DISPOSAL	110
HOW TO OPEN THE HOOD	110
1. Hood.....	110
2. Side cover.....	110
DAILY CHECK	111
1. Walk around inspection	111
2. Checking and refueling.....	111
3. Checking water separator.....	112
4. Checking engine oil level.....	112
5. Checking transmission fluid level	112
6. Checking coolant level.....	113
7. Cleaning evacuator valve	113
8. Cleaning grill, radiator screen, oil cooler, fuel cooler, air conditioner condenser and battery mount.....	113
8.1 Detaching the panel	114
8.2 Sliding the air conditioner condenser	114
8.3 Cleaning	114
9. Checking DPF muffler.....	114
10. Checking brake pedal.....	115
11. Checking gear-locked parking brake	115
12. Checking parking brake.....	115
13. Checking gauges, meter and Easy Checker™	115
14. Checking headlight, turn signal light, hazard light, and so on	116
15. Checking seat belt	116
16. Checking movable parts	116
INITIAL 50 HOURS.....	116
1. Changing engine oil.....	116
2. Replacing engine oil filter	116

EVERY 50 HOURS	116
1. Checking engine start system	116
1.1 Preparation before testing	116
1.2 Testing switch for the shuttle shift lever	116
1.3 Testing switch for PTO clutch control switch	116
2. Checking operator presence control (OPC) system	117
3. Checking wheel bolt torque	117
4. Checking tie-rod dust cover	117
EVERY 100 HOURS	117
1. Lubricating grease fittings	117
2. Cleaning air cleaner primary element	119
3. Adjusting fan belt tension	119
4. Adjusting brake pedal	120
4.1 Checking brake pedal free travel	120
4.2 Checking brake pedal stroke	120
4.3 Checking equalizer working level (anti-imbalance device)	120
5. Checking gear-locked parking brake	120
6. Adjusting parking brake lever	121
7. Checking battery condition	121
7.1 How to read indicator	121
7.2 Charging the battery	122
7.3 Directions for battery storage	122
8. Adjusting air conditioner belt tension	122
EVERY 200 HOURS	123
1. Adjusting toe-in	123
1.1 Adjusting toe-in procedure	123
2. Draining fuel tank water	123
3. Cleaning inner air filter	123
4. Cleaning fresh air filter	124
4.1 Cleaning the filter	124
EVERY 400 HOURS	124
1. Cleaning water separator	124
EVERY 500 HOURS	125
1. Changing engine oil	125
2. Replacing engine oil filter	125
3. Replacing fuel filter	126
4. Replacing hydraulic oil filter	126
5. Checking power steering line	127
6. Checking radiator hose and clamp	127
6.1 Overheating countermeasures	128
7. Checking fuel line	128
8. Checking intake air line	128
9. Checking lift cylinder hose	129
10. Checking air conditioner pipe and hose	130
EVERY 600 HOURS	130
1. Adjusting front axle pivot	130
EVERY 1000 HOURS	130
1. Changing transmission fluid	130
2. Changing front differential case oil	130
3. Changing front axle gear case oil	131
4. Adjusting engine valve clearance	131
EVERY 1000 HOURS OR 1 YEAR	131
1. Replacing air cleaner primary element and secondary element	131
2. Checking exhaust manifold	131
EVERY 1500 HOURS	131
1. Cleaning fuel injector nozzle tip	131
2. Checking and cleaning EGR cooler	131
EVERY 2000 HOURS OR 2 YEARS	131

1. Flushing cooling system and changing coolant	131
2. Antifreeze	132
EVERY 3000 HOURS	133
1. Checking turbocharger	133
2. Checking supply pump	133
3. Checking intake air heater	133
4. Checking and cleaning EGR system	133
5. Cleaning DPF muffler	133
EVERY 1 YEAR	133
1. Checking CAB isolation cushion	133
2. Checking DPF related pipe	133
3. Checking EGR pipe	134
EVERY 2 YEARS	134
1. Replacing breather related rubber pipe	134
2. Replacing boost sensor hose	134
3. Replacing DPF related rubber pipe	134
4. Replacing EGR cooler hose	134
5. Cleaning master cylinder filter	134
EVERY 3 YEARS	134
1. Replacing cables of both parking brakes	134
EVERY 4 YEARS	134
1. Replacing radiator hose (water pipes)	134
2. Replacing fuel lines	134
3. Replacing intake air line	134
4. Replacing power steering line	134
5. Replacing lift cylinder hose	134
6. Replacing master cylinder kit	134
7. Replacing brake seal 1 and 2	134
8. Replacing air conditioner hose	134
SERVICE AS REQUIRED	134
1. Bleeding fuel system	134
2. Bleeding brake system	135
3. Draining clutch housing water	135
4. Replacing fuses	135
5. Replacing slow-blow fuses	137
5.1 Replacement procedure	137
6. Replacing light bulb	138
7. Replacing head lamp	138
8. Lubricating points for door and window	138
9. Adding washer liquid	138
10. Checking amount of refrigerant (gas)	138
STORAGE	140
TRACTOR STORAGE	140
REMOVING THE TRACTOR FROM STORAGE	140
TROUBLESHOOTING	141
ENGINE TROUBLESHOOTING	141
POWERTRAIN TROUBLESHOOTING	142
OPTIONS	143
LIST OF OPTIONS	143
INDEX	144

SAFE OPERATION

Careful operation is your best insurance against an accident.

Read and understand this manual carefully before operating the tractor.

All operators, no matter how much experience they may have, should read this and other related manuals before operating the tractor or any implement attached to it. It is the owner's obligation to instruct all operators in safe operation.

BEFORE OPERATING THE TRACTOR

Know your equipment and its limitations. Read this entire manual before attempting to start and operate the tractor.

1. General

- Pay special attention to safety labels on the tractor.
- Do not operate the tractor or any implement attached to it while under the influence of alcohol, medication, controlled substances or while fatigued.
- Before allowing other people to use your tractor, explain how to operate and have them read this manual before operation.
- Never wear loose, torn, or bulky clothing around tractor. It may catch on moving parts or controls, leading to the risk of an accident.
Use additional safety items, such as a hard hat, safety boots or shoes, eye and hearing protection, gloves and so on, as appropriate or required.
- Do not allow passengers to ride on any part of the tractor at any time. The operator must remain in the tractor seat during operation.
- Check brakes, clutch, linkage pins and other mechanical parts for improper adjustment and wear. Replace worn or damaged parts promptly. Check the tightness of all nuts and bolts regularly. (See MAINTENANCE on page 105.)
- Keep your tractor clean. Dirt, grease, and trash build up may contribute to fires and lead to personal injury.
- Use only implements meeting the specifications listed in this manual or implements approved by KUBOTA.
(See IMPLEMENT LIMITATIONS on page 27.)
- Use proper weights on the front or rear of the tractor to reduce the risk of upsets. When using the front loader, put an implement or ballast on the 3-point hitch to maintain proper balance and braking.

Follow the safe operating procedures specified in the implement or attachment manual.

- The narrower the tread, the greater the risk of a tractor upset. For maximum stability, adjust the wheels to the widest practical tread width for your application.
(See TIRES, WHEELS AND BALLAST on page 91.)

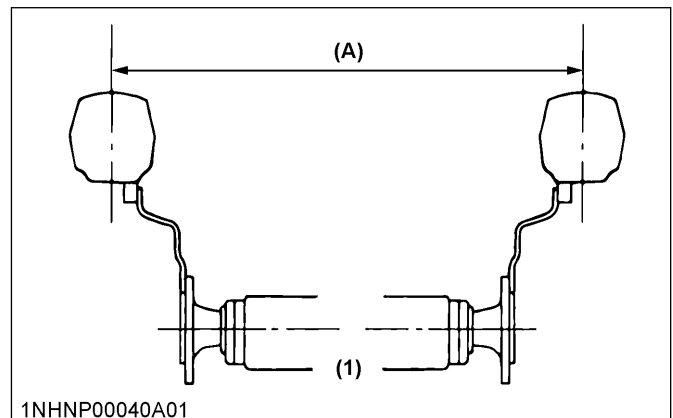

(1) Rear wheels (A) Tread width

- Do not modify the tractor. Unauthorized modification may affect the function of the tractor, which may result in personal injury.

2. CAB and ROPS

- Kubota recommends the use of a CAB or roll over protective structures (ROPS) and seat belt in almost all applications. This combination will reduce the risk of serious injury or death, should the tractor be upset. Check for overhead clearance which may interfere with a CAB or ROPS.
- If the CAB or ROPS is loosened or removed for any reason, make sure that all parts are reinstalled correctly before operating the tractor.
- Never modify or repair any structural member of a CAB or ROPS because welding, bending, drilling, grinding, or cutting may weaken the structure.
- If any structural member of the CAB or ROPS is damaged, replace the entire structure at your local KUBOTA Dealer.
- Always use the seat belt if the tractor has a CAB or ROPS. Do not use the seat belt if a retractable ROPS is being retracted or there is no ROPS. Check the seat belt regularly and replace if frayed or damaged.

! SAFE OPERATION

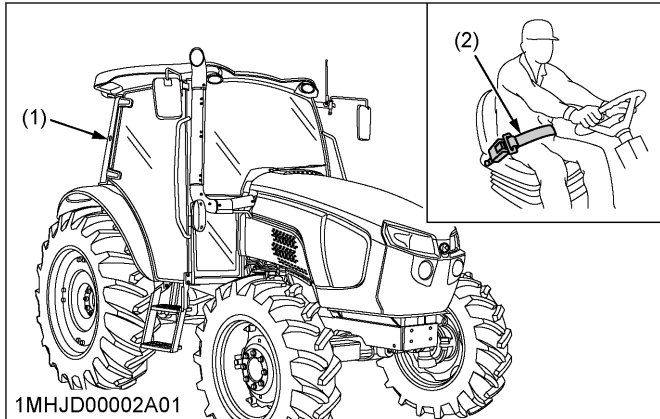

- (1) CAB
- (2) Seat belt

- The CAB is not tested for falling object protection structure (FOPS).
- The CAB fulfills the requirements of category 2 (EN 15695-1: 2009) for hazardous substances. (See CAB CLASSIFICATION AND MAINTENANCE on page 96.)
- The CAB provides protection against dust but not against aerosols and vapors.
- The CAB cannot be used under conditions requiring protection against aerosols and vapors.

OPERATING THE TRACTOR

Operator safety is a priority. Safe operation, specifically with respect to overturning hazards, entails understanding the equipment and environmental conditions at the time of use.

Some prohibited uses which can affect overturning hazards include traveling and turning with implements, loads carried too high and so on. This manual sets forth some of the obvious risks, but the list is not, and cannot be, exhaustive. It is the operator's responsibility to be alert for any equipment or environmental condition that could compromise safe operation.

1. Starting to operate the tractor

- Always sit in the operator's seat when starting the engine or operating levers or controls. Adjust seat per instructions in the operating the tractor section. Never start the engine while standing on the ground.
- Before starting the engine, make sure that all levers (including auxiliary control levers) are in their neutral positions, that both parking brakes are applied, and that both the clutch and the power take-off (PTO) are disengaged or "OFF". Fasten the seat belt if the tractor has a CAB, a fixed ROPS or a retractable ROPS in the upright and locked position.
- Do not start the engine by shorting across starter terminals or bypassing the safety start switch. The

machine may start in gear and move if the normal starting circuitry is bypassed.

- Do not operate or idle the engine in an unventilated area. Carbon monoxide gas is colorless, odorless, and deadly.
- Check that the operator presence control (OPC) system is functioning correctly before each time you use the tractor. Test the safety systems. (See Checking engine start system on page 116.) Do not operate unless they are functioning correctly.

2. Working the tractor

- Pull only from the drawbar. Never hitch to axle housing or any other point except the drawbar; such arrangements will increase the risk of serious personal injury or death due to a tractor upset.

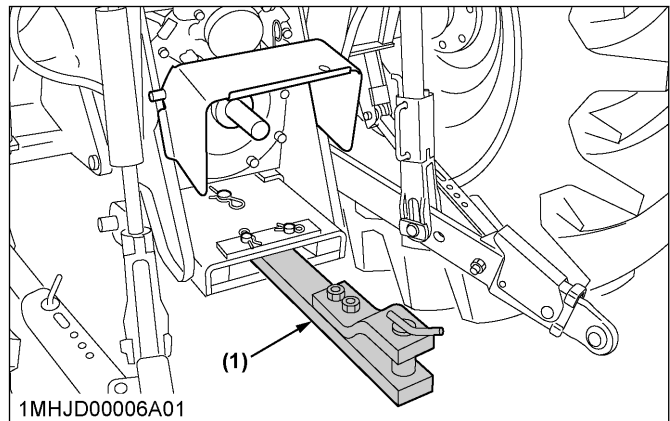

- (1) Drawbar

- For trailing PTO-driven implements, set the drawbar to the towing position.
- Attach pulled or towed loads to the drawbar only.
- Keep all shields and guards in place. Replace any that are missing or damaged.
- Avoid sudden starts. To avoid upsets, slow down when turning, on uneven ground, and before stopping.
- The tractor cannot turn with the differential locked and attempting to do so could be dangerous.
- Do not operate near ditches, holes, embankments, or other ground surface features which may collapse under the tractor's weight. The risk of tractor upset is even higher when the ground is loose or wet. Tall grass can hide obstacles; walk the area first to be sure.
- Watch where you are going at all times. Watch for and avoid obstacles. Be alert at row ends, near trees, and other obstructions.
- When working in groups, always let the others know what you are going to do before you do it.
- Never try to get on or off a moving tractor.

- Always sit in the operator's seat when operating levers or controls.
- Do not stand between tractor and implement or trailed vehicle unless both parking brakes are applied.
- Do not operate the tractor when there is a possibility of lightning. Even if the tractor is equipped with a CAB, the operator is not protected from lightning.

3. Instructional seat (if equipped)

- Always wear your seat belt and stabilize your body by holding the handrail on the CAB frame.
- It is not intended to carry children nor any other person for any other purpose.
- The left-hand door must be closed at all time whenever the instructional seat is occupied and the tractor is in motion.
- Do not permit others to ride, except on the designated instructional seat.
- Use caution to avoid the risks of obstructing operator's view, falling from the machine and interfering with controls.
- Do not start and stop the tractor suddenly, nor take a sharp turn.
- Do not use the instructional seat if the seat belt or the door lock fails to function.
- Do not use the instructional seat for transport.
- When opening or closing the door while being seated in the instructional seat, move the door slowly. This is to prevent his or her hand(s) from getting caught by the door or his or her body to hit against the door.

4. Safety for children

Tragedy can occur if the operator is not alert to the presence of children. Children generally are attracted to machines and the work they do.

- Never assume that children will remain where you last saw them.
- Keep children out of the work area and under the watchful eye of another responsible adult.
- Be alert and shut your machine down if children enter the work area.
- Never carry children on your machine. There is no safe place for them to ride. They may fall off and be run over or interfere with your control of the machine.
- Never allow children to operate the machine even under adult supervision.
- Never allow children to play on the machine or on the implement.
- Use extra caution when backing up. Look behind and down to make sure area is clear before moving.

5. Operating on slopes

Slopes are a major factor related to loss-of-control and tip-over accidents, which can result in severe injury or death. All slopes require extra caution.

- To avoid upsets, always back up steep slopes. If you cannot back up the slope or if you feel uneasy on it, do not operate on it. Stay off slopes too steep for safe operation.
- Driving forward out of a ditch, mired condition or up a steep slope increases the risk of rear rollovers. Always back out of these situations. Extra caution is required with 4-wheel drive models because their increased traction can give the operator false confidence in the tractor's ability to climb slopes.
- Keep all movement on slopes slow and gradual. Do not make sudden changes in speed, direction or braking, nor make sudden motions with the steering wheel.
- Avoid disengaging the clutch or changing gears when climbing or going down a slope. If on a slope, disengaging the clutch or changing gears to neutral could cause the loss of control.
- Special attention should be paid to the weight and location of implements and loads as such will affect the stability of the tractor.
- To improve stability on slopes, set the widest possible wheel tread.
(See TIRES, WHEELS AND BALLAST on page 91.)
Follow the recommendations for proper ballasting.
- To avoid free wheeling:
 - Do not shift the shuttle lever while on a slope.
 - Stop completely by using the brakes and by depressing the clutch pedal, then shift the shuttle lever.
 - Start off after selecting shuttle direction, by releasing the clutch pedal.
- When driving down a slope, ensure that 4-wheel drive is engaged to increase traction (if equipped).

6. Driving the tractor on the road

- Lock the 2 brake pedals together to help assure straight-line stops. Uneven braking at road speeds could cause the tractor to tip over.

! SAFE OPERATION

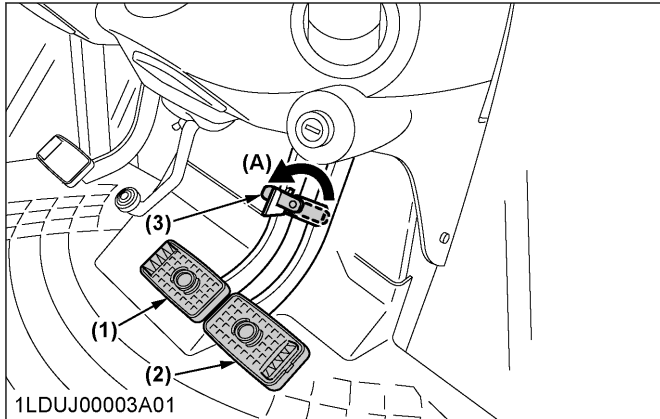

- (1) Brake pedal (LH)
- (2) Brake pedal (RH)
- (3) Brake pedal lock

(A) "Lock the brake pedals whenever traveling on the road"

- Check the front wheel engagement. The braking characteristics are different between 2 and 4-wheel drive. Be aware of the difference and use carefully.
- When driving down a slope, ensure that the 4-wheel drive is engaged to increase traction (if equipped).
- Always slow down the tractor before turning. Turning at high speed may tip over the tractor.
- Observe all local traffic and safety regulations. Use the registration plate as required.

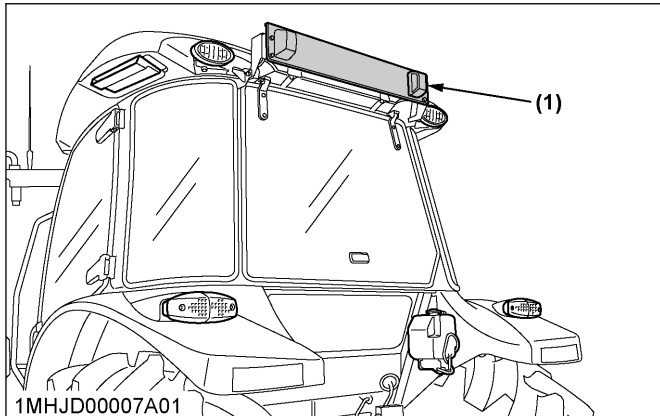

- (1) Registration plate

- Turn the headlights on. Dim them when meeting another vehicle.
- Drive at speeds that allow you to maintain control at all times.
- Do not apply the differential lock while traveling at road speeds. The tractor may run out of control.
- Avoid sudden motions of the steering wheel as they can lead to a dangerous loss of stability. The risk is especially great when the tractor is traveling at road speeds.
- Do not operate an implement while the tractor is on the road. Lock the 3-point hitch in the raised position.
- Set the 3-point hitch lowering speed knob in the "LOCK" position to hold the implement in the raised position.

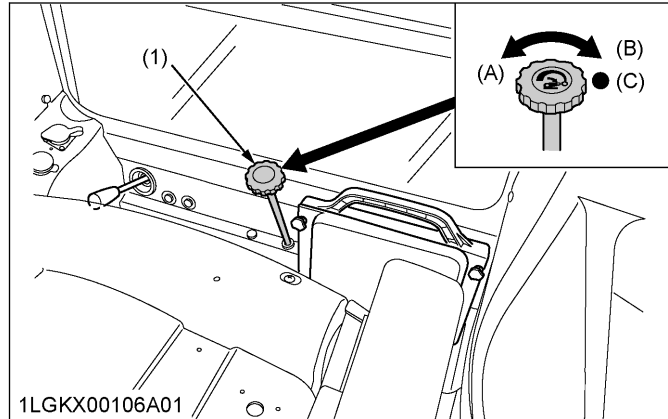

- (1) 3-point hitch lowering speed knob

(A) "FAST"
(B) "SLOW"
(C) "LOCK"

PARKING THE TRACTOR

- Disengage the PTO, lower all implements to the ground, place all control levers in their neutral positions, set both parking brakes, stop the engine, remove the key from the ignition and lock the CAB door (if equipped).
Leaving transmission in gear with the engine stopped will not prevent the tractor from rolling.
- Make sure that the tractor has come to a complete stop before dismounting.
- Avoid parking on steep slopes. If at all possible, park on a firm and level surface; if not, park across a slope and chock the wheels.
Failure to comply with this warning may allow the tractor to move and could cause injury or death.

OPERATING THE PTO

- Wait until all moving components have completely stopped before getting off the tractor, connecting, disconnecting, adjusting, cleaning, or servicing any PTO driven equipment.
- Keep the PTO shaft cover in place at all times. Replace the PTO shaft cap when the shaft is not in use.

! SAFE OPERATION

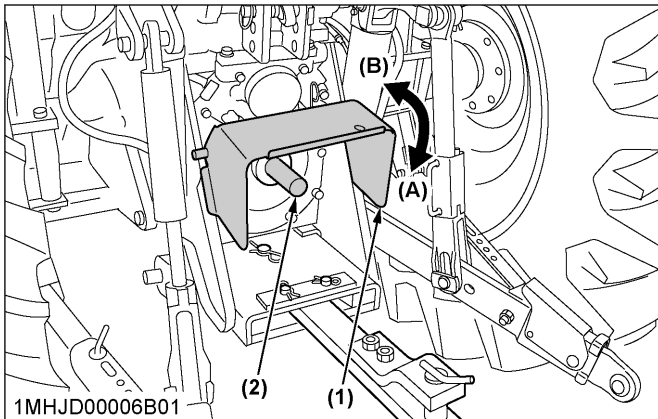

(1) PTO shaft cover (A) "NORMAL POSITION"
 (2) PTO shaft cap (B) "RAISED POSITION"

- Before installing or using PTO driven equipment, read the manufacturer's manual and review the safety labels attached to the equipment.
- When operating stationary PTO driven equipment, always apply both of the tractor's parking brakes and place chocks behind and in front of the rear wheels. Stay clear of all rotating parts. Never step over rotating parts.

USING 3-POINT HITCH

- Use the 3-point hitch only with equipment designed for the appropriate category of 3-point hitch usage.
- When using a 3-point hitch mounted implement, be sure to install the proper counterbalance weight on the front of the tractor.
- To avoid injury from separation: Do not extend the lift rod beyond the groove on the threaded rod.

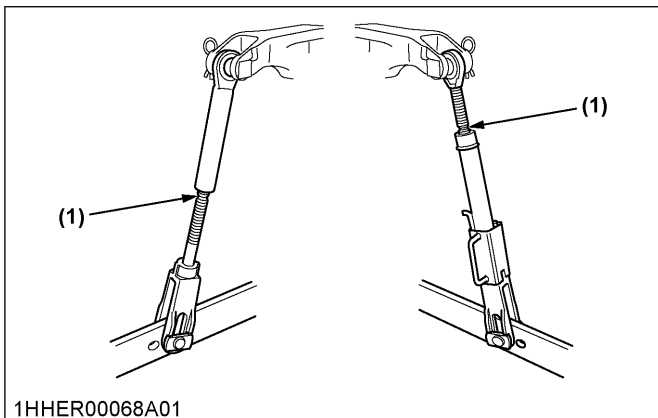

(1) Groove

SERVICING THE TRACTOR

Before servicing the tractor, park it on a firm, flat and level surface, set both parking brakes, lower all implements to the ground, place the gear shift lever in neutral, stop the engine and remove the key.

- Allow the tractor time to cool off before working on or near the engine, muffler, radiator and so on.
- Do not remove radiator cap while the coolant is hot. When cool, slowly rotate cap to the first stop and allow sufficient time for excess pressure to escape before removing the cap completely. If the tractor has a coolant recovery tank, add coolant or water to the tank, not the radiator.
 (See Checking coolant level on page 113.)
- Always stop the engine before refueling. Avoid spills and overfilling. Use only approved fuels.
- Always use grounded refueling facilities.
- Do not smoke when working around the battery or when refueling. Keep all sparks and flames away from battery and fuel tank. The battery presents an explosive hazard because it gives off hydrogen and oxygen especially when recharging.
- Before "jump-starting" a dead battery, read and follow all of the instructions.
 (See JUMP STARTING on page 46.)
- Keep first aid kit and fire extinguisher handy at all times.
- Disconnect the battery's ground cable before working on or near electric components.
- To avoid the possibility of battery explosion, do not use or charge the refillable type battery if the fluid level is below the **[LOWER]** (lower limit level) mark. Check the fluid level regularly and add distilled water as required so that the fluid level is between the **[UPPER]** and **[LOWER]** levels.
- To avoid sparks from an accidental short circuit, always disconnect the battery's ground cable (-) first and reconnect it last.

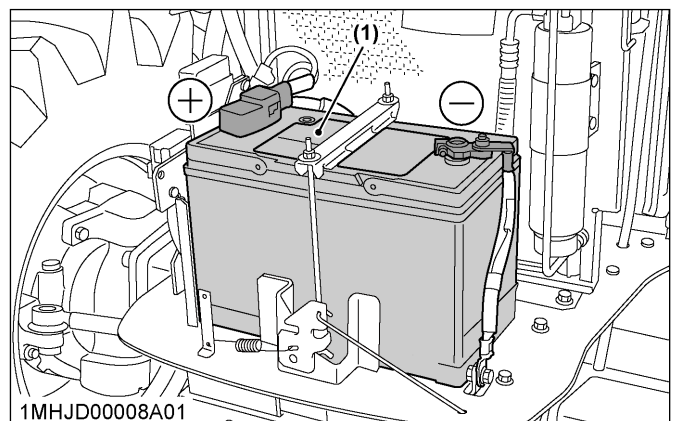

(1) Battery

- Do not attempt to mount a tire on a rim. This should be done by a qualified person with the proper equipment.
- Always maintain the correct tire pressure. Do not inflate tires above the recommended pressure shown in the operator's manual.

! SAFE OPERATION

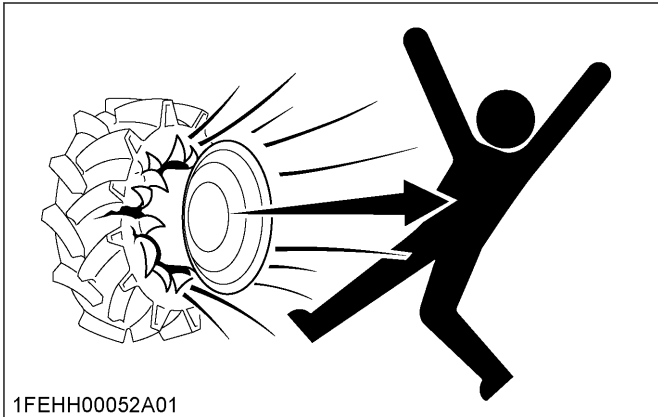

- Securely support the tractor when either changing wheels or adjusting the wheel tread width.
- Make sure that wheel bolts have been tightened to the specified torque.
- Disconnect the battery's ground cable and stop the engine to avoid the possibility of the machine runaway due to 4WD braking system during testing, service or repair with only rear wheels off the ground.
- Do not work under any hydraulically supported devices. They can settle, suddenly leak down, or be accidentally lowered. If it is necessary to work under the tractor or any machine elements for servicing or adjustment, securely support them with stands or suitable blocking beforehand.
- Escaping hydraulic fluid under pressure has sufficient force to penetrate the skin, causing serious personal injury. Before disconnecting hydraulic lines, be sure to release all residual pressure. Before applying pressure to the hydraulic system, make sure that all connections are tight and that all lines, pipes, and hoses are free of damage.

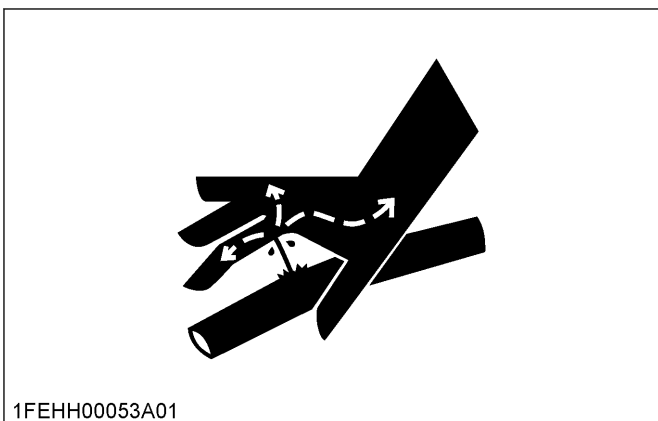

- Fluid escaping from pinholes may be invisible. Do not use hands to search for suspected leaks; use a piece of cardboard or wood. Use of safety goggles or other eye protection is also highly recommended. If injured by escaping fluid, see a medical doctor at once. This fluid will produce gangrene or severe allergic reactions.

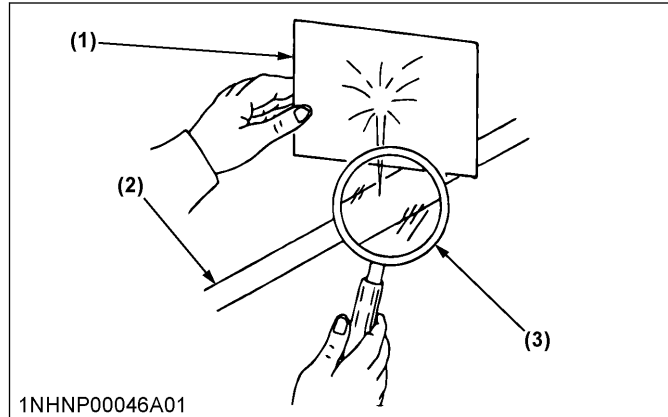

- (1) Cardboard
- (2) Hydraulic line
- (3) Magnifying glass

- Do not open the high-pressure fuel system. High-pressure fluid remaining in fuel lines can cause serious injury. Do not disconnect or attempt to repair fuel lines, sensors, or any other components between the high-pressure fuel pump and injectors on engines with high-pressure common rail fuel system.
- To avoid hazardous high voltage, turn the key switch to the "OFF" position if it is necessary to check or repair the computer, harness or connectors.
- During diesel particulate filter (hereinafter called DPF) regenerating operations, exhaust gases and exhaust filter components reach temperatures hot enough to burn people or ignite or melt common materials.
- Keep the tractor away from people, animals or structures which may be susceptible to harm or damage from hot exhaust gases.
- To prevent fires, keep the DPF muffler and its surroundings clear of anything flammable and keep clean at all times.
- To avoid fire hazard:
After use and pressure-washing, make sure there is nothing flammable near the exhaust pipe. Grass or twigs under the hood may cause fire.
- During regeneration, white exhaust gas may be visible. Do not allow regeneration to happen in an unventilated place.
- During regeneration, do not leave the tractor.
- The improper disposal or burning of waste causes environmental pollution and can be punishable by your local laws and regulations.
 - When draining fluids from the tractor, place a container underneath the drain port.
 - Do not pour waste onto the ground, down a drain, or into any water source (such as rivers, streams, lakes, marshes, seas, and oceans).
 - Waste products such as used oil, fuel, coolant, hydraulic fluid, refrigerant, solvent, filters, rubber, batteries, and harmful substances, can harm the environment, people, pets and wildlife.

SAFE OPERATION

Please dispose of properly.
See your local recycling center or KUBOTA
Dealer to learn how to recycle or get rid of
waste products.

! SAFE OPERATION

SAFETY LABELS

(1) Part No. 3B794-4719-1

Do not touch hot surface like muffler, and so on.



(2) Part No. 6C782-4958-1

Do not get your hands close to engine fan and belt.

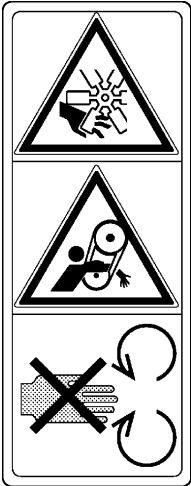

(3) Part No. 3Y205-9892-2

! DANGER/POISON

<p>SHIELD EYES. EXPLOSIVE GASES CAN CAUSE BLINDNESS OR INJURY.</p>	<p>NO SPARKS. FLAMES CAN CAUSE BLINDNESS OR SEVERE BURNS.</p>	<p>SULFURIC ACID CAN CAUSE BLINDNESS OR SEVERE BURNS.</p>
--	---	---

KEEP OUT OF REACH OF CHILDREN. DO NOT TIP. DO NOT OPEN BATTERY.

FLUSH EYES IMMEDIATELY WITH WATER. GET MEDICAL HELP FAST.

CALIFORNIA PROPOSITION 65
! WARNING: THIS PRODUCT CAN EXPOSE YOU TO CHEMICALS INCLUDING LEAD, WHICH IS KNOWN TO THE STATE OF CALIFORNIA TO CAUSE CANCER AND BIRTH DEFECTS OR OTHER REPRODUCTIVE HARM. FOR MORE INFORMATION GO TO WWW.P65WARNINGS.CA.GOV

105E41R 12V	
AMP. HR (5HR)	80
AMP. HR (20HR)	100
RESERVE CAPACITY (MIN)	160
BCI CCA	900
EN CCA	800

S.O.C Indicator OK Charge Replace

Pb

DK103027

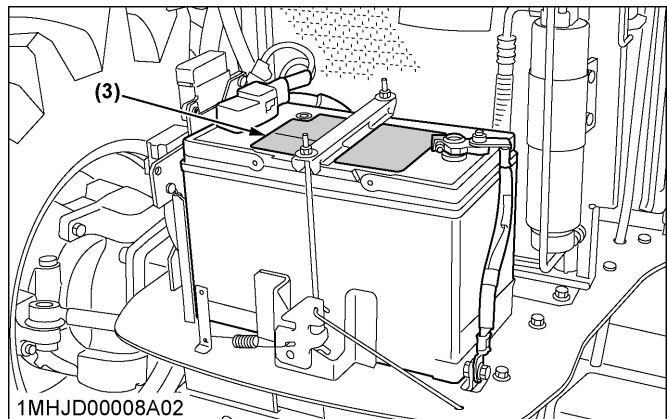
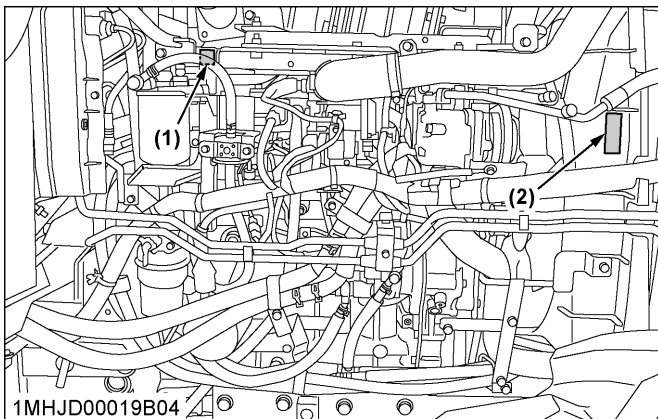

! SAFE OPERATION

(1) Part No. 6C782-4958-1

Do not get your hands close to engine fan and belt.

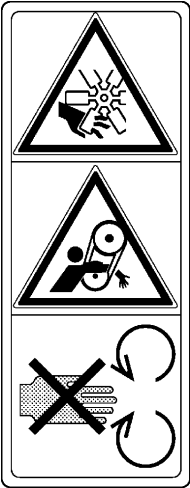

(2) Part No. TC660-9861-1

! WARNING
TO AVOID PERSONAL INJURY OR DEATH:
 When the Diesel Particulate Filter (DPF) is in the regenerating mode, the exhaust gas and the DPF muffler become hot. During regeneration, take into account that the muffler will be very hot and keep the machine away from other people, animals, plants, and flammable material. Also keep the area near the DPF muffler clean and away from flammable material.

(3) Part No. 3B794-4719-1

Do not touch hot surface like muffler, and so on.



(4) Part No. 3A481-9853-1

Diesel fuel only

No fire

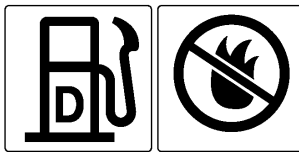

(5) Part No. 32310-4958-1

Do not touch hot surface like muffler, and so on.

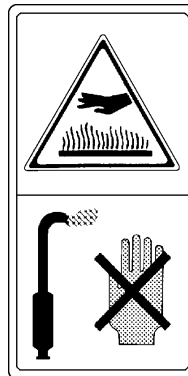

(6) Part No. 3J080-3822-1

! WARNING
TO AVOID FIRE HAZARD :
 After use and/or pressure-washing, make sure there is nothing flammable near the exhaust pipe. Grass or twigs under the bonnet may cause fire.

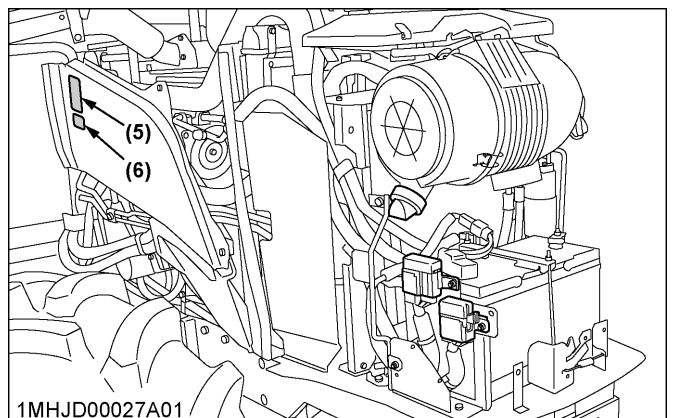
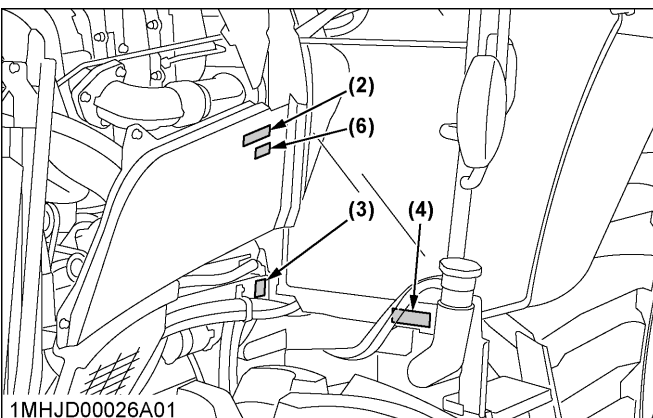
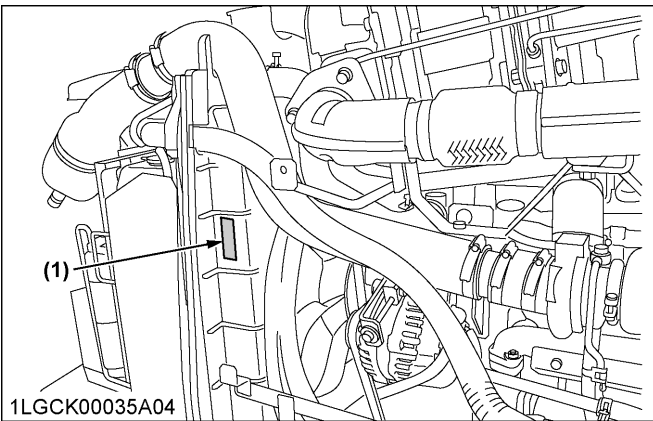

! SAFE OPERATION

(1) Part No. 3C581-9858-1

	<p align="center">! DANGER</p> <p>TO AVOID POSSIBLE INJURY OR DEATH FROM A MACHINE RUNAWAY.</p> <ol style="list-style-type: none"> 1. Do not start engine by shorting across starter terminals or bypassing the safety start switch. Machine may start in gear and move if normal starting circuitry is bypassed. 2. Start engine only from operator's seat with transmission and PTO OFF. Never start engine while standing on the ground.
--	---

(2) Part No. 3F240-9857-1

<p align="center">! WARNING</p> <p>To avoid free wheeling when shifting the shuttle lever while on a slope: Stop completely by using the brake and by depressing the clutch pedal. Start off after selecting shuttle direction by releasing the clutch pedal.</p>
--

(3) Part No. 6C150-4743-1

<p align="center">! WARNING</p> 	<p>BEFORE DISMOUNTING TRACTOR:</p> <ol style="list-style-type: none"> 1. ALWAYS SET PARKING BRAKE. Leaving transmission in gear with the engine stopped will not prevent tractor from rolling. 2. PARK ON LEVEL GROUND WHENEVER POSSIBLE. If parking on a slope, position tractor across the slope. 3. LOWER ALL IMPLEMENTS TO THE GROUND. 4. STOP THE ENGINE.
--	---

(4) Part No. 3B791-9778-1

If the optional instructional seat is installed

<p align="center">! WARNING</p> <p>TO AVOID PERSONAL INJURY OR DEATH WHEN USING THE INSTRUCTIONAL SEAT:</p> <ul style="list-style-type: none"> • Always wear your seat belt and stabilize your body by holding the handrail on the CAB frame. • The instructional seat is not intended to carry children nor any other person for any purposes. • The left hand door must be closed at all time whenever the instructional seat is occupied and the tractor is in motion. • Do not permit others to ride, except on the designated instructional seat. • Use caution to avoid the risks of obstructing operator's view, falling from the machine and interfering with controls. • Do not start and stop the tractor suddenly, nor take sharp turn • Do not use the instructional seat if the seat belt or the door lock fails to function. • Do not use the instructional seat for transport. • Fold the instructional seat when not in use, because otherwise the operator may tip over when he or she gets on or off the cabin. • When opening and closing the door from the instructional-seat-sitting position, move the door slowly. This is to prevent his or her hand(s) from getting caught by the door or his or her body to hit against the door.

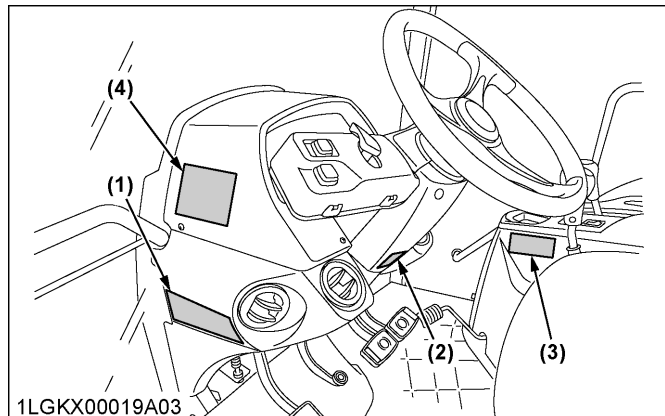

(1) Part No. 3S205-9836-1

(2) Part No. TA040-4902-1

! WARNING

TO AVOID PERSONAL INJURY OR DEATH:

1. Read and understand the operator's manual before operation.
2. Before starting the engine, make sure that everyone is at a safe distance from tractor and the PTO is off.
3. Do not allow passengers on the tractor at any time.
4. Before allowing other people to use the tractor, have them read the operator's manual.
5. Check the tightness of nuts and bolts regularly.
6. Keep all shields in place and stay away from all moving parts.
7. Lock the two brake pedals together before driving on the road.
8. Slow down for turns, or rough roads, or when applying individual brakes.
9. On public roads use SMV emblem and hazard lights, if required by local traffic and safety regulations.
10. Pull only from the drawbar.
11. Before dismounting, lower the implement to the ground, set the parking brake, stop the engine and remove the key.
12. Securely support tractor and implements before working underneath.

! WARNING



TO AVOID INJURY OR DEATH FROM ROLL-OVER:

Always use seat belt when driving.

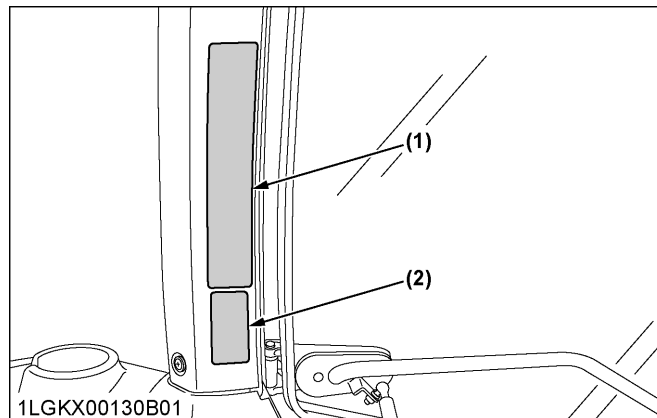

SAFE OPERATION

(1) Part No. 3B291-9856-1

 WARNING
TO AVOID PERSONAL INJURY OR DEATH FROM SEPARATION:

DO NOT EXTEND LIFT ROD BEYOND THE GROOVE ON THE THREADED ROD.



The diagram shows two views of a lift rod assembly. On the left, labeled 'LH', a lift rod is shown with a 'GROOVE' on its threaded section. On the right, labeled 'RH', a lift rod is shown with a 'GROOVE' on its threaded section.

(2) Part No. TA040-4935-1

 WARNING

TO AVOID PERSONAL INJURY:

1. Attach pulled or towed loads to the drawbar only.
2. Use the 3-point hitch only with equipment designed for 3-point hitch usage.

(3) Part No. TA040-4959-3

 WARNING

TO AVOID PERSONAL INJURY.

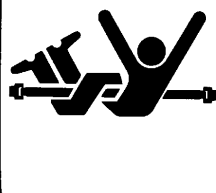

The diagram shows a person being struck by a PTO shield. The person is shown in a falling position, and the PTO shield is shown in a raised position.

1. Keep PTO shield in place at all times.
2. Do not operate the PTO at speeds faster than the speed recommended by the implement manufacturer.
3. For trailing PTO-driven implements, set drawbar at towing position. (see operator's manual)

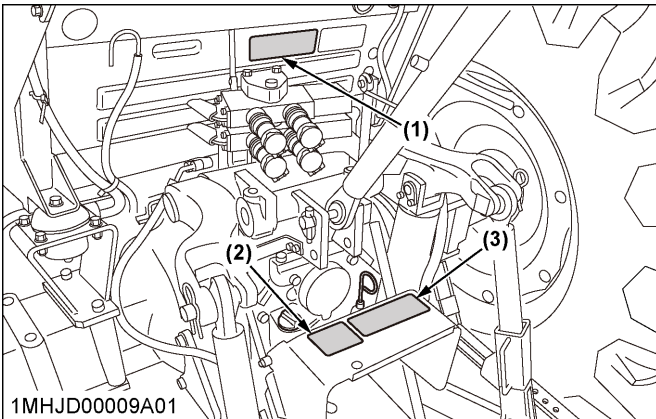

CARE OF SAFETY LABELS

- Keep safety labels clean and free from obstructing material.
- Clean safety labels with soap and water, and dry with a soft cloth.
- Replace damaged or missing safety labels with new labels from your local KUBOTA Dealer.
- If a component with safety label(s) attached is replaced with a new part, make sure new label(s) is (are) attached in the same location(s) as the replaced component.
- Attach new safety labels by applying on a clean dry surface and pressing any bubbles to the outside edge.

SERVICING OF TRACTOR

Your dealer has knowledge of your new tractor and has the desire to help you get the most value from it.

After reading this manual thoroughly, you will find that you can do some of the regular maintenance yourself. However, when in need of parts or major service, be sure to see your KUBOTA Dealer.

For service, contact the KUBOTA Dealership from which you purchased your tractor or your local KUBOTA Dealer.

When in need of parts, be prepared to give your dealer the tractor, CAB/ROPS and engine serial numbers.

Locate the serial numbers now and record them in the space provided.

Date of purchase	
Name of dealer	

To be filled in by purchaser

	Type	Serial No.
Tractor		
CAB/ROPS		
Engine		

To be filled in by purchaser

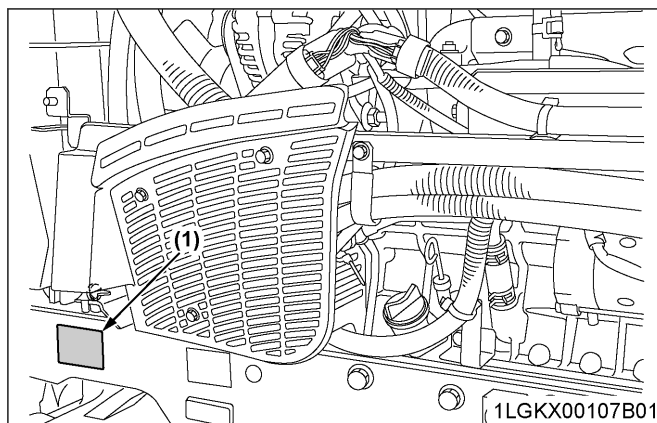

(1) Tractor identification plate

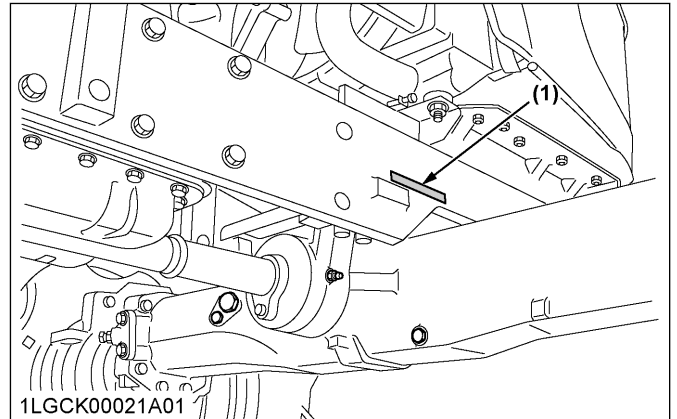

(1) Tractor serial number

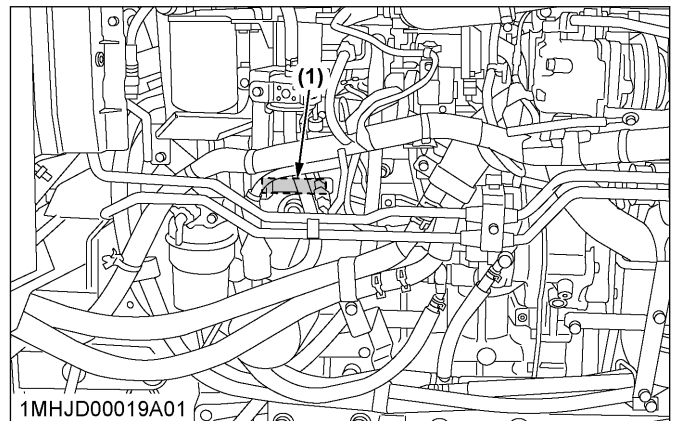

(1) Engine serial number

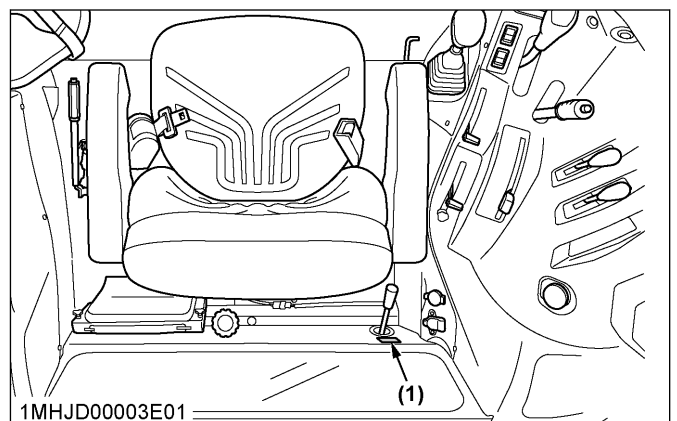

(1) CAB identification plate (CAB serial number)

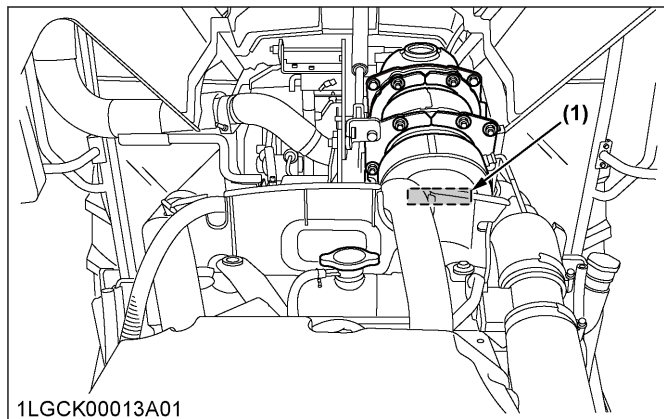

(1) Diesel particulate filter (DPF) serial number

WARRANTY

This tractor is warranted under the **KUBOTA Limited Express Warranty**, a copy of which may be obtained from your selling dealer.

No warranty shall, however, apply if the tractor has not been handled according to the instruction given in the operator's manual, even if it is within the warranty period.

SCRAPPING THE TRACTOR AND ITS PROCEDURE

To put the tractor out of service, correctly follow the local rules and regulations of the country or territory where you scrap it.

If you have questions, consult your local KUBOTA Dealer.

SPECIFICATIONS

SPECIFICATION TABLE

Model			M5091	M5111
			4WD	4WD
Engine	Model		V3800-CR-TE4-G1	V3800-CR-TIE4-G1
	Type		4-cylinder inline, common rail system, direct injection	4-cylinder inline, common rail system, direct injection, intercooler
	Number of cylinders		4	
	Total displacement	cm ³	3769	
	Bore and stroke	mm	100 × 120	
	Rated revolution	rpm	2600	
	Low idling revolution	rpm	800 to 850	
	Rated engine HP (97/68/EC)	kW (PS)	69.4 (94.3)	82.4 (112.0)
	Net power*1	kW (PS)	63.9 (86.8)	76.9 (104.5)
	Maximum torque	N · m/rpm	320/1500	364/1500
	Battery capacity		12 V, RC: 160 min, CCA 900 A	
	Fuel tank capacity	L	105	
	Engine oil capacity	L	10.7	
	Coolant capacity	L	10.0	
Dimensions	Overall length		mm 3955	
	Overall width (minimum tread)		mm 2047	
	Overall height		mm 2650	
	Wheel base		mm 2250	
	Tread	Front	mm 1611	
		Rear	mm 1503 to 1695	
Minimum ground clearance		mm 466 (drawbar bracket)		
Weight		kg 3270		
Traveling system	Standard tire size	Front tires	360/70R24	
		Rear tires	480/70R34	
	Clutch		Hydraulic multiple wet disks	
	Steering		Hydraulic power steering	
	Braking system		Hydraulically operated wet disk	
Differential		Bevel gears with differential lock (rear)		
Hydraulic unit	Hydraulic control system		Position, draft (top link sensing) and mix control	
	Pump capacity	L/min	64.3	
	3-point hitch		Category 2	
	Max. lifting force	At lifting points*2	kg 3900	
	Remote hydraulic control		2 standard (3rd and flow control valve optional)	
	Remote control valve coupler		ISO 7241-1 standards "A"	

(Continued)

SPECIFICATIONS

Model			M5091	M5111
			4WD	4WD
Hydraulic unit	System pressure	MPa (kgf/cm ²)	20.2 (206)	
	Traction system		Swinging drawbar, adjustable in direction	
PTO	Live PTO (independent)	Direction of turning	Clockwise, viewed from tractor rear	
		PTO/engine speed	rpm	6 spline: 540/2035 6 spline: 540E/1519 21 spline: 1000/2389
The level of protection against hazardous substance*3			Category 2	

The company reserves the right to change the specifications without notice.









*1 Manufacturer's estimate

*2 At lower link end with links horizontal.

*3 According to EN 15695-1: 2009

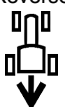
TRAVELING SPEEDS

Model with dual speed

Model			M5111	
Rear tire size			F36 / R36	
Rear tire size			480/70R34	
Shuttle shift lever	Range gear shift lever	Main gear shift lever	Dual speed: H	Dual speed: L
			km/h	km/h
Forward 		1	0.40	0.34
		2	0.55	0.46
		3	0.71	0.60
		4	0.91	0.77
		5	1.13	0.95
		6	1.61	1.36
		1	2.7	2.3
		2	3.7	3.1
		3	4.8	4.0
		4	6.2	5.2
		5	7.7	6.5
		6	11.0	9.2
		1	12.1	10.1
		2	16.5	13.9
		3	21.3	17.9
		4	27.5	23.1
		5	33.9	28.5
		6	38.8*1	32.7*1
Reverse 		1	0.41	0.34
		2	0.56	0.47
		3	0.72	0.60
		4	0.92	0.78
		5	1.14	0.96
		6	1.63	1.38
		1	2.8	2.3
		2	3.8	3.2
		3	4.9	4.1
		4	6.3	5.3
		5	7.8	6.5
		6	11.1	9.4
		1	12.2	10.3
		2	16.7	14.0
		3	21.5	18.1
		4	27.8	23.4
		5	34.3	28.9
		6	39.3*1	33.1*1









At rated engine rpm

The company reserves the right to change the specifications without notice.

*1 At 2080 engine rpm.

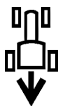
SPECIFICATIONS

Model without dual speed

Model			M5111/M5091
Rear tire size			F18 / R18
Rear tire size			480/70R34
Shuttle shift lever	Range gear shift lever	Main gear shift lever	km/h
Forward 		1	0.37
		2	0.51
		3	0.66
		4	0.85
		5	1.05
		6	1.50
		1	2.5
		2	3.5
		3	4.5
		4	5.8
		5	7.1
		6	10.2
		1	11.2
		2	15.4
		3	19.8
		4	25.6
		5	31.6
		6	39.2 ^{*1}
Reverse 		1	0.37
		2	0.51
		3	0.66
		4	0.85
		5	1.04
		6	1.50
		1	2.5
		2	3.5
		3	4.5
		4	5.8
		5	7.1
		6	10.2
		1	11.2
		2	15.3
		3	19.7
		4	25.4
		5	31.4
		6	39.0 ^{*1}

At rated engine rpm

The company reserves the right to change the specifications without notice.

*1 At 2080 engine rpm.

IMPLEMENT LIMITATIONS

The tractor has been thoroughly tested for proper performance with implements sold or approved by Kubota. Use with implements which are not sold or approved by Kubota and which exceed the maximum specifications listed in the following table, or which are otherwise unfit for use with the tractor, may result in malfunctions or failures of the tractor, damage to other property and injury to the operator or others. Any malfunctions or failures of the tractor resulting from use with improper implements are not covered by the warranty.

Tread (max. width)		Lower link end max. lifting capacity: W0
Front	Rear	
1628 mm	1714 mm	3900 kg

Actual figures		
Implement weight and/or size: W1	Max. drawbar load: W2	Trailer loading weight max. capacity: W3
As in the following list (See IMPLEMENT SPECIFICATION TABLE on page 28.)	1500 kg	7000 kg

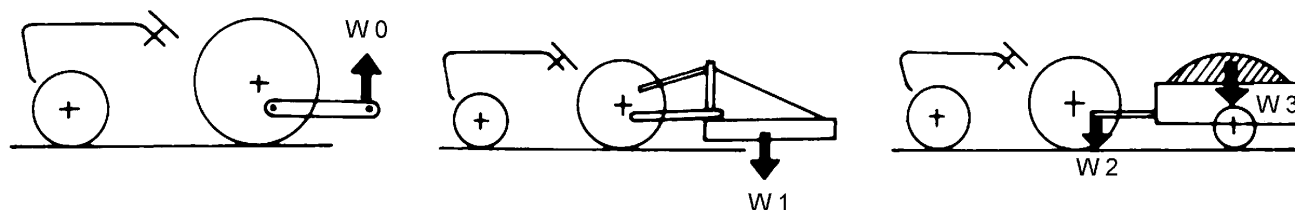

1AGAIAZAP121B

- W0 Lower link end max. hydraulic lifting capacity
- W1 Implement weight-the implement's weight which can be put on the lower link
- W2 Max. drawbar load
- W3 Trailer loading weight-the max. loading weight for trailer

NOTE :

- Implement size may vary depending on soil operating conditions.
- Strictly follow the instructions outlined in the operator's manual of the mounted or trailed machinery or trailer, and do not operate the combination tractor-machine or tractor-trailer unless all instructions have been followed
- Forestry application
 The following hazards exist:
 - toppling trees, primarily with a tree grab-crane mounted at the rear of the tractor;
 - penetrating objects in the operator's enclosure, primarily with a winch mounted at the rear of the tractor.

Optional equipment such as operator protective structure (OPS), falling object protective structure (FOPS), and so on. to deal with these hazards and other related hazards is not available for this tractor. Without such optional equipment, use is limited to tractor specific applications like transport and stationary work.

IMPLEMENT SPECIFICATION TABLE

No.	Implement		Remarks		M5091	M5111	
1	Slurry tank		Max. tank capacity	L	4000		
			Max. load capacity	kg	5000		
2	Trailer		Max. load capacity	kg	7000		
			Max. drawbar load	kg	1500		
3	Mower	Rotary-cutter	Max. cutting width	mm	2800		
			Max. weight	kg	600		
		Flail mower (heavy)	Max. cutting width	mm	3660		
			Max. weight	kg	1000		
Sickle bar	Max. cutting width	mm	2743				
4	Sprayer		Max. tank capacity	Mid	L	800	1000
				Rear 3P	L	800	1000
				Drawbar	L	4500	5000
5	Rotary tiller		Max. tilling width	mm	2400		
			Max. weight	kg	1000		
6	Bottom plow		Max. size		16 in. x 4 18 in. x 3 24 in. x 1	14 in. x 5 16 in. x 4 20 in. x 3 24 in. x 1	
			Max. weight (3P type)	kg	750	900	
7	Disk harrow	3P type	Max. size		24 in. x 24	24 in. x 28	
			Max. harrowing width	mm	2850	3300	
			Max. weight	kg	750	900	
		Drawbar type	Max. harrowing width	mm	3660	4300	
8	Disc plow		Max. size		26 in. x 4 28 in. x 4	26 in. x 4 28 in. x 4	
			Max. weight	kg	750	900	
9	Subsoiler		Numbers of cultivating tines		2		
			Cultivating depth	mm	500	550	
10	Cultivator		Max. width	mm	4880	5490	
			Number of rows		6		
			Max. weight	kg	750	900	
11	Front blade*1*2		Max. cutting width	mm	2430	2600	
			Max. oil pressure	MPa	19.6		
12	Rear blade		Max. cutting width	mm	2430	2600	
			Max. oil pressure	MPa	19.6		
13	Front loader*1*2		Max. lifting capacity (bucket pivot pin, max. height)	kg	1880*3		
			Max. oil pressure (extra hydro kit)	MPa	20.5		
14	Box blade		Max. cutting width	mm	2430		
			Max. weight	kg	750	800	
15	Back hoe *2		Max. digging depth	mm	3050		

(Continued)

IMPLEMENT LIMITATIONS

No.	Implement	Remarks		M5091	M5111
15	Back hoe *2	Max. weight	kg	1200	
16	Snow blade	Max. width	mm	2430	2600
		Max. weight	kg	750	800

NOTE :

- Implement size may vary depending on soil operating conditions.

*1 Must remove front weight with this implement.

*2 Need subframe

*3 The value contains the weight of KUBOTA standard bucket.

OVERVIEW OF TRACTOR PARTS

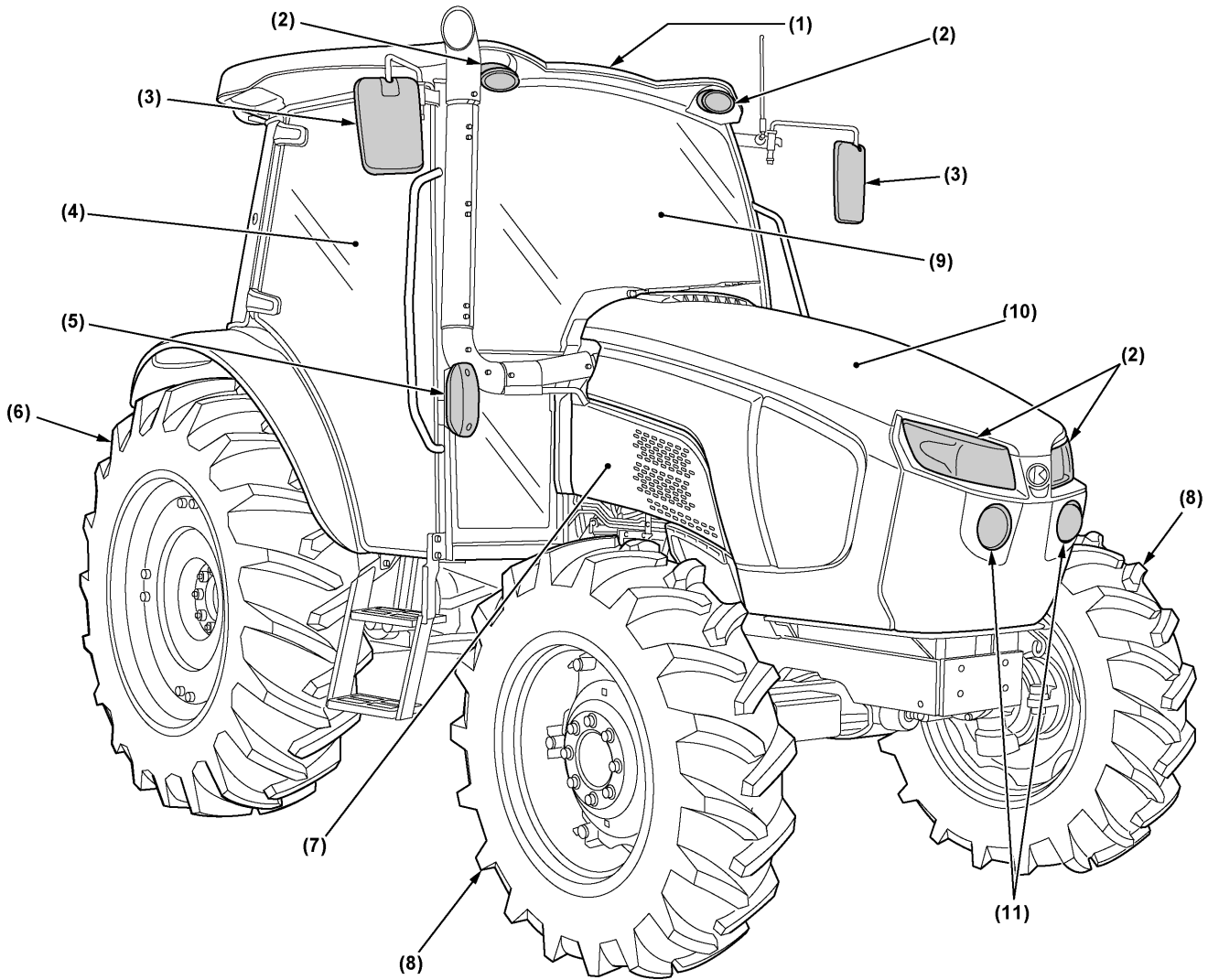

1MHJD00005D01

(1) CAB	96	(7) Side cover	110
(2) Front work light	98	(8) Front tire	91
(3) Rear-view mirror		(9) Windshield	
(4) Door	96	(10) Hood	110
(5) Position, turn signal and hazard lights	53	(11) Headlight	53
(6) Rear tire	91		

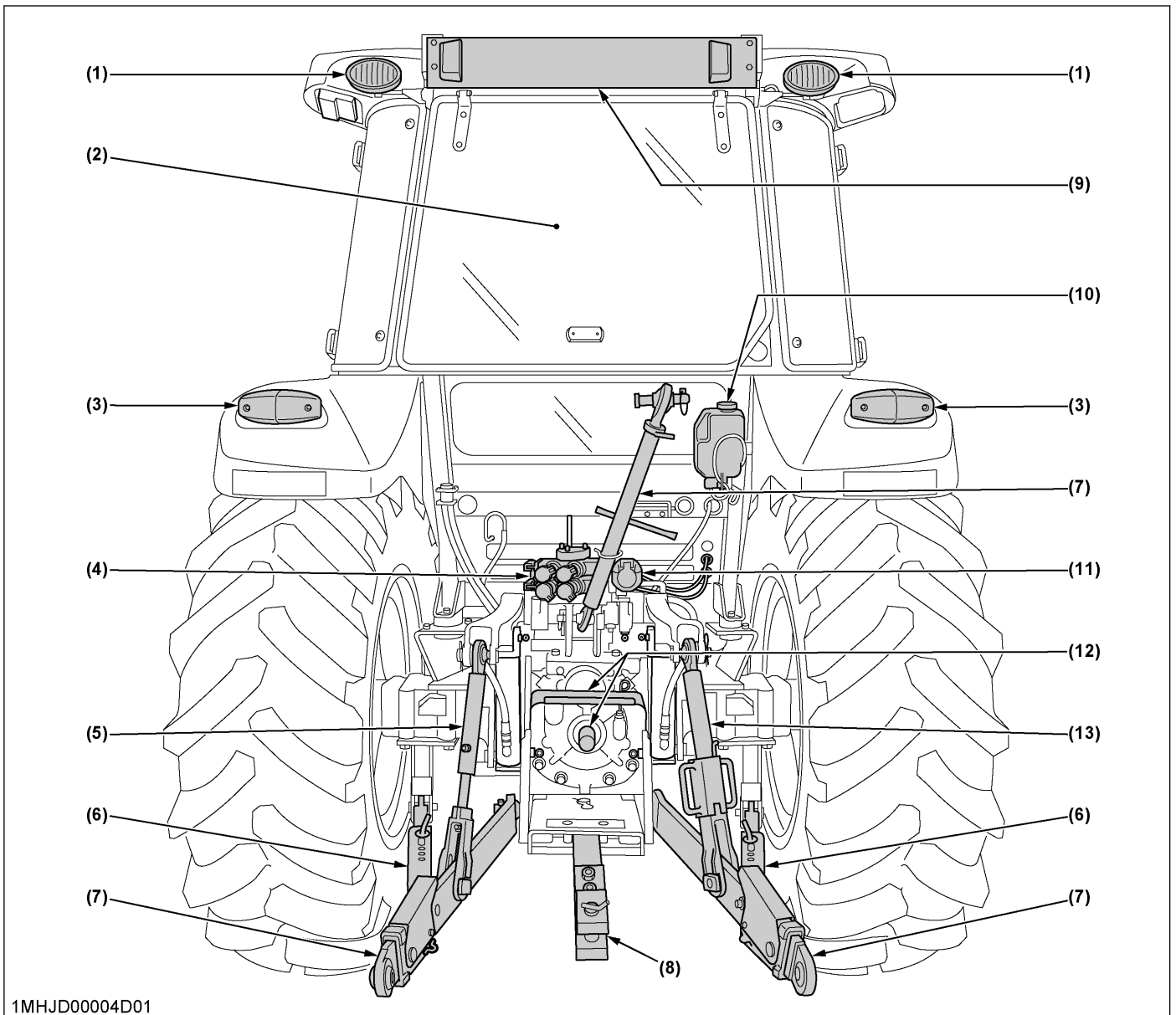

1MHJD00004D01

(1) Rear work light.....	98	(8) Drawbar.....	83
(2) Rear window.....	97	(9) Registration plate.....	73
(3) Stop, position, turn signal and hazard lights.....	53	(10) Washer liquid tank.....	138
(4) Remote control valve.....	86	(11) Trailer electrical outlet.....	74
(5) Lifting rod (left).....	80	(12) PTO shaft cover and shaft cap.....	76
(6) Telescopic stabilizer.....	81	(13) Lifting rod (right).....	80
(7) 3-point hitch.....	78		

INSTRUMENT PANEL AND CONTROLS

SWITCHES AND HAND CONTROLS

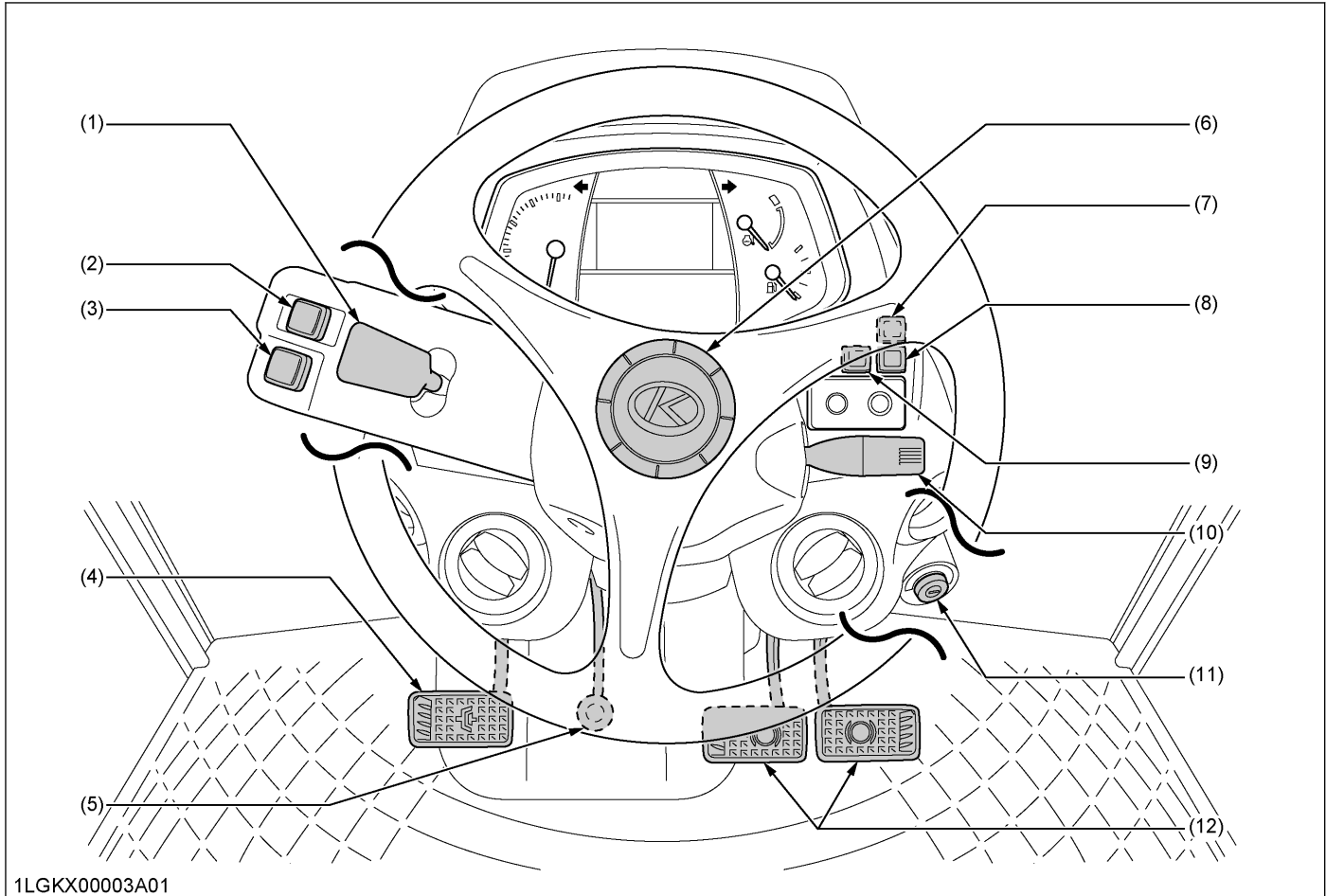

1LGKX00003A01

Illustrated contents

(1) Shuttle shift lever	58	(7) Constant RPM Management switch	70
(2) Auto differential lock switch	72	(8) DPF inhibit switch	40
(3) Hazard light switch	53	(9) Parked regeneration switch	42
(4) Clutch pedal	55	(10) Turn signal and headlight switch	53
(5) Steering wheel tilt pedal	52	(11) Key switch	
(6) Horn button	54	(12) Brake pedals	54

INSTRUMENT PANEL

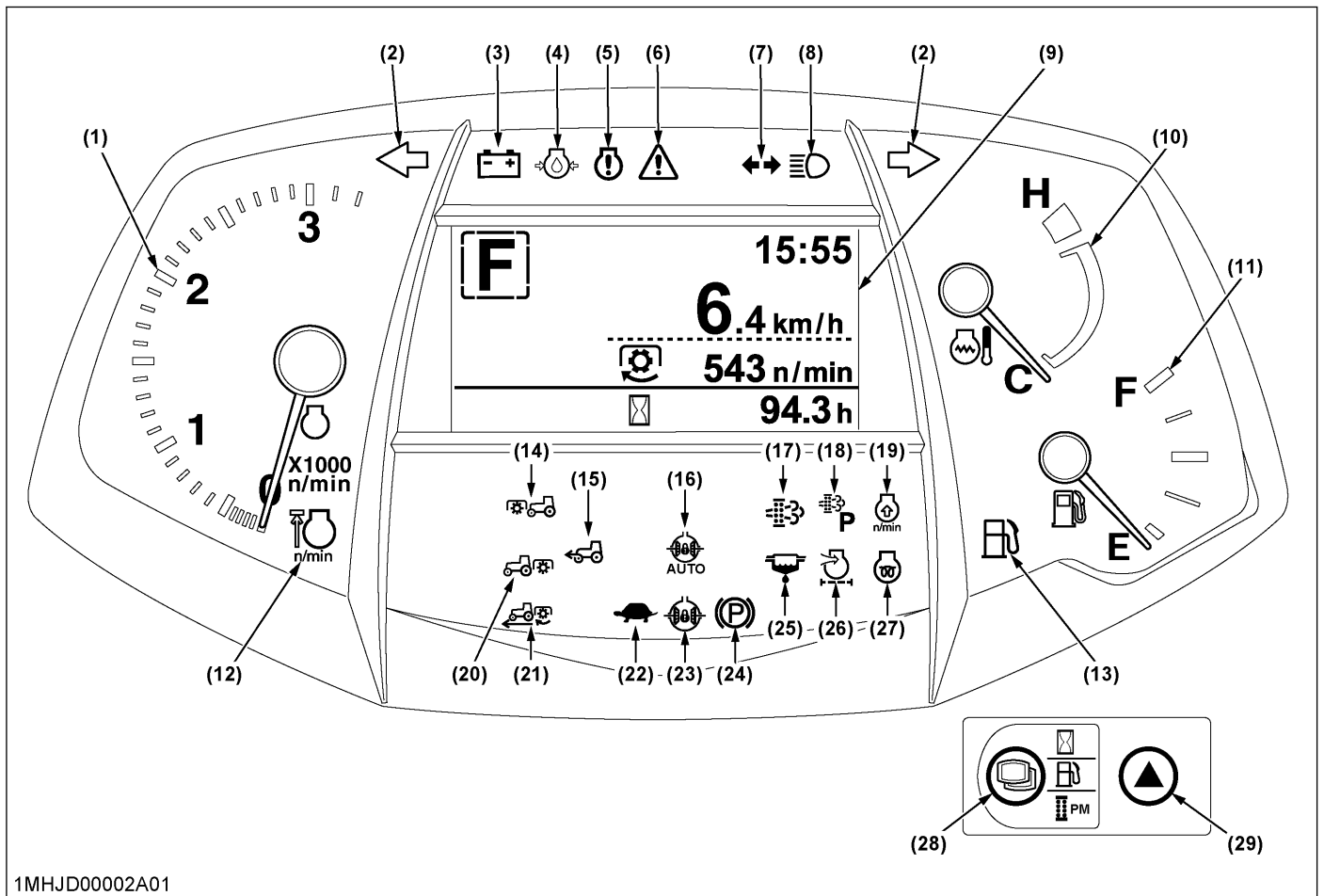

1MHJD00002A01

Illustrated contents

(1) Tachometer.....	63	(16) Auto differential lock indicator.....	72
(2) Hazard and turn signal indicator.....	53	(17) Regeneration indicator.....	38
(3) Electrical charge warning indicator.....	61	(18) Parked regeneration indicator.....	40
(4) Engine oil pressure warning indicator.....	61	(19) Engine rpm increase indicator.....	38
(5) Engine warning indicator.....	61	(20) Rear PTO indicator.....	45
(6) Master system warning indicator.....	61	(21) Ground PTO indicator (if equipped).....	
(7) Trailer indicator.....	54	(22) Dual speed shift indicator (if equipped).....	59
(8) High beam indicator.....	53	(23) Differential lock indicator.....	72
(9) Liquid crystal display (LCD).....	63	(24) Parking brake warning indicator.....	120
(10) Coolant temperature gauge.....	63	(25) Water separator indicator.....	61
(11) Fuel gauge.....	62	(26) Air cleaner indicator.....	61
(12) Rev-limiter indicator.....	58	(27) Heater indicator.....	45
(13) Fuel level indicator.....	61	(28) Mode selector switch.....	64
(14) Front PTO indicator (if equipped).....	60	(29) Select switch.....	64
(15) 4WD indicator.....	60		

FOOT AND HAND CONTROLS

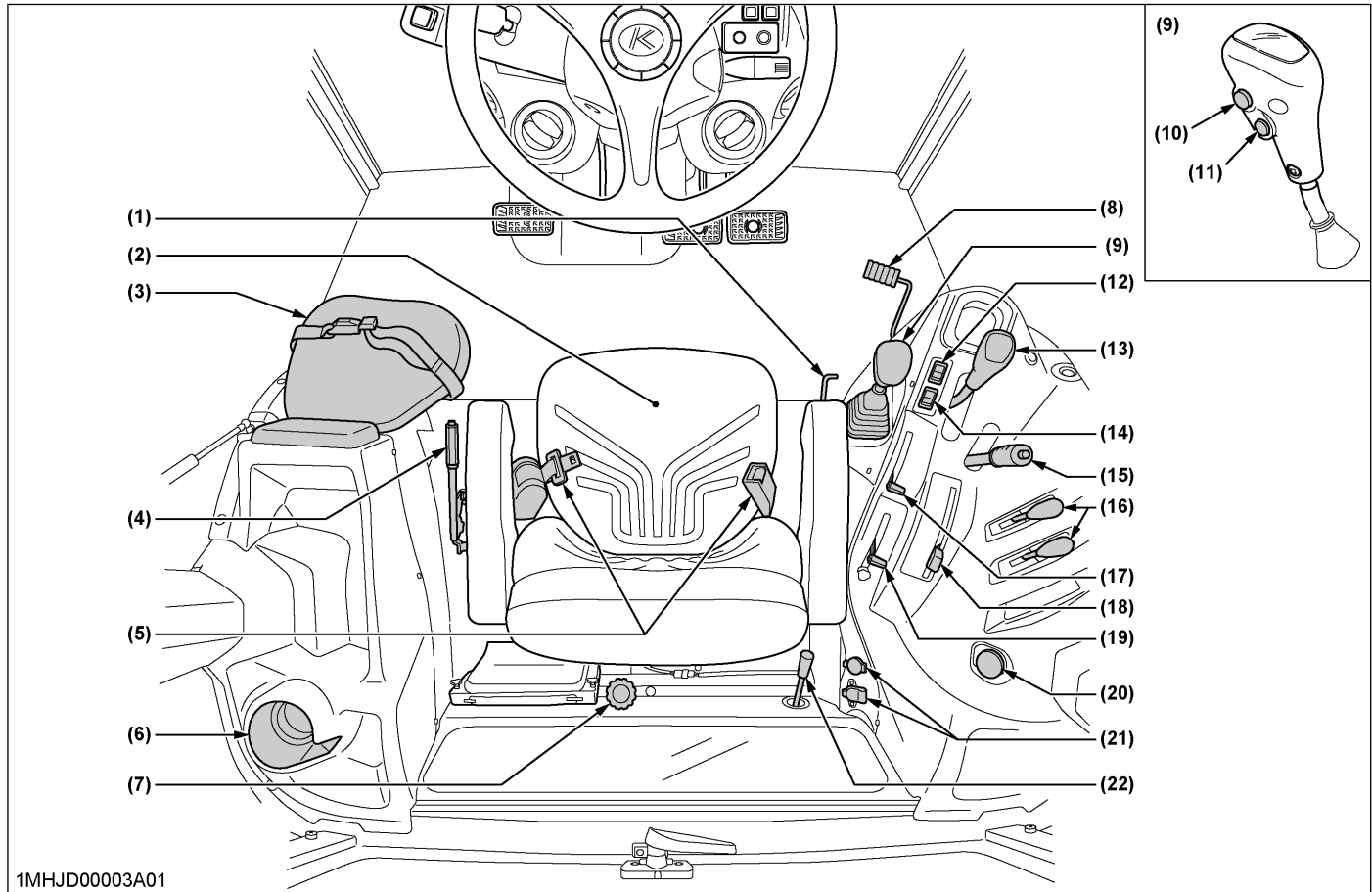

1MHJD00003A01

Illustrated contents

(1) Differential lock pedal	72	(12) RPM dual memory switch	69
(2) Operator's seat	49	(13) Range gear shift lever	58
(3) Instructional seat (if equipped)	50	(14) Front-wheel drive switch (4WD)	60
(4) Parking brake lever	55	(15) Gear-locked parking brake lever	55
(5) Seat belt	50	(16) Remote control valve lever	87
(6) Cup holder		(17) Hand throttle lever	60
(7) 3-Point hitch lowering speed knob	86	(18) Position control lever	85
(8) Foot throttle	60	(19) Draft control lever	85
(9) Main gear shift lever	58	(20) PTO clutch control switch	75
(10) Clutch-off switch (if equipped)	59	(21) Electrical outlet	103
(11) Dual speed shift switch (if equipped)	59	(22) PTO gear shift lever (if equipped)	76

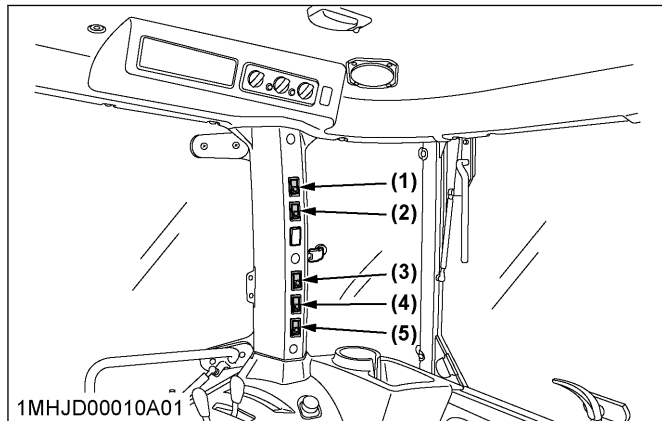

1MHJD00010A01

Illustrated contents

(1) Beacon light switch	103
(2) Front work light switch	98
(3) Rear work light switch	98
(4) Rear wiper and washer switch	99
(5) Front wiper and washer switch	99

PRE-OPERATION CHECK

DAILY CHECK

To prevent trouble from occurring, it is important to know the condition of the tractor. Check it before starting.



WARNING

To avoid personal injury or death:

- **Be sure to check and service the tractor on a level surface with the engine shut off, both parking brakes applied, and the implement lowered to the ground.**

Check item

- Walk around inspection
- Check engine oil level
- Check transmission oil level
- Check coolant level
- Check washer liquid level
- Check water separator
- Clean grill and radiator screen
- Clean air conditioner condenser
- Clean air conditioner condenser screen
- Clean intercooler (if equipped)
- Clean fuel cooler
- Clean oil cooler
- Check DPF muffler
- Check air cleaner evacuator valve (when used in a dusty place)
- Check brake pedal
- Check both parking brake levers
- Check indicators, gauges and meter
- Check lights
- Check seat belt
- Check movable parts
- Refuel
(See DAILY CHECK on page 111.)
- Care of the safety labels
(See SAFETY LABELS on page 14.)

OPERATING THE ENGINE

WARNING

To avoid personal injury or death:

- Read and understand the safe operation section.
- Read and understand the safety labels located on the tractor.
- To avoid the danger of exhaust fume poisoning, do not operate the engine in a closed building without proper ventilation.
- Never start the engine while standing on the ground. Start the engine only from operator's seat.
- Make it a rule to set all shift levers to the "NEUTRAL" positions and to place PTO clutch control switch in "OFF" position before starting the engine.

Details regarding safe operation can be found in a different section.

(See SAFE OPERATION on page 7.)

IMPORTANT :

- Do not use starting fluid or ether.
- To protect the battery and the starter, make sure that the starter is not continuously turned for more than 10 seconds.

EXHAUST AFTERTREATMENT DEVICES

WARNING

To avoid personal injury or death:

- During diesel particulate filter (DPF) regenerating operations, exhaust gases and exhaust filter components reach temperatures hot enough to burn people or ignite or melt common materials.
- Keep tractor away from people, animals or structures which may be susceptible to harm or damage from hot exhaust gases.
- During regeneration, white exhaust gases may be visible. Do not allow regeneration in an unventilated garage or confined area.
- During regeneration, do not leave the tractor.

DIESEL PARTICULATE FILTER (DPF) MUFFLER

This tractor is equipped with an engine with a diesel particulate filter (DPF) muffler which serves to reduce hydrocarbons, carbon monoxide and other toxic gases, all of which are contained in diesel engine emissions, to harmless carbon dioxide and water. The DPF also traps particulate matter (PM).

Please handle exhaust aftertreatment devices correctly and in an environmentally responsible manner.

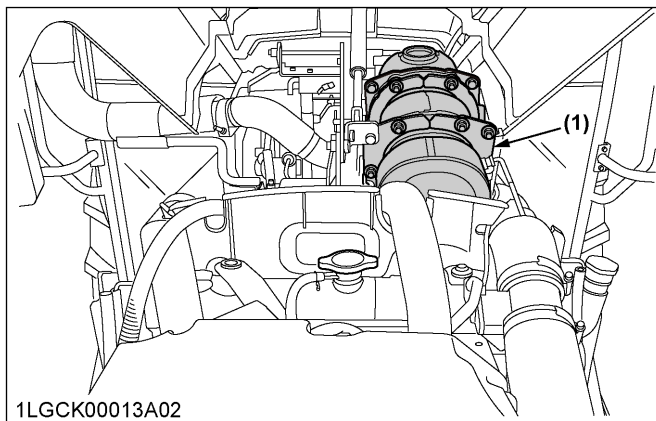

1LGCK00013A02

(1) Diesel particulate filter (DPF)

1. Handling points

When a specific amount of particulate matter (PM) has accumulated in the DPF muffler, it is necessary to refresh the DPF muffler by burning the PM inside it.

This burning off work is called "Regeneration".

To extend operating time to reach this regeneration, and to avoid DPF muffler trouble, make sure to observe the following handling matters.

Fuel

Be sure to use ultra-low sulfur fuel (S15).

IMPORTANT :

- Use of diesel fuel other than ultra-low sulfur fuel may adversely affect the engine and DPF performance.
Use of fuels other than ultra-low sulfur fuel (S15) may not meet regulations for your region.

Engine oil

Use DPF-compatible oil (CJ-4) for the engine.

IMPORTANT :

- If any engine oil other than CJ-4 is used, the DPF may become clogged earlier than expected and the fuel economy may drop.

Prohibition of unnecessary idling operation

Generally, the lower the engine speed, the lower the exhaust gas temperature is, so the PM contained in exhaust gas will not be burned, and begins to accumulate. Therefore, do not idle unnecessarily.

Regeneration

When there is “*Regeneration*” instruction sign by lamp or buzzer, immediately perform the required procedure for regeneration.

IMPORTANT :

- Interrupting the regeneration cycle or continuing operation while ignoring the warning signs may cause DPF and engine damage.

NOTE :

- If the engine is stopped once, the “*Auto regeneration*” mode will be activated.

2. DPF regeneration process

DPF regeneration process can be performed by choosing “*Auto regeneration*” or “*Regeneration inhibit*” mode according to your job conditions.

For jobs not affected by hot gases emitted during regeneration, “*Auto regeneration*” is advisable.

Auto regeneration mode

When starting the engine (switch operation is unnecessary), the “*Auto regeneration*” mode is automatically activated.

With the auto regeneration mode on, when a specific amount of PM has accumulated, and the regeneration conditions are satisfied, the DPF will be automatically regenerated whether the tractor is in motion or parked.

(See Tips on diesel particulate filter (DPF) regeneration on page 43.)

In this way, work efficiency is improved. For more details, read the “*Auto regeneration*” section of this manual.

(See Operating procedure for auto regeneration mode on page 38.)

Regeneration inhibit mode

After starting the engine, if the “*DPF inhibit switch*” is pressed to turn on the switch lamp, the “*Regeneration inhibit*” mode will be activated.

With “*Regeneration inhibit*” mode on, the PM which has accumulated inside the DPF will not be burned, unless the operator performs the regeneration work manually.

The “*Regeneration inhibit*” mode is effective for work in poorly ventilated workspaces.

For more details, read the regeneration prohibition section of this manual.

(See Operating procedure for regeneration inhibit mode on page 40.)

3. Operating procedure for auto regeneration mode

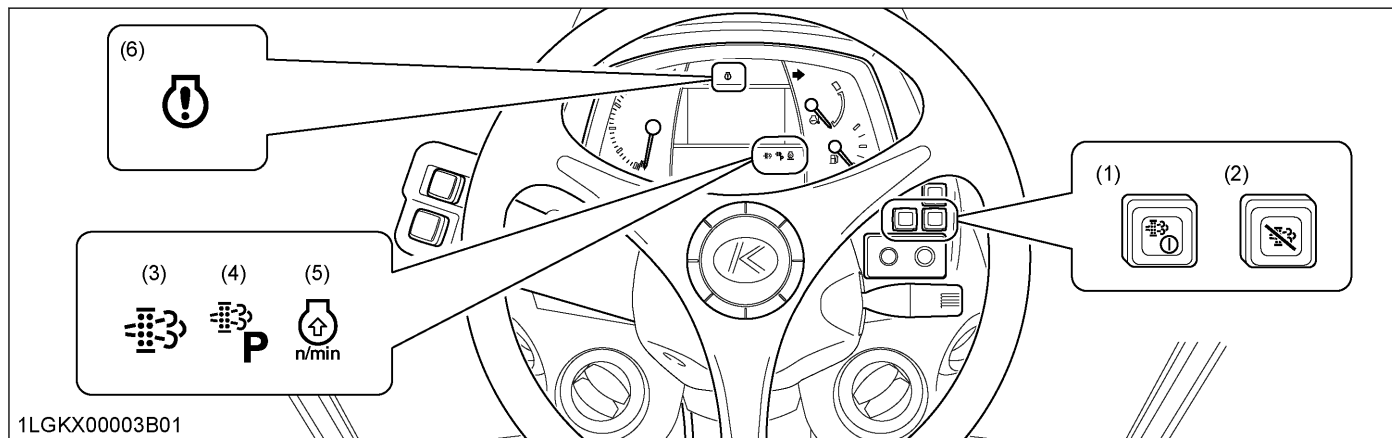

1LGKX00003B01

(1) Parked regeneration switch
(2) DPF inhibit switch

(3) Regeneration indicator
(4) Parked regeneration indicator

(5) Engine rpm increase indicator
(6) Engine warning indicator

Regeneration operating procedure

1. Start the engine.

Make sure that the DPF inhibit switch lamp  is "OFF".

Switch lamp "OFF": Auto regeneration mode activated.

Switch lamp "ON": Regeneration inhibit mode activated.

NOTE :

- When the engine is started, the "Auto regeneration" mode is automatically activated.
- "Regeneration inhibit" mode is activated when the DPF inhibit switch is pushed after the engine is started.

2. When the regeneration indicator  starts flashing:

A specific amount of PM has built up in the DPF.

Continue to operate the tractor, and the regeneration process will begin automatically; make sure the working place is in a safe area as DPF and exhaust temperature will rise.

3. When the engine rpm increase indicator  starts flashing:

Keep on working and increase the engine rpm until the indicator turns "OFF".

NOTE :

- Even if the auto regeneration mode is selected, DPF regeneration may not begin because system requirements have not been satisfied.
- The engine rpm increase indicator is used as a guide to satisfy the regeneration conditions. If the engine load is too heavy, the engine rpm increase indicator may continue to flash, even though regeneration system conditions are satisfied and regeneration may begin automatically.
(See Tips on diesel particulate filter (DPF) regeneration on page 43.)









3.1 PM warning level and required procedures

During auto regeneration mode when the PM level has built up in the DPF, the regeneration cycle will begin automatically.

If the regeneration cycle is interrupted or the regeneration conditions are not satisfied, the buzzer starts sounding and the indicator display changes in response to the PM level in order to prompt the operator to perform the required procedure listed in the following table.

IMPORTANT :

- **Once the regeneration level has been reached, immediately perform the required procedure for regeneration.**
Interrupting the regeneration cycle or continuing operation while ignoring the warning signs may cause DPF and engine damage.

Auto mode		
	DPF system status	Required procedure
PM warning level: 1 Buzzer: Not sounding	 The regeneration indicator starts flashing.  The rpm increase indicator starts flashing.  The regeneration indicator will stop flashing and remain "ON" constantly.	A specific amount of PM has accumulated in the DPF muffler. Continue to work the tractor to raise the DPF temperature. Continue the work and increase the engine rpm until the indicator turns "OFF". The regeneration cycle begins and continues until cycle is complete then the indicator will turn "OFF".
PM warning level: 2-1 Buzzer: Sounding every 5 seconds	If the regeneration cycle was interrupted or conditions are not satisfied for regeneration then DPF system is now in Level 2.  The regeneration indicator starts flashing.	Start the regeneration, referring to PM warning level: 1 above. Now the parked regeneration indicator starts flashing, and the parked regeneration can also be started. If the regeneration conditions are not met, perform the parked regeneration procedure. (See Operating procedure for parked regeneration on page 42.)
PM warning level: 2-2 Buzzer: Sounding every 3 seconds	 The rpm increase indicator starts flashing.  The parked regeneration indicator starts flashing.	
PM warning level: 3 Buzzer: Sounding every 1 second Engine output: 50%	If the regeneration fails in the warning level 2:  The engine warning indicator starts flashing.  The parked regeneration indicator starts flashing.	Immediately discontinue working the tractor and begin the parked regeneration cycle process. (See Operating procedure for parked regeneration on page 42.) At this PM warning level, the auto regeneration mode does not function. If the tractor is operated further, the regeneration cycle will be disabled.
PM warning level: 4 Buzzer: Sounding every 1 second Engine output: 50%	If the parked regeneration is interrupted or the tractor is continuously operated in the warning level 3:  The engine warning indicator remains constantly "ON".	Immediately move the tractor to a safe place, park it there and turn the engine "OFF". Contact your local KUBOTA Dealer. <ul style="list-style-type: none"> • At this level, do not continue to operate the tractor; otherwise, damage will result to the DPF and engine.

4. Operating procedure for regeneration inhibit mode

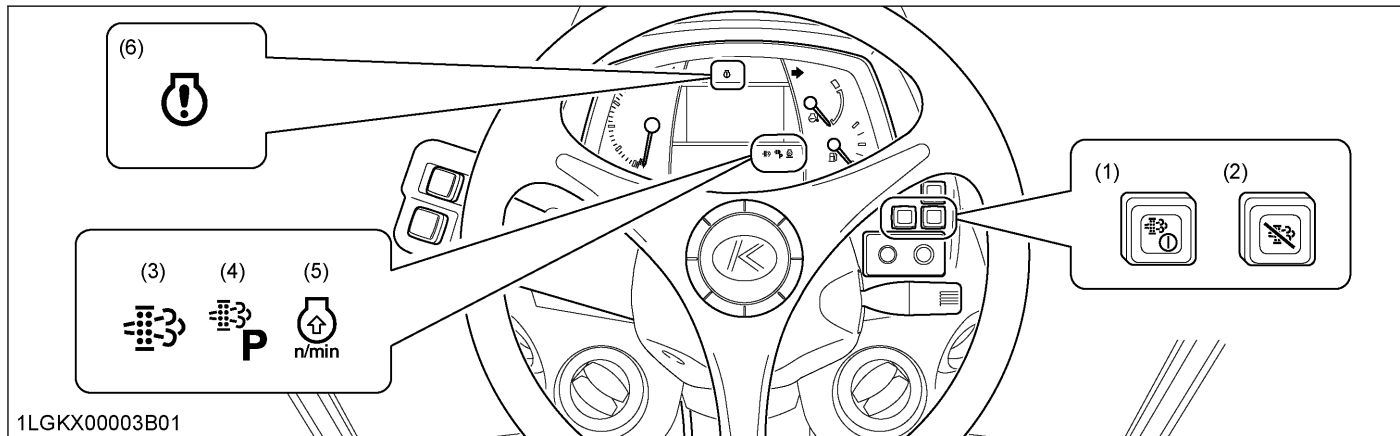

(1) Parked regeneration switch

(2) DPF inhibit switch

(3) Regeneration indicator

(4) Parked regeneration indicator

(5) Engine rpm increase indicator

(6) Engine warning indicator

Regeneration operating procedure

1. Start the engine.

2. Press the DPF inhibit switch , and the switch lamp illuminates.

Switch lamp "ON": Regeneration inhibit mode selected.

Switch lamp "OFF": Auto regeneration mode selected.

3. When the parked regeneration indicator  starts flashing:

A specific amount of PM has accumulated in the DPF muffler.

Move the tractor to a safe place and activate the DPF muffler.







(See Operating procedure for parked regeneration on page 42.)

4.1 PM warning level and required procedures



In the regeneration inhibit mode, the buzzer starts sounding and the indicator display changes in response to the PM level in order to prompt the operator to perform the required procedure listed in the following table.

IMPORTANT :

- **Once the regeneration level has been reached, immediately perform the required procedure for regeneration.**
Interrupting the regeneration cycle or continuing operation while ignoring the warning signs may cause DPF and engine damage.

Regeneration inhibit mode		
	DPF system status	Required procedure
PM warning level: 1 Buzzer: Not sounding	 The regeneration indicator starts flashing.	A specific level of PM has built up in the DPF muffler. Continue with the operation as it is.
	 At PM warning levels range from 1 to 2-2, it is also possible to change DPF inhibit switch to auto regeneration mode, then perform the regeneration.	
PM warning level: 2-1 Buzzer: Sounding every 5 seconds	 The regeneration indicator starts flashing.	Move the tractor to a safe area, then begin the parked regeneration cycle process. (See Operating procedure for parked regeneration on page 42.)
PM warning level: 2-2 Buzzer: Sounding every 3 seconds	 The parked regeneration indicator starts flashing.	
PM warning level: 3 Buzzer: Sounding every 1 second Engine output: 50%	If the parked regeneration cycle is interrupted or the tractor is continuously operated in the PM warning level 2:	
	 The engine warning indicator starts flashing.	Immediately stop working the tractor, move the tractor to a safe area, then begin the parked regeneration cycle process. (See Operating procedure for parked regeneration on page 42.) If the tractor is operated further and the operator ignores the warning signs, then regeneration will be disabled.
 The parked regeneration indicator starts flashing.		
PM warning level: 4 Buzzer: Sounding every 1 second Engine output: 50%	If the regeneration cycle is interrupted or the tractor is continuously operated ignoring the warning signs, in the PM warning level 3:	
	 The engine warning indicator remains constantly "ON".	Immediately move the tractor to a safe place, park it there and turn the engine "OFF". Contact your local KUBOTA Dealer. <ul style="list-style-type: none"> • At this level, do not continue to operate the tractor; otherwise, damage may result to the DPF and engine.

5. Operating procedure for parked regeneration

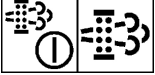
1. Park the tractor in a safe area away from buildings, people, and animals.
2. Apply both parking brakes.
3. Set the shuttle shift lever to the neutral position.
4. Turn "OFF" the PTO clutch control switch.
5. Return the engine rpm to the idle speed.
6. Lower the implement to the ground.
7. Press the DPF inhibit switch , and the switch lamp turns "OFF".
8. When the regeneration conditions are satisfied (2 to 5 and 7 mentioned previously), the parked regeneration switch lamp  starts flashing.
9. Press the parked regeneration switch  to start the regeneration cycle.
The switch lamp will stop flashing and remain "ON" constantly during the cycle.
10. The engine rpm will automatically rise, and the regeneration process will begin.
11. Both indicators  stay "ON" while regenerating the DPF.
They turn "OFF" when the cycle is complete.
12. After the lamp turns "OFF", normal tractor work may resume.
When driving in "Regeneration inhibit" mode, press the DPF inhibit switch to turn on the switch lamp.

NOTE :

- During the regeneration cycle, do not touch the above levers and switches (in steps 2, 3, 4), nor change the engine rpm other than for an emergency stop. Otherwise, the regeneration will be interrupted.
- Never leave the tractor when the parked regeneration process is activated.
- If the parked regeneration cycle is interrupted, the engine rpm is fixed at the idling level for about 30 seconds. For this period, keep the hand throttle lever and foot throttle pedal at the idle position. Do not move them. They will function again in 30 seconds.

6. Tips on diesel particulate filter (DPF) regeneration

• Operation

The higher in speed or load the engine operates, the higher the exhaust temperature rises. As a result, particulate matter (PM) inside the DPF is consumed and the regeneration process is required less frequently over time.

The lower in speed or load the engine operates, the lower the exhaust temperature. Accordingly, less particulate matter (PM) inside the DPF is consumed and more accumulation of PM will occur, which requires frequent regeneration. Therefore, avoid prolonged idling if possible.

• Necessary conditions for “Regeneration”

When the conditions below are all satisfied, regeneration will start. However, if even one condition is deviated from during the process, the regeneration will be interrupted.

- The engine coolant temperature.
- The DPF temperature.
- The engine speed is 1200 rpm or higher.

- Usually, it takes 15-20 minutes to complete the regeneration cycle.

Actual regeneration time may depend on ambient temperature, exhaust temperature and engine speed.

- It is recommended to do the regenerating while the engine is warm.
- Do not unnecessarily start and interrupt the regeneration process. Otherwise, a small amount of fuel becomes mixed with the engine oil, which degrades the oil quality.
- While the DPF is being regenerated, the engine air flow rate is automatically limited to keep up the exhaust temperature. Because of this, the engine may sound differently, but this is normal for this engine.
- Just after the regeneration has ended, the DPF muffler remains hot. It is advisable to keep the engine running for about 5 minutes to allow cooling of the exhaust components.

STARTING THE ENGINE

1. Make sure both the parking brake and the gear-locked parking brake are set.

NOTE :

- The parking brake warning indicator on the Easy Checker™ will turn on when a parking brake is set.

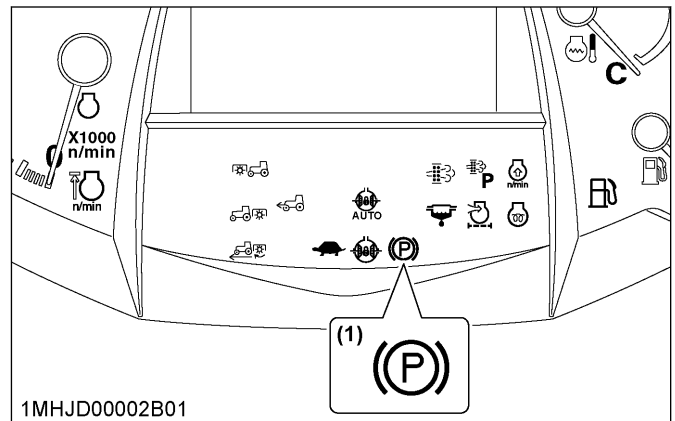

(1) Parking brake warning indicator

Applying the parking brake lever:

Pull the parking brake lever up to the parking position.

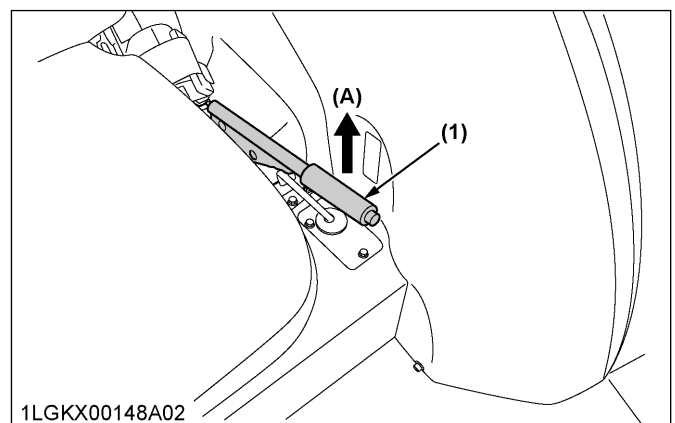

(1) Parking brake lever

(A) “Pull up to parking position”

IMPORTANT :

- If the tractor is operated with the parking brake set, the parking brake will be damaged.
- If the tractor is traveling when the parking brake lever is applied, a warning buzzer will sound.

If the buzzer sounds, immediately release the parking brake lever.

Applying the gear-locked parking brake lever:

Depress the brake pedals, place the main gear shift lever its neutral position, and pull the gear-locked parking brake lever to the parking position.

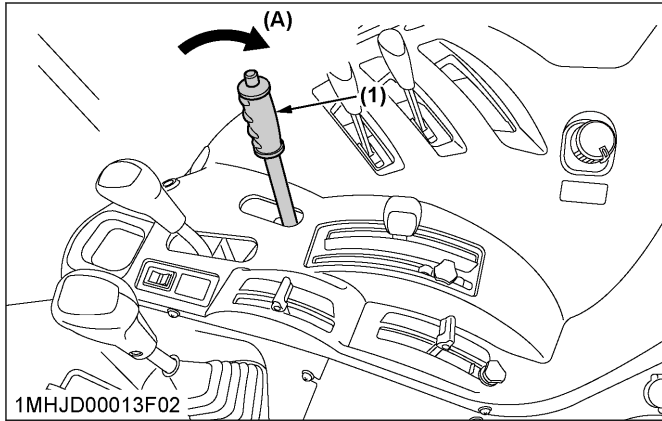

(1) Gear-locked parking brake lever (A) "Pull to parking position"

IMPORTANT :

- Bring the tractor to a complete stop before applying the gear-locked parking brake lever.

NOTE :

- In moving the gear-locked parking brake lever, you may feel it heavy sometimes, or light at other times. This is normal.

2. Make sure the fuel shutoff-valve is in the "OPEN" position.

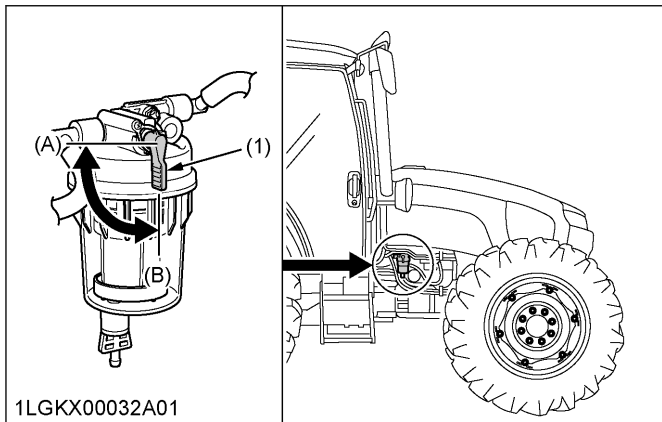

(1) Fuel shutoff-valve (A) "CLOSE" (B) "OPEN"

3. Place the shift levers in "NEUTRAL" position.

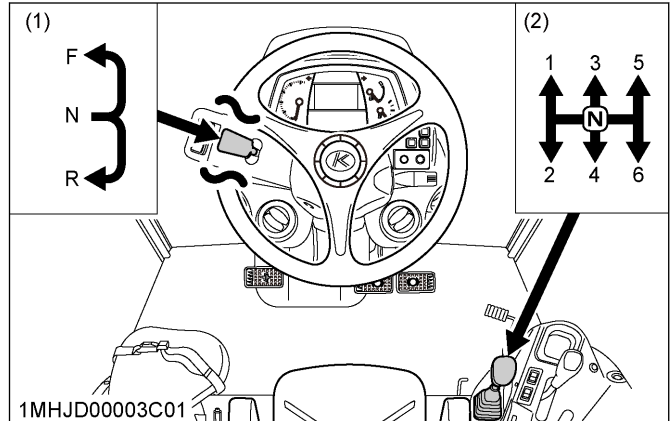

(1) Shuttle shift lever (F) "FORWARD" (N) "NEUTRAL POSITION" (R) "REVERSE"
(2) Main gear shift lever

4. Place the PTO clutch control switch in the "OFF" position and hydraulic control levers in the "LOWEST" position.

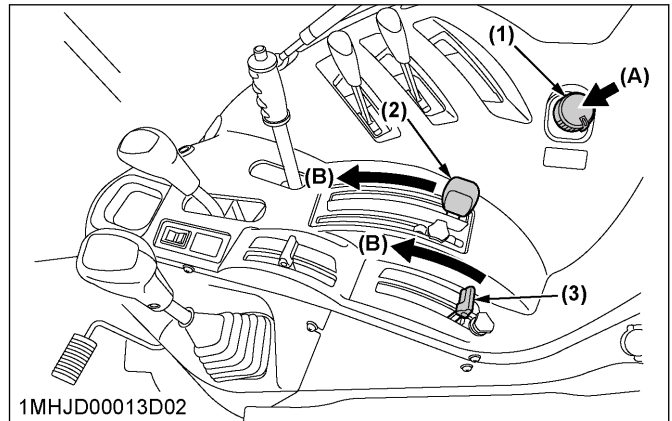

(1) PTO clutch control switch (A) "PUSH"
(2) Position control lever (B) "DOWN"
(3) Draft control lever

5. Set the throttle lever at the minimum speed position.

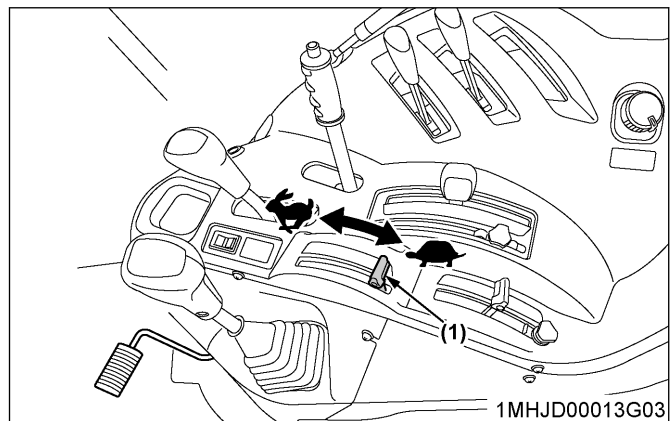

(1) Hand throttle lever "INCREASE" "DECREASE"

- Insert the key into the key switch and turn it "ON".
If the ambient temperature is below 0 °C and the engine is very cold, turn the key to "ON" position and hold it until the heater indicator turns off.

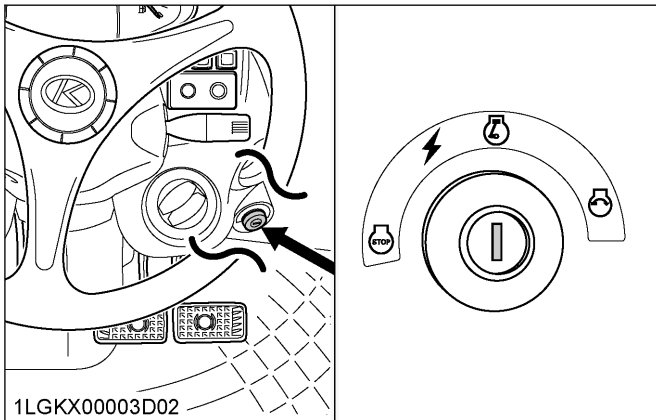

- "OFF" (Engine-stop)
- "ACC" (Electrical power-accessories)
- "ON" (Engine-run)
- "START" (Engine-start)

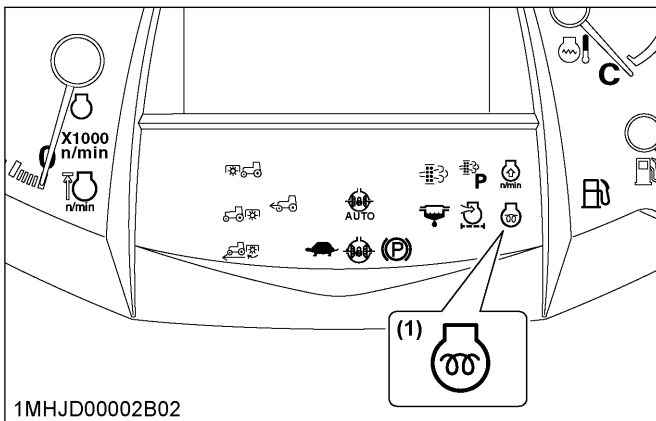

(1) Heater indicator

NOTE :

- The accessories can be used while the engine is stopped.
- Do not leave the key at "ACC" position. The battery will be quickly discharged. Turn it back to "OFF" after use.

- Check the Easy Checker™ indicators.
(See Checking Easy Checker™ indicators on page 45.)
- Fully depress the clutch pedal.
- Turn the key to "START" position and release when the engine starts.

IMPORTANT :

- Because of the safety devices, the engine will not start except when the PTO clutch control switch is placed in the "OFF" position and the shuttle shift lever is placed in the "NEUTRAL" position.

- If the engine fails to start after 10 seconds, turn off the key for 30 seconds. Then repeat steps 6 through 9. To protect the battery and the starter, make sure that the starter is not continuously turned for more than 10 seconds.

- Check to see that all the indicators on the Easy Checker™ are "OFF".
If an indicator is still on, immediately stop the engine and determine the cause.
- Release the clutch pedal.

1. Checking Easy Checker™ indicators

IMPORTANT :

- Daily checks with the Easy Checker™ only, are not sufficient. Never fail to conduct daily checks carefully by referring to the daily check.
(See DAILY CHECK on page 111.)

NOTE :

- Some of the Easy Checker™ indicators may illuminate or start flashing depending on the positions of the levers and switches.

- When the key is turned "ON", the electrical charge warning indicator and the engine oil pressure warning indicator should come on. If trouble should occur at any location while the engine is running, the indicator corresponding to problem will turn "ON".
- Suppose that the engine coolant temperature is not high enough yet. The heater indicator also turns "ON" when the key is turned "ON" to preheat the engine and goes off automatically when preheat is completed.
Illumination time of indicator varies according to the temperature of coolant.
- The PTO clutch indicator comes on while the PTO clutch control switch is engaged ("ON") and goes off when disengaged.
- If the fuel level indicator lights up, the fuel level is very low. Add fuel and the indicator will turn off.
- If the water separator indicator lights up, the water in the water separator is very high. Drain the water and the indicator will turn off.

- If the parking brake warning indicator (P) does not light up, set both parking brakes.

NOTE :

- The parking brake warning indicator (P) lights up if one of the parking brakes is applied. Even if the parking brake warning indicator (P) is already on, make sure that both parking brakes are set.

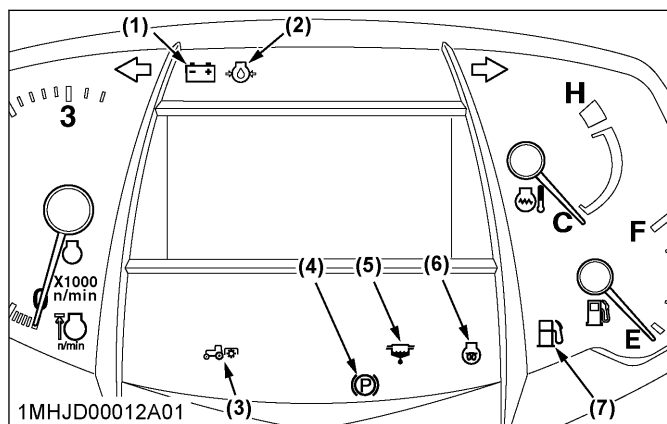

- Electrical charge warning indicator
- Engine oil pressure warning indicator
- Rear PTO indicator
- Parking brake warning indicator
- Water separator indicator
- Heater indicator
- Fuel level indicator

OPERATING THE ENGINE IN FREEZING CONDITIONS

1. Block heater (if equipped)

A block heater is available as an option from your dealer. It will assist you in starting your tractor when the ambient temperature is below -20 °C.

STOPPING THE ENGINE

- After slowing the engine to idle, wait 3 to 5 minutes for the turbo to slow down and then turn the key to "OFF".
- Remove the key.

NOTE :

- If removing the key does not stop the engine, consult your local KUBOTA Dealer.

WARMING UP THE ENGINE

! WARNING

To avoid personal injury or death:

- Be sure to set both parking brakes during warm-up.

- Be sure to set all shift levers to the "NEUTRAL" positions and to place PTO clutch control switch in "OFF" position during warm-up.

For 5 minutes after engine start-up, allow the engine to warm up without applying any load; this is to allow oil to reach every engine part. If load should be applied to the engine without this warm-up period, trouble such as seizure, breakage or premature wear may develop.

1. Warm-up and transmission fluid at low temperature range

Hydraulic oil serves as transmission fluid. In cold weather, the oil may be cold with increased viscosity. This can cause delayed oil circulation or abnormally low hydraulic pressure for some time after engine start-up. This, in turn, can result in trouble in the hydraulic system.

To prevent the above, observe the following instructions:

Warm up the engine at about 50% of rated rpm according to the following table:

Ambient temperature	Warm-up time requirement
Higher than 0 °C	Approx. 5 minutes
0 to -10 °C	10 to 20 minutes
-10 to -20 °C	20 to 30 minutes
Below -20 °C	More than 30 minutes

IMPORTANT :

- Do not operate the tractor under full load condition until it is sufficiently warmed up.

JUMP STARTING

! WARNING

To avoid personal injury or death:

- Battery gases can explode. Keep cigarettes, sparks, and flames away from the battery.
- If the tractor battery is frozen, do not jump start engine.
- Do not connect the other end of the negative (-) jumper cable to the negative (-) terminal of the tractor battery.
- When taking out the dead battery, putting in the battery or fixing the battery, do not allow the positive (+) terminal of the battery to touch other parts.

When jump starting the engine, follow the instructions below to safely start the engine.

1. Bring the helper vehicle with a battery of the same voltage as the disabled tractor within easy cable reach.

IMPORTANT :

- **The vehicles must not touch.**

2. Engage the parking brakes of both vehicles and put the shift levers in neutral. Shut both engines off.
3. Wear eye protection and rubber gloves.
4. Attach the red clamp to the positive (red, (+) or positive) terminal of the dead battery and clamp the other end of the same cable to the positive (red, (+) or positive) terminal of the helper battery.
5. Clamp the other cable to the negative (black, (-) or negative) terminal of the helper battery.
6. Clamp the other end to the engine block or frame of the disabled tractor as far from the dead battery as possible.
7. Start the helper vehicle and let its engine run for a few moments. Start the disabled tractor.
8. Disconnect the jumper cables in the exact reverse order of attachment (steps 6, 5 and 4).

Connect cables in numerical order.

Disconnect in reverse order after use.

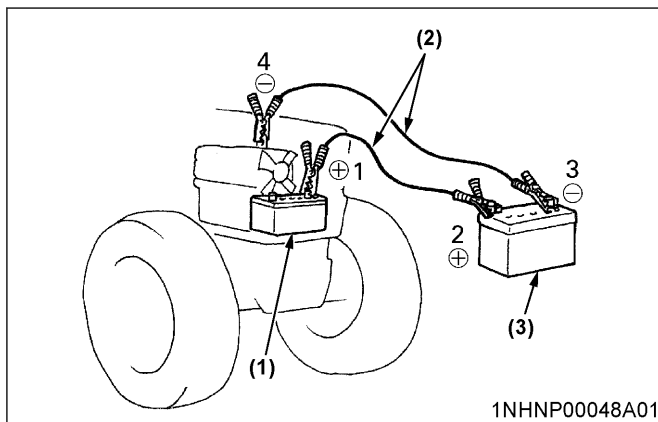

- (1) Dead battery
 (2) Jumper cables
 (3) Helper battery

IMPORTANT :

- **This tractor has a 12 volt negative (-) ground starting system.**
- **Use only the same voltage for jump starting.**
- **Use of a higher voltage source on tractor's electrical system could result in severe damage to tractor's electrical system. Use only matching voltage source when "Jump starting" a low or dead battery condition.**
- **Do not operate the tractor with the battery cable disconnected from the battery.**

- **Do not operate the tractor without the battery mounted.**
- **Do not operate the tractor with the battery dead. Charge the battery fully before operating the tractor. Otherwise, the tractor might malfunction.**

OPERATING THE TRACTOR

OPERATING NEW TRACTOR

How a new tractor is handled and maintained determines the life of the tractor.

A new tractor just off the factory production line has been, of course, tested, but the various parts are not accustomed to each other, so care should be taken to operate the tractor for the first 50 hours at a slower speed and avoid excessive work or operation until the various parts become "*broken-in*". The manner in which the tractor is handled during the "*breaking-in*" period greatly affects the life of your tractor.

Therefore, to obtain the maximum performance and the longest life of the tractor, it is very important to properly break-in your tractor. In handling a new tractor, the following precautions should be observed.

1. Do not operate the tractor at full speed for the first 50 hours

- Do not start quickly nor apply the brakes suddenly.
- In winter, operate the tractor after fully warming up the engine.
- Do not run the engine at speeds faster than necessary.
- On rough roads, slow down to suitable speeds. Do not operate the tractor at high speed.

The above precautions are not limited only to new tractors, but to all tractors. However, they should be especially observed in the case of new tractors.

2. Changing lubricating oil for new tractors

The lubricating oil is especially important in the case of a new tractor. The various parts are not "*broken-in*" and are not accustomed to each other. Small metal grit may develop during the operation of the tractor, and this may wear out or damage the parts. Therefore, care should be taken to change the lubricating oil a little earlier than would ordinarily be required.

For more details, read the maintenance section of this manual.

(See MAINTENANCE on page 105.)

BOARDING AND LEAVING THE TRACTOR

- Never try to get on or off a moving tractor or jump off the tractor to exit.

- Face the tractor when getting into or out of the tractor. Do not use the controls as handholds to prevent inadvertent machine movements.
- Always keep steps and floor clean to avoid slippery conditions.

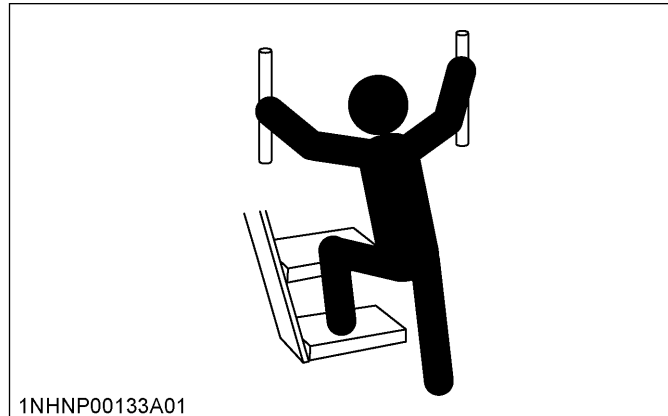

STARTING THE TRACTOR

1. Adjusting the operator's position.

NOTE :

- **The seat and suspension should be adjusted to ensure that the controls are comfortably at hand for the operator, ensuring that the operator maintains a good posture and minimizes risks from whole body vibration.**

- Operator's seat on page 49
 - Seat belt on page 50
 - Instructional seat (if equipped) on page 50
 - Tilt steering adjustment on page 52
2. Selecting light switch position.
 - Light switch on page 53
 - Turn signal switch and hazard light switch on page 53
 - With trailer connector on page 54
 3. Checking the brake pedal.
 - Brake pedals (right and left) on page 54
 4. Pull the position control lever to raise the implement.
 - Position control on page 85

5. Depress the brake pedals and release both parking brake levers.

NOTE :

- The parking brake warning indicator on the Easy Checker™ will turn off when both parking brakes are released.

- Parking brake lever
- Gear-locked parking brake lever on page 55

6. Depress the clutch pedal.
 - Clutch pedal on page 55
7. Selecting the travel speed.
 - Travel speed control on page 57
 - Travel speed limiter on page 58
 - Main gear shift lever on page 58
 - Range gear shift lever on page 58
 - Creep speed on page 58
 - Shuttle shift lever on page 58
 - Dual speed shift switch (if equipped) on page 59
 - Clutch-off switch (if equipped) on page 59
 - 4WD switch on page 60
8. Accelerate the engine.
 - Hand throttle lever on page 60
 - Foot throttle on page 60
9. Unlock the brake pedals and slowly release the clutch.

1. Operator's seat

**WARNING**

To avoid personal injury or death:

- Make adjustments to the seat only while the tractor is stopped.
- Make sure that the seat is completely secured after each adjustment.
- Do not allow any person other than the operator to ride on the tractor.

IMPORTANT :

- After adjusting the operator's seat, be sure to check to see that the seat is properly locked.

1.1 Mechanical suspension seat

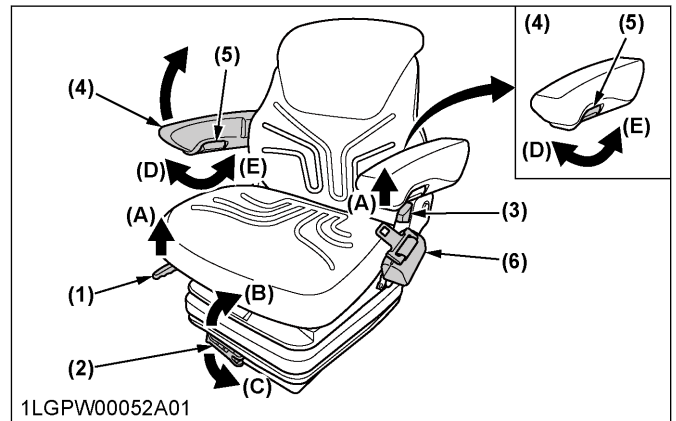

- | | |
|--------------------------------|---------------------------|
| (1) Travel adjust lever | (A) "UNLOCK" |
| (2) Weight adjust lever | (B) "TO INCREASE TENSION" |
| (3) Backrest tilt adjust lever | (C) "TO DECREASE TENSION" |
| (4) Armrest | (D) "TO INCREASE ANGLE" |
| (5) Armrest angle adjust knob | (E) "TO DECREASE ANGLE" |
| (6) Seat belt retractor | |

Travel adjustment

Unlock the travel adjust lever and slide the seat backward or forward, as required. The seat will lock in position when the lever is released.

Weight adjustment

Turn the weight adjust lever to achieve the optimum suspension setting.

Height adjustment

Pull up with your hands the seat pan to the desired height of the 3 available positions.

Once it has reached the highest level, it will return to the lowest level.

Tilt adjustment

Pull the backrest tilt adjust lever and tilt the backrest to the desired position.

Armrest

Armrest may be set at its upright position if desired.

Armrest angle adjustment

Turn the armrest angle adjust knob to the desired angle.

1.2 Air suspension seat (if equipped)

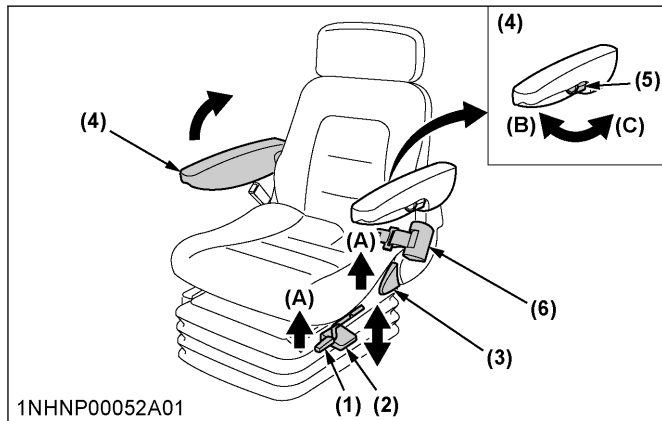

- (1) Travel adjust lever
- (2) Weight and height adjust lever
- (3) Backrest tilt adjust lever
- (4) Armrest
- (5) Armrest angle adjust knob
- (6) Seat belt retractor
- (A) "UNLOCK"
- (B) "TO INCREASE ANGLE"
- (C) "TO DECREASE ANGLE"

Travel adjustment

Unlock the travel adjust lever and slide the seat backward or forward, as required. The seat will lock in position when the lever is released.

Weight and height adjustment

Turn on the key switch. The seat should be adjusted for the operator's weight by briefly pulling up or pushing down the weight and height adjust lever with the tractor in a stationary position and the operator sitting on the seat.

The seat can be adjusted in its adjustable range.

IMPORTANT :

- In order to avoid damage of the seat, do not operate the weight and height adjust lever for more than 1 minute.

Tilt adjustment

Pull the backrest tilt adjust lever and tilt the backrest to the desired position.

Armrest

Armrest may be set at its upright position if desired.

Armrest angle adjustment

Turn the armrest angle adjust knob to the desired angle.

2. Seat belt

WARNING

To avoid personal injury or death:

- Always use the seat belt when a ROPS or CAB is installed.

Adjust the seat belt for proper fit and connect the buckle. This seat belt is auto-locking retractable type.

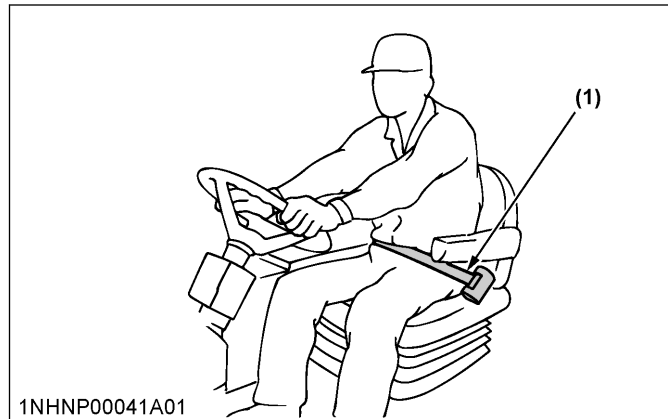

(1) Seat belt

3. Instructional seat (if equipped)

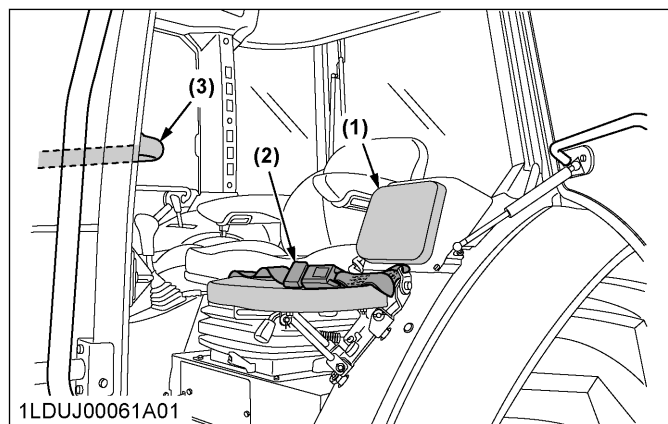

(1) Instructional seat
(2) Seat belt
(3) Handrail

Intended use

The instructional seat is intended for training purposes. A tractor instructor, a trainee or a servicing staffer is supposed to use this seat of CAB-equipped tractors on flat, safe grounds, where the potential for roll-over is practically zero. Do not drive the tractor along expressways and public ways.

Understanding the previously mentioned purposes, do not use this seat under any other conditions than specified.

The conditions which show as examples not to use this seat are as follows.

- Do not allow any other persons and animals than the instructor, the trainee or servicing staffer on this seat. Never allow children to sit down on this seat. Do not place anything on this seat for transport purpose.
- Use this seat only for training purpose, not for anything else.
- Never use this seat on any locations where the machine might turn over. Never operate the machine prone to turn over, either. Slopes, rough terrains, high-speed running, sharp turns, towing, sudden starting, stopping and so on.

- Do not use this seat whenever the operator's view is affected by bad weather (such as rain and fog) or in the late afternoon.

! WARNING

To avoid personal injury or death:

- Always wear your seat belt and stabilize your body by holding the handrail on the CAB frame.
- It is not intended to carry children nor any other person for any other purposes.
- The left-hand door must be closed at all time whenever the instructional seat is occupied and the tractor is in motion.
- Do not permit others to ride, except on the designated instructional seat.
- Use caution to avoid the risks of obstructing operator's view, falling from the machine and interfering with controls.
- Do not start and stop the tractor suddenly, nor take a sharp turn.
- Do not use the instructional seat if the seat belt or the door lock fails to function.
- Do not use the instructional seat for transport.
- When opening or closing the door while being seated in the instructional seat, move the door slowly. This is to prevent his or her hand(s) from getting caught by the door or his or her body to hit against the door.

3.1 Precautions in using the instructional seat

When getting on the tractor

- The operator is supposed to move the tractor onto a flat surface and to apply both parking brakes for a complete stop.
- The passenger is supposed to stand on the ground and to set up the seat. Before use, make sure the seat is securely fixed.

Procedure to set up

- Lift up the seat (1) until the rod (2) is fixed to the fixing bracket (3).
- Press down on the seat to make sure it is securely fixed.

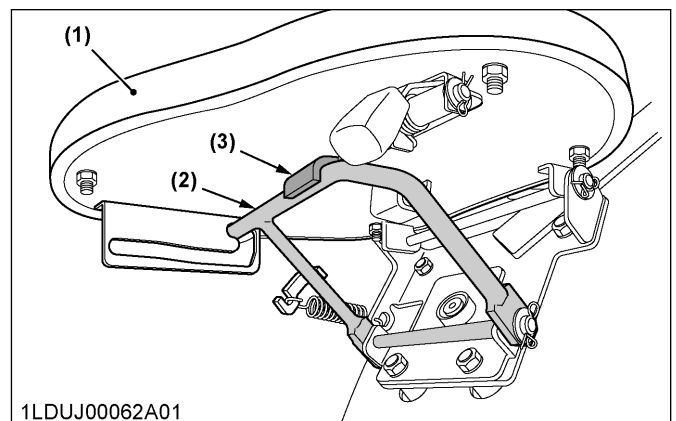
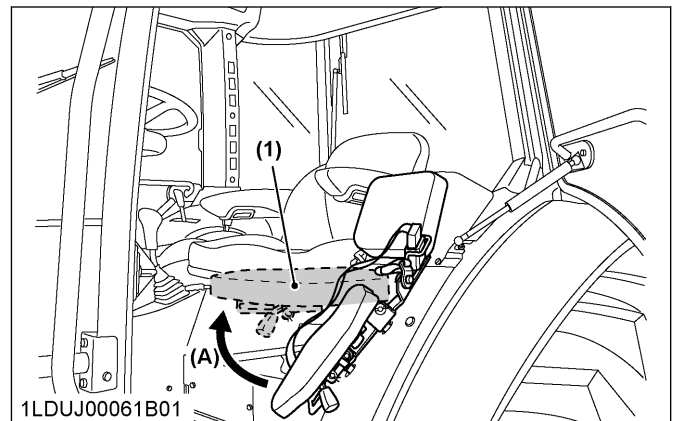

(1) Seat
(2) Rod
(3) Fixing bracket
(A) Lift up

Get on the tractor. In getting on the tractor, stabilize yourself by holding the specified handrail with attention not to get in contact with any control levers.

- Fasten the seat belt and close the door. Then get the door locked.

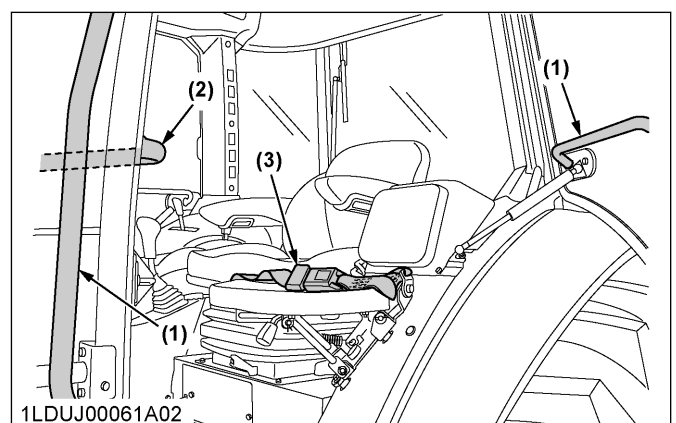

(1) Handrail (climbing)
(2) Handrail (sitting)
(3) Seat belt

While the machine is in motion

- The person on the instructional seat should take due care not to interfere with the operator's actions.

2. While sitting, be sure to keep the seat belt fastened. The person on the instructional seat is supposed to grip the handrail to prevent him or her from getting out of balance due to violent machine movements.
3. Run the tractor at low speed.

When getting off the tractor

1. The operator is supposed to move the tractor onto a flat surface and to apply both parking brakes for a complete stop.
2. The person on the instructional seat is supposed to open the door, unfasten the seat belt and get out of the tractor.
3. Recouple the left and right halves of the seat belt and store it in the holder because otherwise there is a risk of damage to the door.

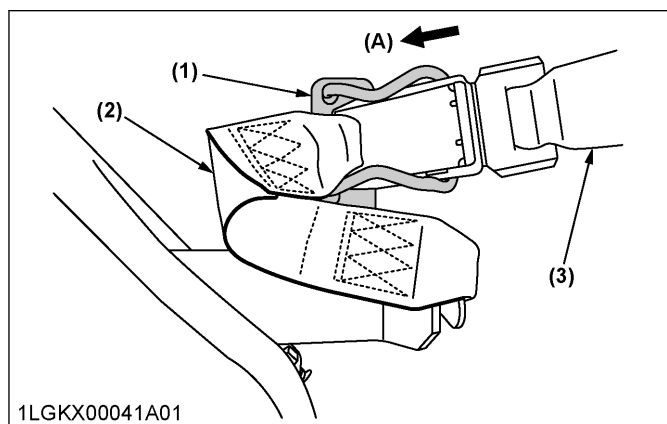

1LGKX00041A01
 (1) Seat belt holder (A) Insert
 (2) Seat belt LH
 (3) Seat belt RH

4. Store the instructional seat with care not to get your fingers caught by the linking parts. Finally, close the door.

Procedure to store

1. Pull up the release lever with the front of the seat slightly tilted up.

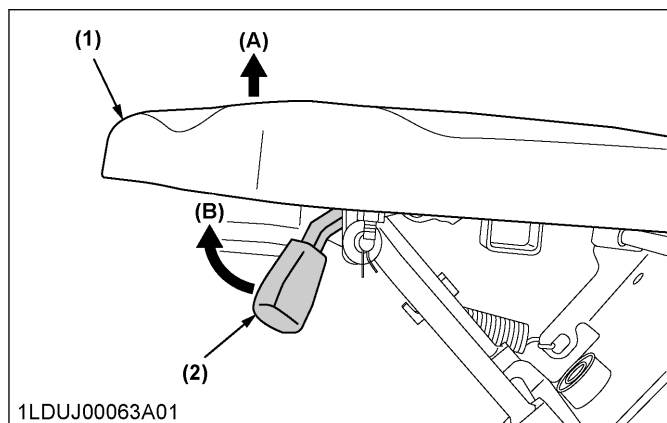

1LDUJ00063A01
 (1) Seat (A) "Lift a little bit"
 (2) Lever (B) "Pull up"

2. Release the rod from the fixing bracket, and the seat moves downwards.

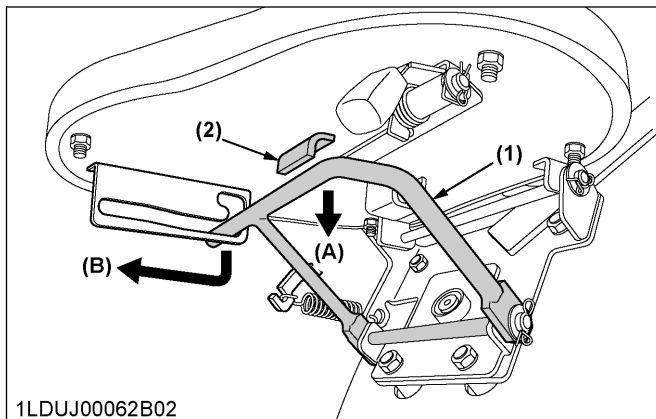

1LDUJ00062B02
 (1) Rod (A) "Release"
 (2) Fixing bracket (B) "Moves in this direction"

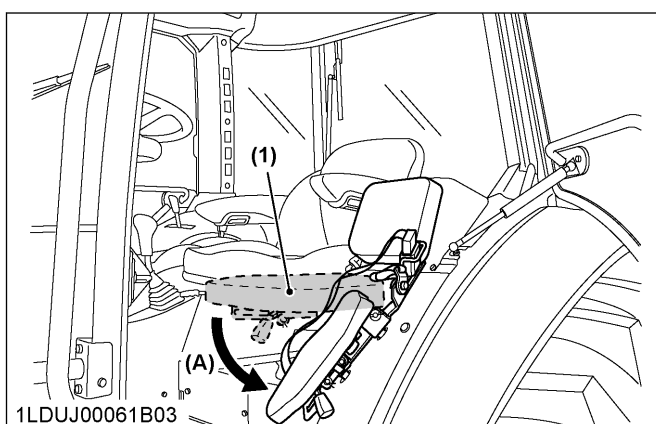

1LDUJ00061B03
 (1) Seat (A) "Moves downward"

NOTE :

- The instructional seat can be used only when permitted by your local laws. Consult your local KUBOTA Dealer for further details.

4. Tilt steering adjustment

CAUTION
 To avoid personal injury:
 • Do not adjust the steering wheel while the tractor is in motion.

Press down the steering wheel tilt pedal, to release the lock so the steering wheel can be adjusted to the desired position.

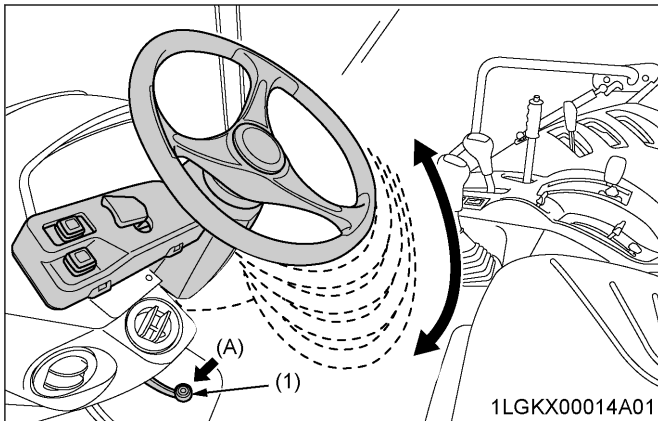

(1) Steering wheel tilt pedal (A) "PRESS DOWN"

5. Light switch

Turn the light switch clockwise, and the following lights are activated on the switch position.

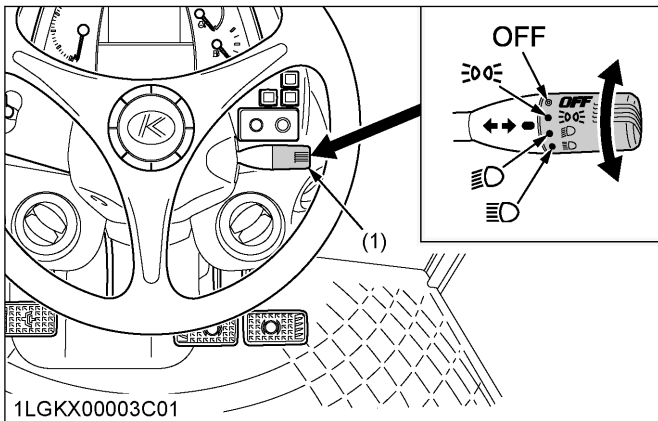

(1) Headlight switch

- OFF** Headlights OFF.
- Position lights ON.
- Headlights dimmed, low beam. Tail lights ON.
- Headlights ON, high beam. Tail light ON.

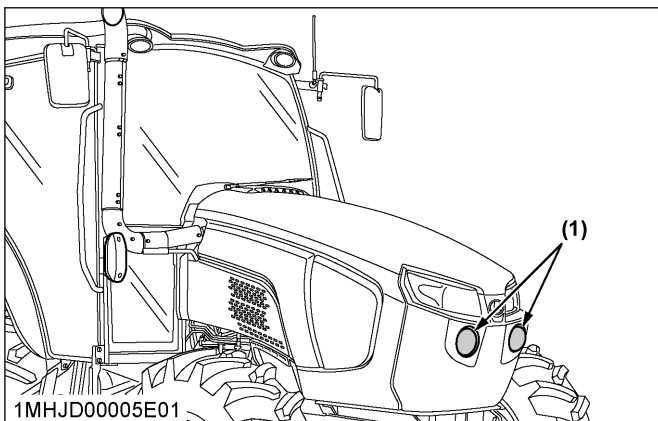

(1) Headlight

6. Turn signal switch and hazard light switch

Hazard light

1. When the hazard light switch is pushed, the hazard lights flash, along with the LH and RH indicators on the instrument panel.
2. Push the hazard light switch again to turn off the hazard lights.

Turn signal light

To indicate a right turn, turn the turn signal light switch clockwise. To indicate a left turn, turn the turn signal light switch counter-clockwise. The corresponding right and left turn signal lights and indicator on the instrument panel will flash.

NOTE :

- The hazard light switch is operative when the key switch is in the "ON", "ACC" or "OFF" position.
- The turn signal light switch is only operative when the key switch is in the "ON" position.
- Be sure to return the turn signal switch to its center position after turning.

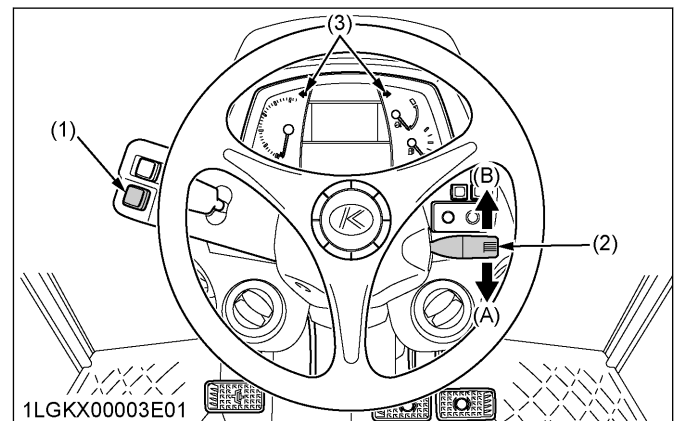

(1) Hazard light switch (A) "RIGHT TURN"
 (2) Turn signal light switch (B) "LEFT TURN"
 (3) Hazard and turn signal indicator

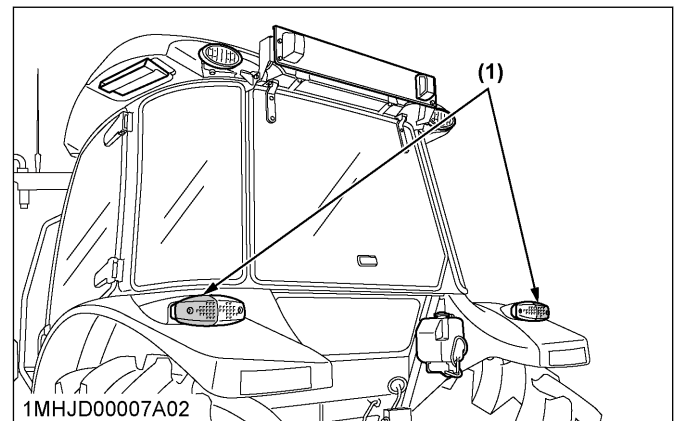

(1) Turn signal and hazard light

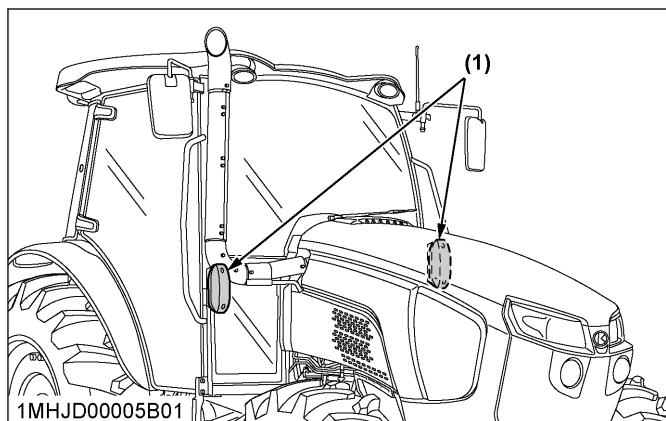

(1) Turn signal and hazard light

6.1 With trailer connector

When you operate the turn signal light switch with the trailer power connector connected, the trailer indicator in the instrumental panel also starts flashing along with the turn signal indicator.

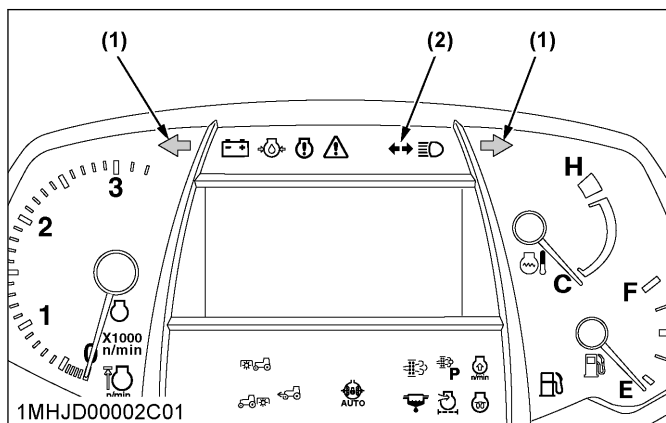

(1) Hazard and turn signal indicator
(2) Trailer indicator

7. Horn button

The horn will sound when the key switch is in "ON" position and horn button is pushed.

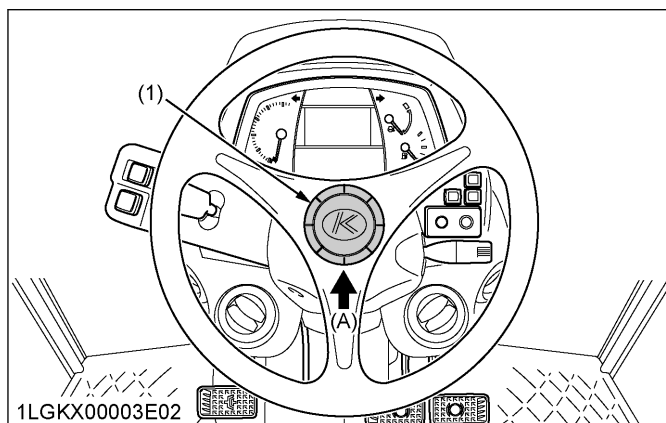

(1) Horn button (A) "PUSH"

8. Brake pedals (right and left)

⚠ WARNING

To avoid personal injury or death:

- Be sure to interlock the right and left pedals. Applying only one rear wheel brake at high speeds could cause the tractor to swerve or roll-over.
- Be sure brake pedals have equal adjustment when using locked together. Incorrect or unequal brake pedal adjustment can cause the tractor to swerve or roll-over.
- Be aware of the enhanced braking characteristics of the 4-wheel braking system. Appropriate care should be taken during hard braking and/or when pulling towed loads.
- Do not brake suddenly. An accident may occur as a result of a heavy towed load shifting forward or loss of control.
- To avoid skidding and loss of steering control when driving on icy, wet, or loose surfaces, make sure the tractor is correctly ballasted, operated at reduced speed and operated with the front-wheel drive engaged (if equipped).
- The braking characteristics are different between 2 and 4-wheel drive. Be aware of the difference and use carefully.
- When driving down a slope, ensure that the 4-wheel drive is engaged to increase traction.

1. Before operating the tractor on the road, be sure to interlock the right and left pedals as in the following illustration.
2. Use individual brakes to assist in making sharp turns at low speeds (field operation only). Disengage the brake pedal lock and depress only one brake pedal.
3. Be sure brake pedals have equal adjustment when being used locked together.

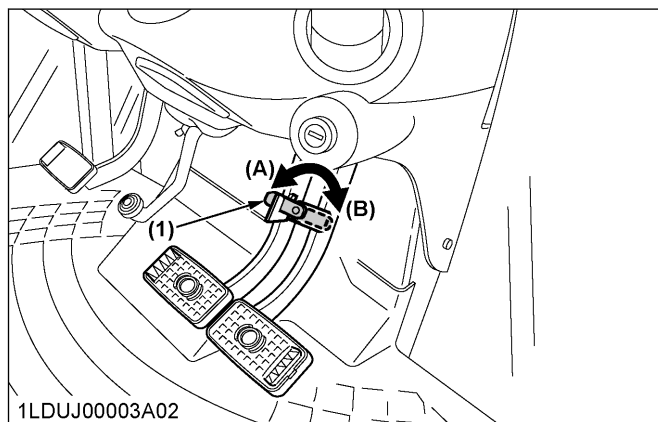

(1) Brake pedal lock (A) "LOCK" (B) "RELEASE"

8.1 4WD braking system (4WD model)

The 4WD model tractor is equipped with 4WD braking system. When both brake pedals are applied together, the front axle is engaged for 4-wheel braking regardless of the mode selected at the 4WD switch.

! WARNING

To avoid the possibility of personal injury, death or property damage from machine runaway during testing, service or repair with the rear wheels off the ground, make sure:

- Battery is disconnected and engine is not started.

If it is necessary to run the engine, make sure:

- Both front and rear wheels are off the ground and secured with stands before starting engine.

When you step on the brake pedal while driving in 2WD mode, the "4WD braking system" gets activated.

NOTE :

- The 4WD braking system is active even when the hydraulic system is damaged or the engine is stopped.

9. Parking brake lever

To release the parking brake, depress the brake pedals, push the release button and push the parking brake lever down to transport position.

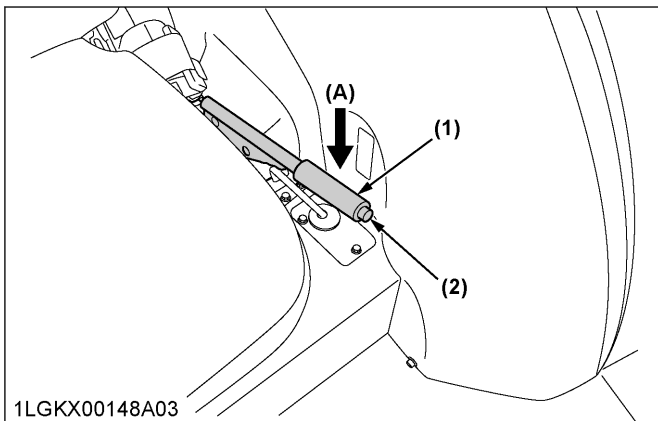

1LGKX00148A03
(1) Parking brake lever (A) "Push down to transport position"
(2) Release button

IMPORTANT :

- If the tractor is operated with the parking brake set, the parking brake will be damaged.
- If the tractor is traveling when the parking brake lever is applied, a warning buzzer will sound. If the buzzer sounds, immediately release the parking brake lever.

10. Gear-locked parking brake lever

To release the gear-locked parking brake, depress the brake pedals, push the release button and push the gear-locked parking brake lever to transport position.

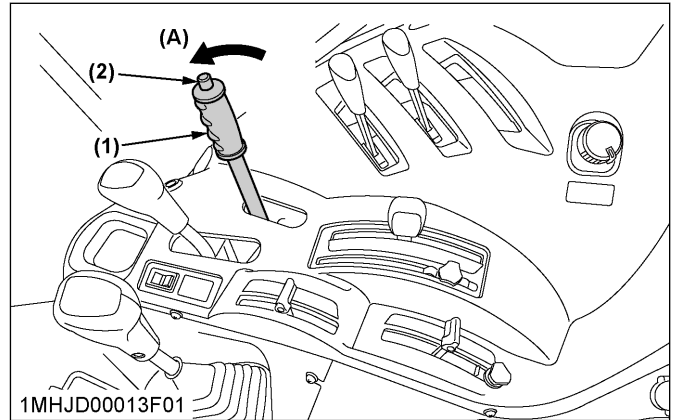

1MHJD00013F01
(1) Gear-locked parking brake lever (A) "Push to transport position"
(2) Release button

NOTE :

- In moving the gear-locked parking brake lever, you may feel it heavy sometimes, or light at other times. This is normal.
- The parking brake warning indicator on the Easy Checker™ will turn off when both parking brakes are released.
- If the shuttle shift lever is moved when the gear-locked parking brake is applied, a warning buzzer will sound.
- Be sure to apply both parking brakes after stopping the tractor.

11. Clutch pedal

! WARNING

To avoid personal injury or death:

- The sudden release of the clutch may cause the tractor to lunge in an unexpected manner.

The clutch is disengaged when the clutch pedal is fully pressed down.

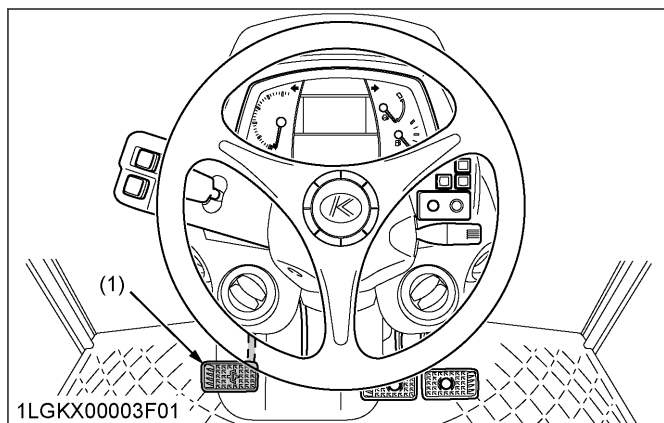

(1) Clutch pedal

IMPORTANT :

To help prevent premature clutch wear:

- The clutch pedal must be quickly disengaged and be slowly engaged.
- Avoid operating the tractor with your foot resting on the clutch pedal.
- Select proper gear and engine speed depending on the type of job.

12. Travel speed control

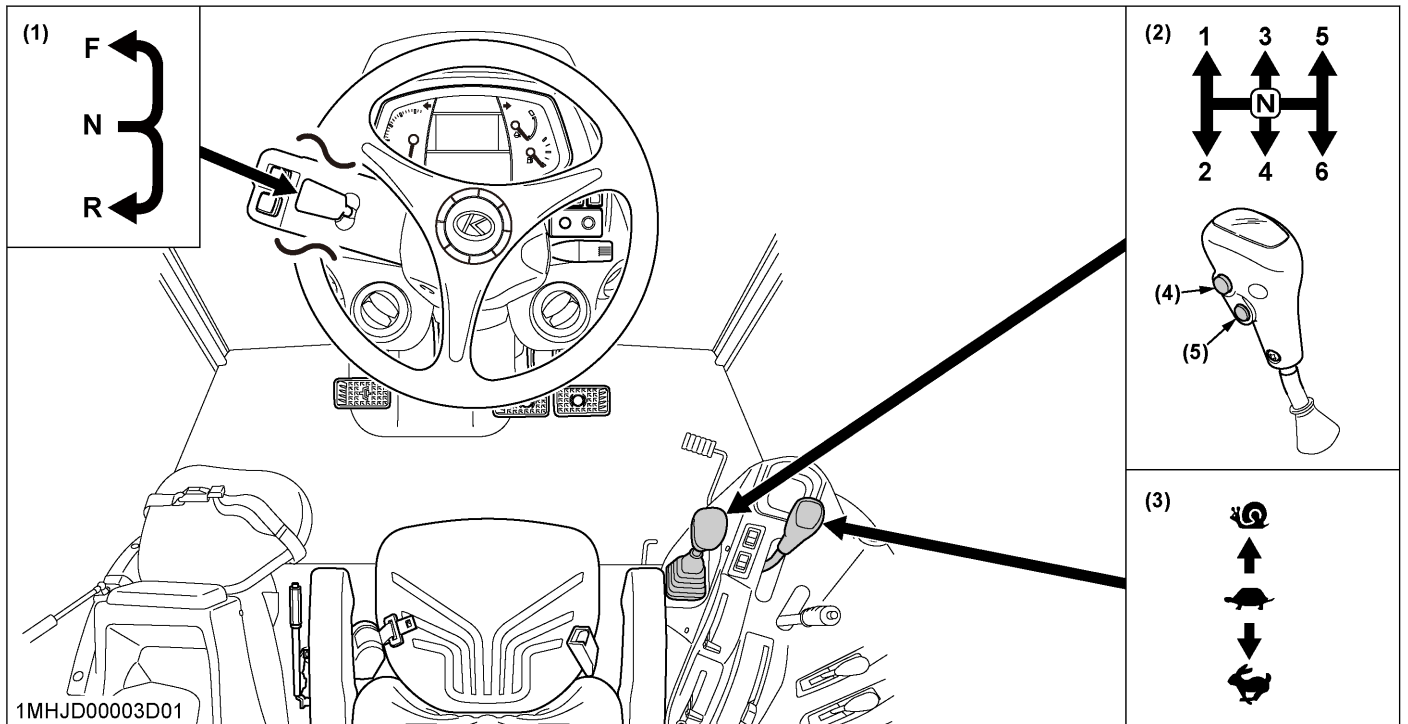

1MHJD00003D01

- | | | |
|---|------------------------|---------|
| (1) Shuttle shift lever | (F) "FORWARD" | "CREEP" |
| (2) Main gear shift lever | (N) "NEUTRAL POSITION" | "LOW" |
| (3) Range gear shift lever | (R) "REVERSE" | "HIGH" |
| (4) Clutch-off switch (if equipped) | | |
| (5) Dual speed shift switch (if equipped) | | |

By using the main gear shift lever, dual speed shift switch (if equipped), range gear shift lever and shuttle shift lever combination, the forward speeds and reverse speeds shown in the following table are obtained.

M5111 model with dual speed	36 forward speeds 36 reverse speeds
M5091/M5111 models without dual speed	18 forward speeds 18 reverse speeds

13. Travel speed limiter

The highest travel speed is reachable when the engine rpm is at around the middle level with the maximum travel speed range.

This provides for a fuel-efficient run while traveling along roads, pulling a trailer, and so on. Step on the foot throttle, and the engine rpm rises proportionally and the travel speed goes up accordingly.

But the engine speed is limited to 2080 rpm or so, and it does not increase even if the foot throttle is increased.

When the main gear shift lever is set to the [H-6] position, the *rev-limiter* indicator illuminates.

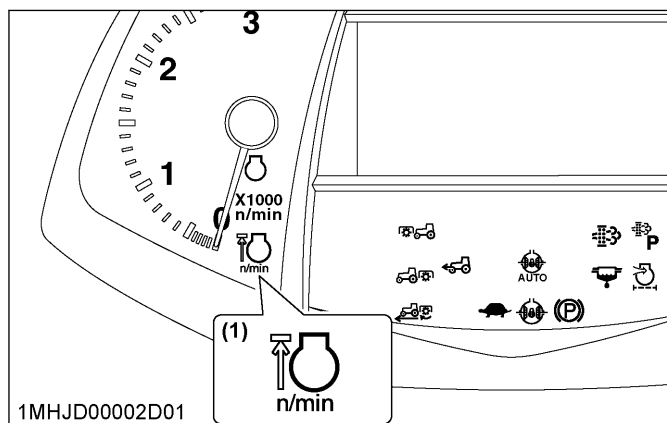

(1) Rev-limiter indicator

14. Main gear shift lever

The main gear shift is fully synchronized to shift without stopping.

IMPORTANT :

- The main gear shift may be shifted between speeds on-the-go, but the clutch must be depressed.

15. Range gear shift lever

The range gear shift can only be shifted when the tractor is completely stopped and the clutch is depressed.

IMPORTANT :

- To avoid transmission damage, depress the clutch pedal and stop the tractor before shifting between ranges.

15.1 Creep speed

! WARNING

To avoid personal injury or death:

- When you leave the tractor, be sure to apply both parking brakes and stop the engine.
- In applying the brakes:

– The torque of the wheel axle is extremely high while creep speed is being used. Be sure to step down on the clutch pedal completely before applying the brakes, or they will not work.

– When starting to operate the tractor, be sure to release both parking brakes. Misuse of the brakes may cause damage to the transmission and is therefore not acceptable to KUBOTA for coverage under the warranty.

IMPORTANT :

- Press the clutch pedal completely down and stop the tractor's motion before shifting the range gear shift lever.

Shift the range gear shift lever to to obtain low speeds.

This shifting requires clutch operation.

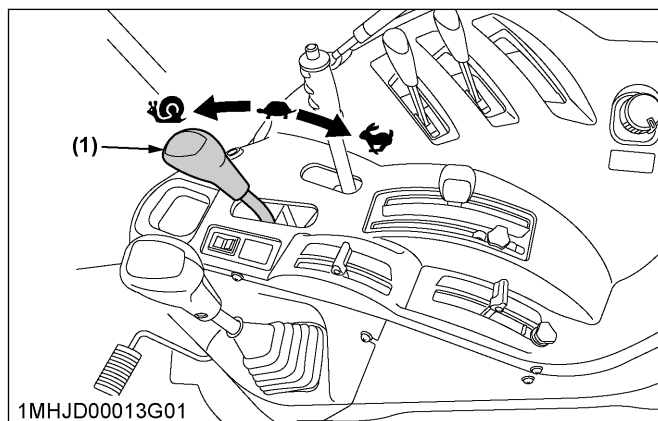

(1) Range gear shift lever (2) Creep "ON"

Creep speed should be used only when doing one of the following jobs:

- Deep rotary-tilling and harrowing
- Planting
- Turf application

Creep speed cannot be used for any of the following jobs:

- Pulling a trailer
- Front-loader operation
- Front-blade operation
- Earth-moving
- Entering and leaving a field
- Loading onto and unloading from a truck

16. Shuttle shift lever

! WARNING

To avoid personal injury or death:

- If the shuttle shift lever is moved in forward or reverse position while the gear-locked parking brake is applied, an alarm buzzer will sound.

If the buzzer sounds, return the shuttle shift lever to neutral position.

- If the gear-locked parking brake lever is released while the buzzer is sounding, the tractor will lunge unexpectedly.

Raise up and shift the shuttle shift lever forward to obtain forward speeds and shift back to obtain reverse speeds. This shifting does not require clutch operation.

IMPORTANT :

- The shuttle shift lever may be shifted while the tractor is moving slowly.

NOTE :

- While the shuttle shift lever is at the "NEUTRAL" position, the [N] character appears on the LCD monitor.

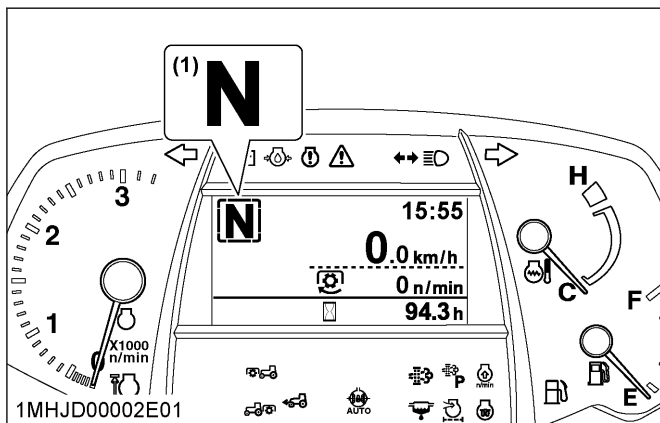

(1) "NEUTRAL"

17. Dual speed shift switch (if equipped)

The dual speed shift switch can be operated when the tractor is traveling without using the clutch. This switch affects tractor travel speed change by about 19%. "LO" speed and "HI" speed switch back and forth each time this switch is pushed.

Dual speed indicator

The indicator comes on when the dual speed switch is set to "LO".

The indicator goes off when the dual speed switch is set to "HI".

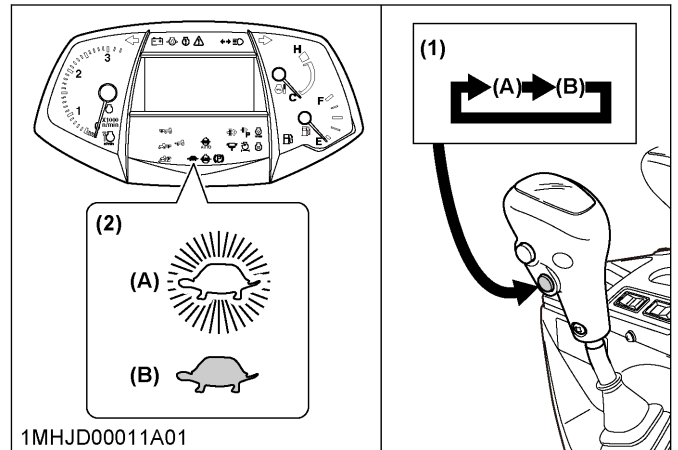

1MHJD00011A01

- (1) Dual speed shift switch
- (2) Dual speed indicator
- (A) "LO"
- (B) "HI"

18. Clutch-off switch (if equipped)

⚠ WARNING

To avoid personal injury or death:

- If you release the *clutch-off* switch when the travel speed is selected, the clutch becomes engaged and the tractor will begin to move.
- Always use the clutch pedal to start the tractor.

The *clutch-off* switch allows shifting gears without using the clutch pedal.

While pressing the *clutch-off* switch, the clutch is disengaged.

When the *clutch-off* switch is released, the clutch is engaged. Similarly to how the shuttle shift lever is shifted from [N] to [F] (or [R]), the clutch is engaged through a smooth wave-like motion.

NOTE :

- While pressing the *clutch-off* switch, the position display of the shuttle shift lever on the LCD monitor flashes.

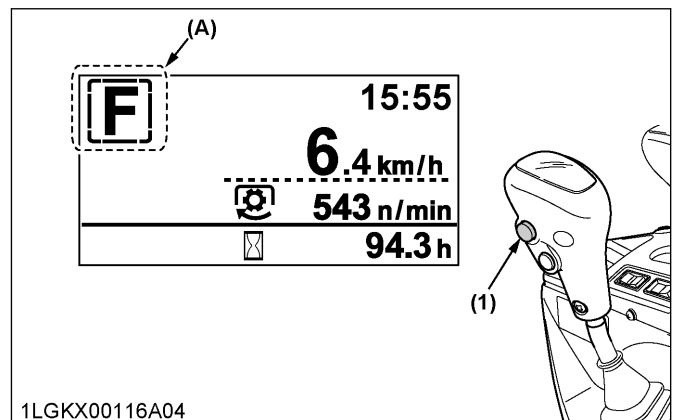

1LGKX00116A04

- (1) Clutch-off switch
- (A) "FLASH"

19. 4WD switch

WARNING

To avoid personal injury or death:

- Do not engage the front-wheel drive when traveling at road speed.
- When driving on icy, wet, or loose surfaces, make sure the tractor is correctly ballasted to avoid skidding and loss of steering control. Operate at reduced speed and engage front-wheel drive.
- 4WD model tractor is equipped with 4-wheel braking and appropriate care should be taken during hard braking.
- Do not brake suddenly.
An accident may occur as a result of a heavy towed load shifting forward or loss of control.
- The braking characteristics are different between 2 and 4-wheel drive tractor models. Be aware of the difference and use carefully.
- When driving down a slope, ensure that the 4-wheel drive is engaged to increase traction (if equipped).

Press the bottom half of this switch;

- The front-wheel drive (4WD) is engaged.
- The switch with indicator and 4WD indicator come on when the system is in 4WD mode.

Press the top half of this switch;

- The drive system returns to 2WD mode.
- The all indicators goes off when the system is in 2WD mode.

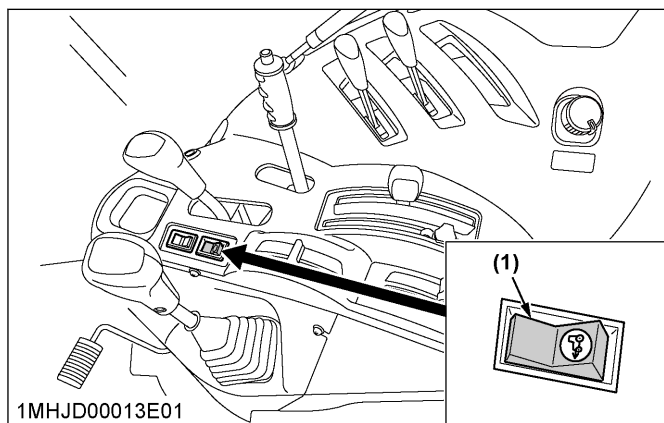

1MHJD00013E01

(1) 4WD switch with indicator

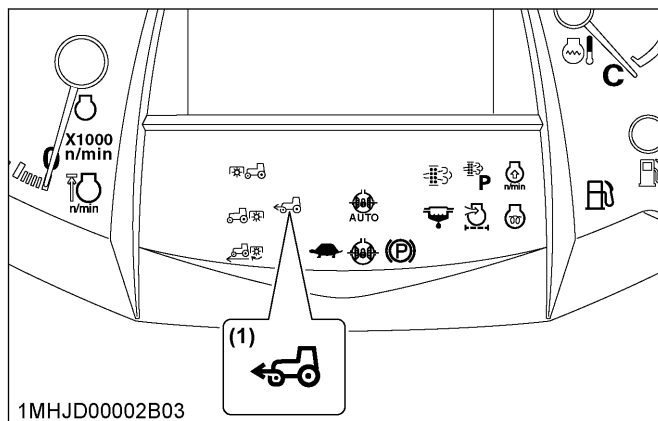

1MHJD00002B03

(1) 4WD indicator

19.1 Front-wheel drive (4WD) usage

Front-wheel drive is effective for the following jobs:

- When greater pulling force is needed, such as working in a wet field, when pulling a trailer, or when working with a front-end loader.
- When working in sandy soil.
- When working on a hard soil where a rotary tiller might push the tractor forward.

IMPORTANT :

- Tires will wear quickly if the front-wheel drive is engaged on paved roads.

20. Hand throttle lever

Pulling the throttle lever back decreases engine speed, and pushing it forward increases engine speed.

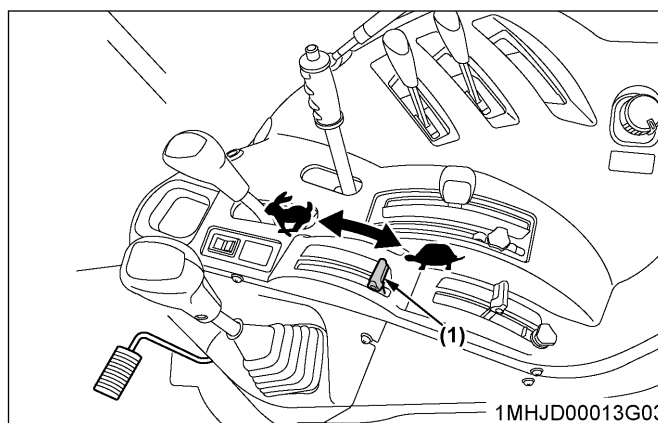

1MHJD00013G03

(1) Hand throttle lever

 "INCREASE"
 "DECREASE"

21. Foot throttle

Use the foot throttle when traveling on the road. Press down on it for higher speed. The foot throttle is interlocked with the hand throttle lever; when using the foot throttle, keep the hand throttle lever in low idling position.

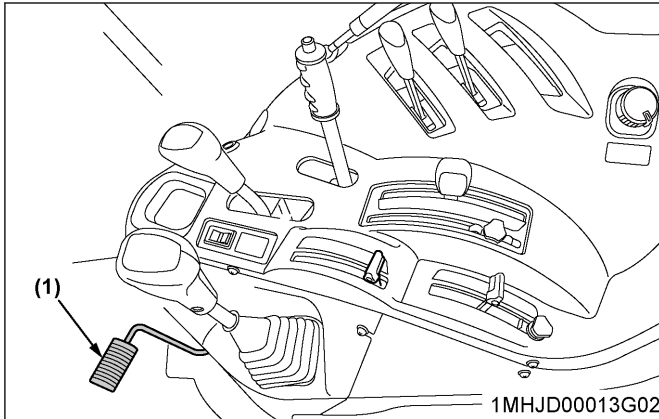

(1) Foot throttle

STOPPING THE TRACTOR

1. Slow down the engine.
2. Step on the clutch and brake pedal.
3. Wait for the tractor to stop.
4. Disengage the PTO.
5. Lower the implement to the ground.
6. Shift the transmission to neutral.
7. Release the clutch pedal.
8. Set both parking brakes.

CHECK DURING DRIVING

IMPORTANT :

Immediately stop the engine if:

- The engine suddenly slows down or accelerates.
- Unusual noises are suddenly heard.
- Exhaust fumes suddenly become very dark.

While driving, check the following items to see that all the parts are functioning normally:

- Engine over-speed limiting indicator on page 61
- Easy Checker™ on page 61
- Fuel gauge on page 62
- Coolant temperature gauge on page 63
- Tachometer on page 63

1. Engine over-speed limiting indicator

The engine over-speed limiting indicator informs the operator of engine over-speed by indicator and warning buzzer.

If the warning sounds, immediately lower engine rpm with brakes and such. When the engine rpm decreases, the warning will stop.

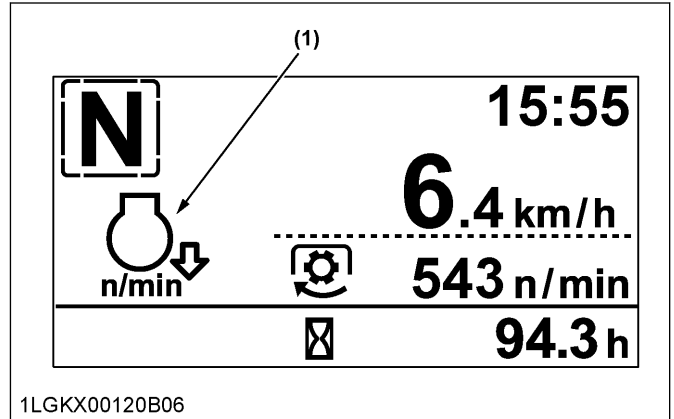

1LGKX00120B06

(1) Engine over-speed limiting indicator

NOTE :

- Normal operation will not lead to over-speed, but, for instance, if suddenly shifting down when running with a trailer at full speed, the tractor will be pushed by the trailer and may go into over-speed.

2. Easy Checker™

If the indicators on the Easy Checker™ come on during operation, immediately stop the engine and find the cause as follows.

Never operate the tractor while an Easy Checker™ indicator is on.

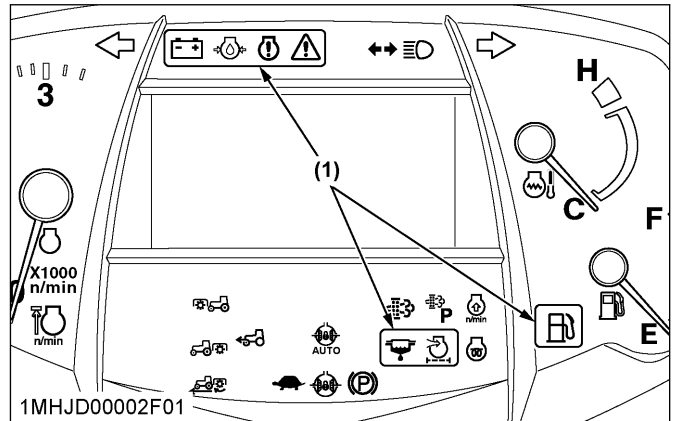

1MHJD00002F01

(1) Easy Checker™

⚠ Engine warning

This indicator serves the following 2 functions. If the indicator lights up, pinpoint the cause and take proper measures.

1. Error with the engine control system
If during operation the water temperature gauge reads an acceptable level but the indicator on the Easy Checker™ comes on, stop the engine and then restart it. If the error happens again, consult your local KUBOTA Dealer.

IMPORTANT :

- If the warning indicator lights up, the following phenomena may appear depending on the engine's trouble spot.
 - The engine stops unexpectedly.
 - The engine fails to start or gets interrupted just after starting.
 - The engine output is not enough.
 - The engine output is enough, but the warning indicator stays on.

If the engine output is not enough, immediately interrupt the operation and move the tractor to a safe place and stop the engine.

2. Engine overheat

If the water temperature gauge reads an unusual level and the indicator on the Easy Checker™ comes on, the engine may have overheated. Check the tractor by reading the troubleshooting section of this manual.

(See TROUBLESHOOTING on page 141.)

 **Engine oil pressure**

If the oil pressure in the engine drops below the prescribed level, the indicator on the Easy Checker™ will come on.

If this should happen during operation, and it does not go off when the engine is accelerated to more than 1000 rpm, check the engine oil level.

(See Checking engine oil level on page 112.)

 **Fuel level**

If the fuel in the tank drops below the prescribed level (less than 16 L), the indicator on the Easy Checker™ will come on.

If this should happen during operation, refuel as soon as possible.

(See Checking and refueling on page 111.)

IMPORTANT :

- When the fuel indicator lights up, refuel the tank as soon as possible. If the tractor runs out of fuel and stalls, the engine and its components may be damaged.

 **Water separator**

If water or impurities collect in the water separator, the indicator on the Easy Checker™ will light up.

If this should happen during operation, drain the water from the water separator as soon as possible.

(See Checking water separator on page 112.)

 **Air cleaner**

If the air cleaner is clogged, the indicator on the Easy Checker™ will come on.

If this should happen during operation, clean the air cleaner element.

(See Cleaning air cleaner primary element on page 119.)

 **Electrical charge**

If the alternator is not charging the battery, the indicator on the Easy Checker™ will come on. If this should happen during operation, check the electrical charging system or consult your local KUBOTA Dealer.

 **Master system warning**

If trouble should occur at the engine, transmission or other control parts, the indicator flashes as a warning.

If the trouble is not corrected by restarting the tractor, consult your local KUBOTA Dealer.

NOTE :

- For checking and servicing of your tractor, consult your local KUBOTA Dealer for instructions.

3. Fuel gauge

When the key switch is on, the fuel gauge indicates the fuel level.

Be careful not to empty the fuel tank. Otherwise, air may enter the fuel system.

Should this happen, the system should be bled.

(See Bleeding fuel system on page 134.)

If the engine runs out of fuel and stalls, the master system warning indicator lights up. When the indicator appears, turn the key switch to "OFF" and then to "ON" again in order to turn off the indicator.

If the indicator does not turn off by restarting the tractor, consult your local KUBOTA Dealer.

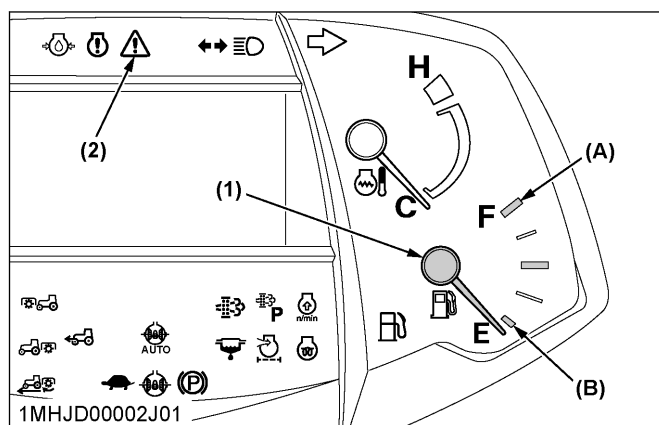

- (1) Fuel gauge
- (2) Master system warning indicator
- (A) "FULL"
- (B) "EMPTY"

4. Coolant temperature gauge

WARNING

To avoid personal injury or death:

- Do not remove the radiator cap until coolant temperature is well below its boiling point. Then, loosen the cap slightly to the first stop to relieve any pressure before removing the cap completely.

- With the key switch at "ON", this gauge indicates the temperature of the coolant. [C] is for cold and [H] is for hot.
- If the indicator reaches the red zone position, the engine coolant is overheated. Check the tractor by reading the troubleshooting section of this manual. (See TROUBLESHOOTING on page 141.)

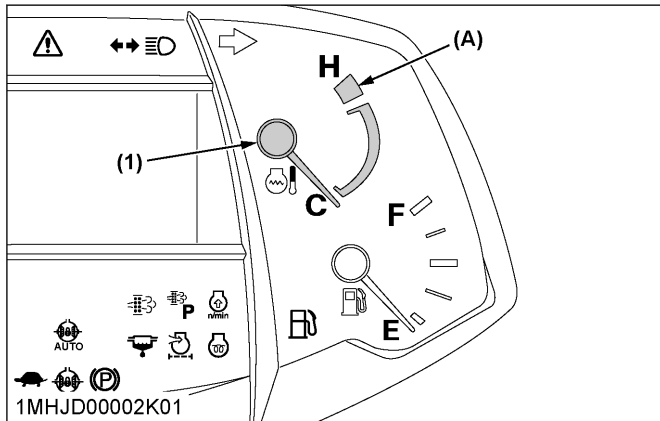

(1) Coolant temperature gauge (A) "RED ZONE"

5. Tachometer

The tachometer indicates the engine speed on the dial.

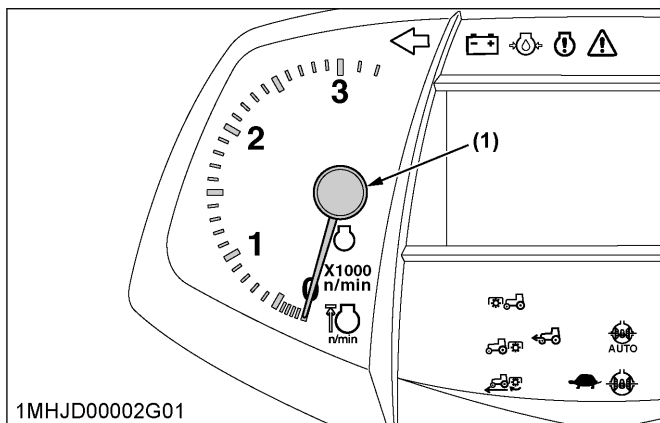

(1) Engine revolution

LCD MONITOR

This display provides the operator with a variety of information necessary to operate the tractor. Further,

part of the display can be modified by the operator as required.

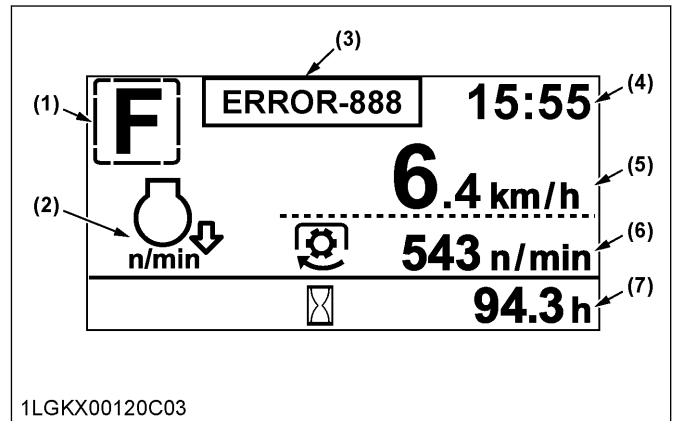

1LGKX00120C03

No.	Description	Reference page
(1)	F	Forward operation is selected with the shuttle lever. ---
	R	Reverse operation is selected with the shuttle lever. ---
	N	The shuttle lever is at neutral position. ---
	P	The gear-locked parking brake lever is at parking position. ---
	P	Travel when the gear-locked parking brake lever is engaged. ---
	Blinking	Clutch-off switch is pushed (if equipped). Clutch is disengaged. ---
No display	Shuttle lever system trouble. ---	
(2)	Engine over-speed limiting indicator 61	
(3)	Trouble display A trouble-spot-pinpointing error code and the related control unit are displayed. 142	
(4)	Clock 64	
(5)	Travel speed 64	
(6)	PTO speed 64	
(7)	Performance monitor Various information can be selected by the operator. 68	

NOTE :

- Errors may occur in the fuel consumption display depending on the conditions of use. Use the displayed data only as an approximate guide. In particular, do not use the total fuel

consumption display mode in place of the fuel gauge.

- The travel speed displayed when the wheels slip under traction is different from the actual one.
- In cold weather, the LCD monitor response will normally be slower and the visibility be less than in warmer weather.

1. Various setting mode

While pressing the mode selector switch, turn the key switch to "ON" position.

The various setting mode screen appears on the LCD monitor. The various setting mode can set 5 items.

Turn the key switch to "OFF" position to finish setting.

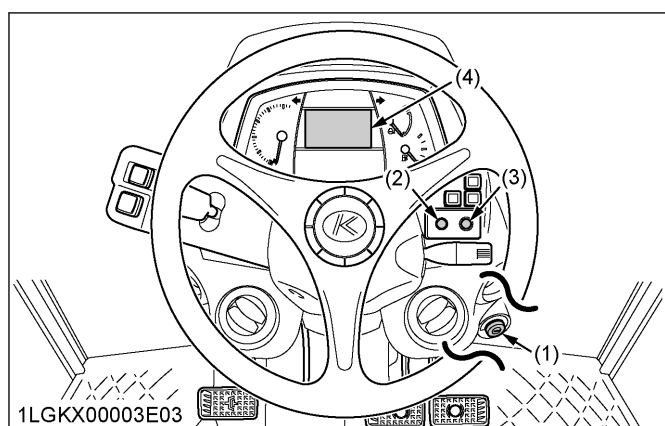

- 1LGKX00003E03
- (1) Key switch
 - (2) Mode selector switch
 - (3) Select switch
 - (4) LCD monitor

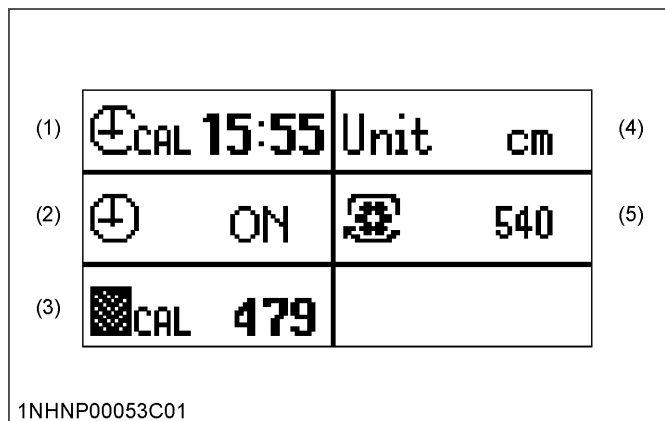

- 1NHNP00053C01
- (1) Clock setting
 - (2) Clock ON/OFF setting
 - (3) Tire circumference setting
 - (4) Unit setting
 - (5) PTO speed display setting

1.1 Clock setting

1. Press the mode selector switch to choose "Clock setting".

Then press the select switch, and the clock setting screen appears.

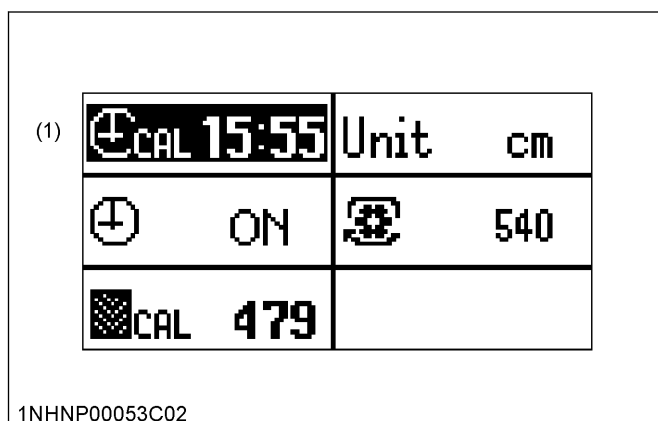

1NHNP00053C02

(1) Clock setting

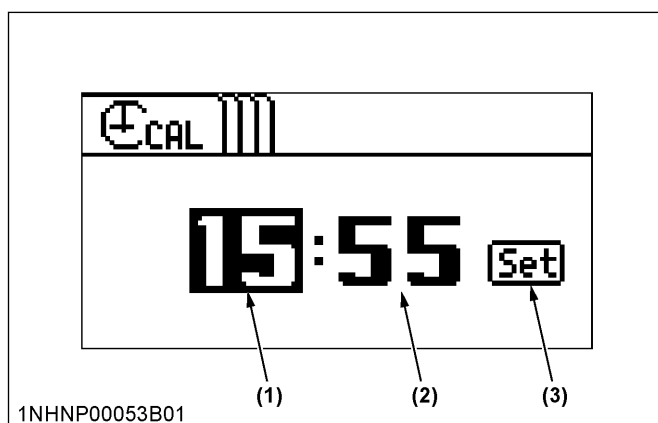

1NHNP00053B01

- (1) Hour
- (2) Minute
- (3) Set switch

2. Setting the "Hour" of the clock:

- a. Press the mode selector switch to choose the "Hour" (highlighted).
- b. To put the clock forward, press the select switch.

3. Setting the "Minute" of the clock:

- a. Press the mode selector switch to choose the "Minute" (highlighted).
- b. Carry out the "Minute" setting in the same way as the "Hour" setting.

4. Press the mode selector switch.

5. To complete the setting, select "Set" with the select switch.

The various setting mode screen appears again.

1.2 Setting the clock display ON/OFF

1. Press the mode selector switch to choose "Clock ON/OFF setting".
Then press the select switch, and the clock ON/OFF setting screen appears.

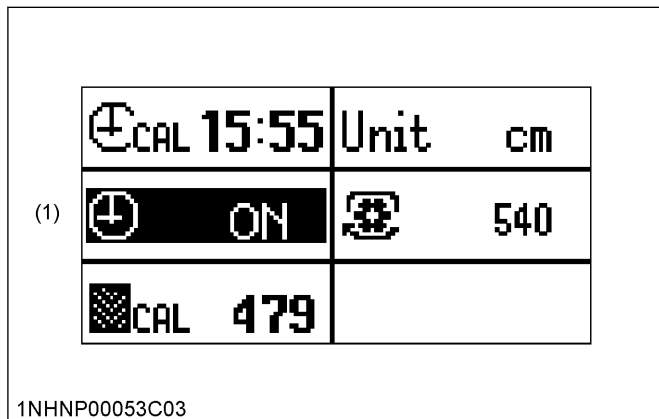

(1) Clock ON/OFF setting

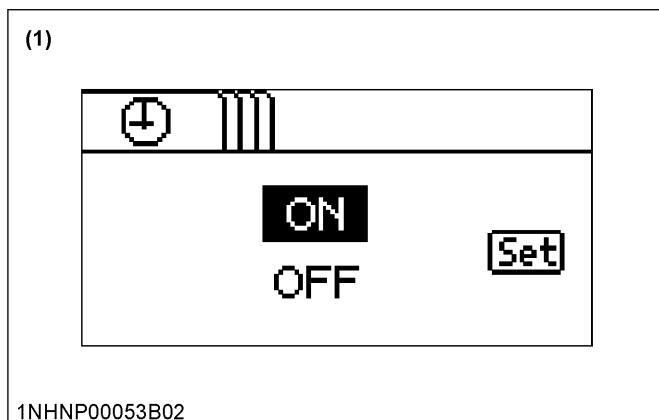

(1) Clock ON/OFF setting screen

2. Press the select switch and select "ON" or "OFF".
3. Press the mode selector switch.
4. To complete the setting, select "Set" with the select switch.
The various setting mode screen appears again.

1.3 Setting the tire circumference

When optional different-diameter tires are fitted on the machine, the travel speed display mode must be changed. Otherwise, the travel speed will not be correctly displayed. Such mode switching is also needed when the original tires are back on the machine.

1. Press the mode selector switch to choose "Tire circumference".
Then press the select switch, and the tire circumference setting screen appears.

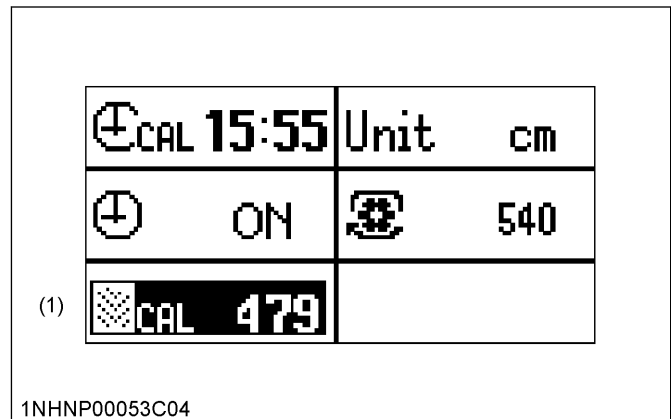

(1) Tire circumference

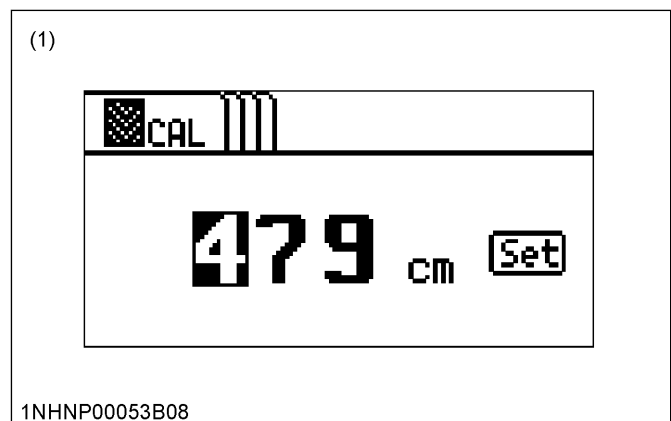

(1) Tire circumference screen

2. According to the following table, enter the tire circumference value.
 - a. Press the mode selector switch to select a digit.
 - b. To put the number forward, press the select switch.
The numeral changes from 0 to 9 at each push of the switch.

Tire circumference table (reference)

Rear tire size	Entry (cm)
420/85R30	455
460/85R30	467
340/85R38	469
420/85R34	474
480/70R30	442
480/70R34	479

3. Press the mode selector switch.
4. To complete the setting, select "Set" with the select switch.
The various setting mode screen appears again.

1.4 Setting the unit

1. Press the mode selector switch to choose "Unit setting". Then press the select switch, and the unit setting screen appears.

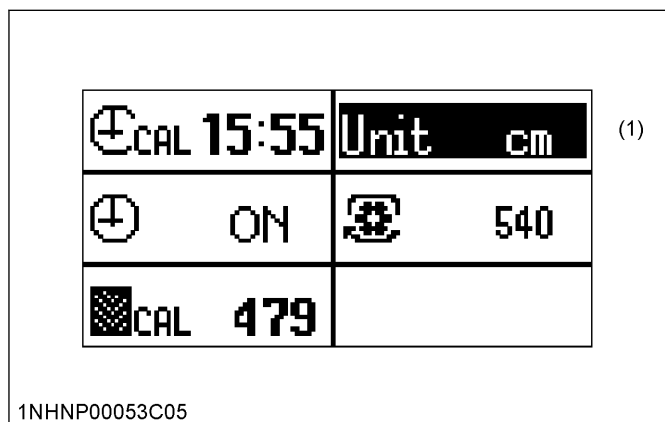

(1) Unit setting

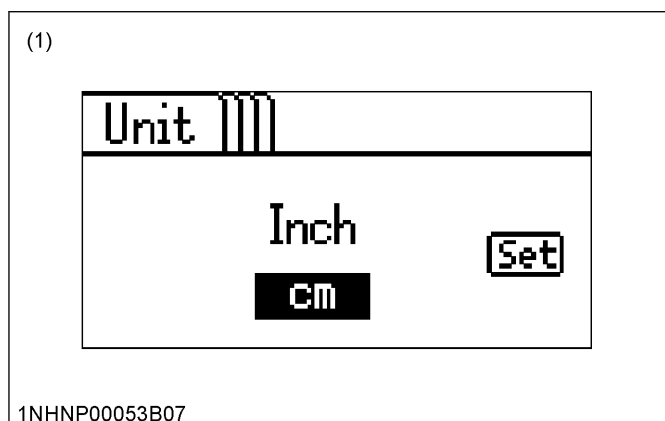

(1) Unit setting screen

2. Press the select switch to select "Inch" or "cm".
3. Press the mode selector switch.
4. To complete the setting, select "Set" with the select switch.
The various setting mode screen appears again.

1.5 Setting the PTO speed display

540/540E rpm model

The PTO speed display mode has been factory-set at "540/540E". Do not attempt to change the setting. Otherwise the correct PTO speed will not be displayed on the LCD monitor.

540/1000 rpm model

The PTO speed display mode has been factory-set at "540/1000". Do not attempt to change the setting. Otherwise the correct PTO speed will not be displayed on the LCD monitor.

Interchangeable PTO 540/1000 rpm model

Whenever the PTO speed is changed to the other speed, it is necessary to switch the PTO speed display

mode. Otherwise the PTO speed will not be correctly displayed on the LCD monitor. When the PTO speed is changed from 540 rpm to 1000 rpm or from 1000 rpm to 540 rpm, it is necessary to switch the PTO speed display mode.

NOTE :

- The current setting can be checked in the following procedure.

1. Press the mode selector switch to choose "PTO speed display setting". Then press the "Select" switch, and the PTO speed display setting screen appears.

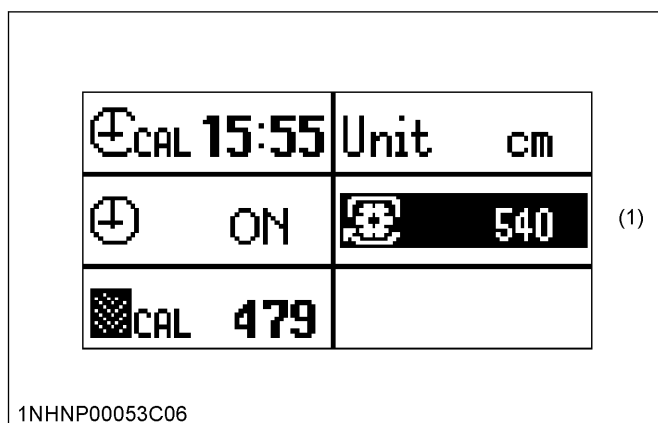

(1) PTO speed display setting

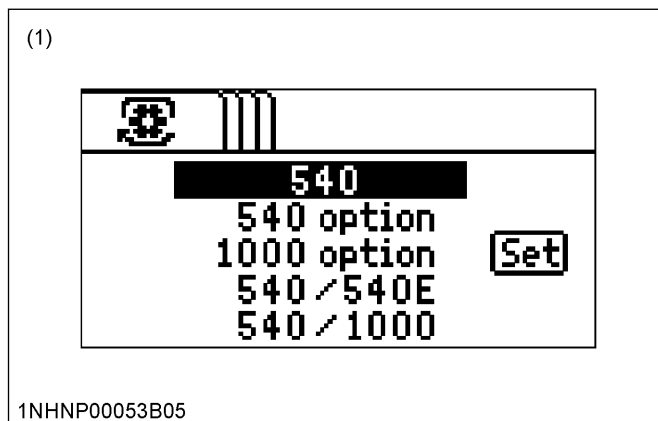

(1) PTO speed display setting screen

2. According to the following table, press the "Select" switch and select the PTO speed.

Model	Select the PTO speed (rpm)
Standard	Not select
With interchangeable PTO shaft	540 option
	1000 option
With PTO gear shift lever	540/540E
	540/1000

3. Press the mode selector switch.

4. To complete the setting, select **[Set]** with the “*Select*” switch.
The various setting mode screen appears again.

2. Performance monitor

Display change

Use the mode selector switch and select switch to choose one of the items shown in the following table to be displayed on screen.

Priority display

- When the *RPM dual memory* setting is “ON”, the engine rpm A or B is displayed on the screen. When selecting any other information such as “*Hour meter*” or “*PM buildup*”, the item will be displayed for approximately 5 seconds before resuming the engine rpm A or B display.
- Turn “OFF” the *RPM dual memory* setting to display any other information continuously.
(See *RPM dual memory* setting on page 69.)

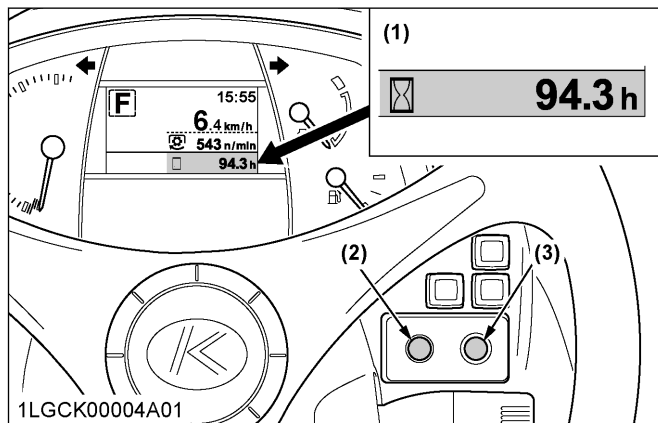

- (1) Performance monitor
- (2) Mode selector switch
- (3) Select switch

List of types of information displayed on the performance monitor

Selected screen (mode)	Display	Remarks	Reference page	
1/4		Elapsed time (hour meter)	<ul style="list-style-type: none"> The hour meter indicates in 6 digits the hours for which the tractor has been used; the last digit indicates 1/10 of an hour. 	---
		Trip meter	<ul style="list-style-type: none"> The total operating hours, counted from the previous re-setting, is displayed. 	---
2/4		Instantaneous fuel consumption	<ul style="list-style-type: none"> The “<i>Instantaneous fuel consumption</i>” is measured per hour. 	---
		Average fuel consumption	<ul style="list-style-type: none"> The “<i>Average fuel consumption</i>” is measured per hour from the previous resetting. 	---
		Total fuel consumption	<ul style="list-style-type: none"> The total fuel consumption, measured from the previous resetting, is displayed. 	---
3/4		PM buildup (percentage)	<ul style="list-style-type: none"> The PM buildup inside the DPF muffler is displayed. Regeneration is needed when the 100% level has been reached. The more the bar is extended to the right, the more PM has built up. 	---
		PM buildup (graph)		
4/4		Memory A rpm	<ul style="list-style-type: none"> <i>Engine RPM dual memory</i> A rpm is displayed. 	69
		Memory B rpm	<ul style="list-style-type: none"> <i>Engine RPM dual memory</i> B rpm is displayed. 	69

NOTE :

- Hold down the mode selector switch for 2 seconds or longer to reset the “*Trip meter*”, “*Average fuel consumption*” and “*Total fuel consumption*” displays to “0.0”.

ELECTRONIC ENGINE CONTROL

The electronically controlled engine which is installed in this tractor performs the following 2 types of control.

1. *RPM dual memory setting*
2. *Constant RPM Management control*

1. RPM dual memory setting

Two different engine speeds can each be set with a single touch by pressing the *RPM dual memory* switch to the (A) or (B) side. This can be used to eliminate troublesome acceleration operations.

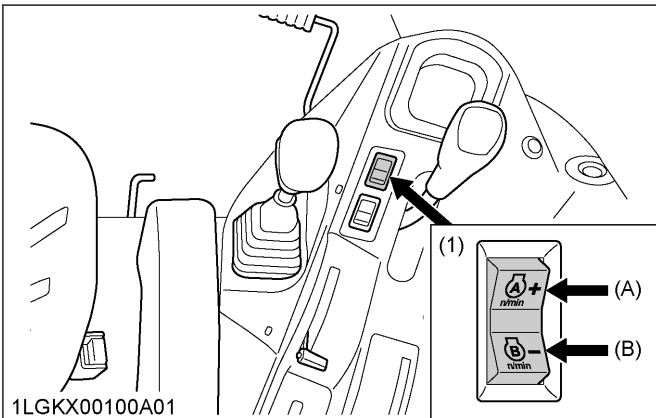

(1) *RPM dual memory switch* (A) *Switch A*
(B) *Switch B*

Example of use

Consider an example in which an engine speed of 2000 rpm is set for the switch (A) side and a speed of 1000 rpm is set for the switch (B) side.

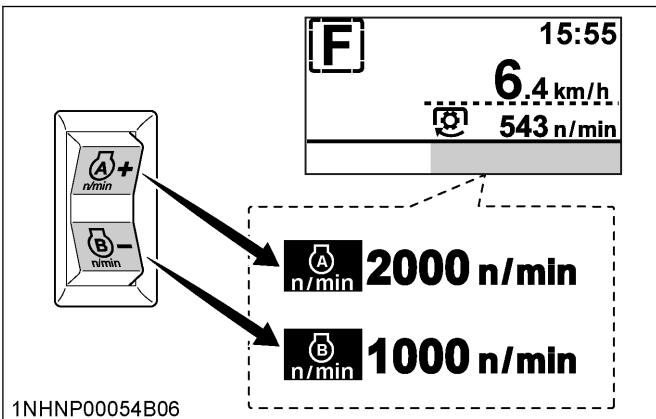

Work ↓	 1AGBDABAP033B	During work, simply press the switch to the (A) side to automatically set an engine speed of 2000 rpm.
Turning ↓	 1AGBDABAP033C	When turning, press the switch to the (B) side to lower the speed to 1000 rpm, allowing turning at low speed.
Work	 1AGBDABAP033B	After turning, press the switch again to the (A) side to resume a speed of 2000 rpm.

- Keep the hand throttle lever above the minimum speed. At the minimum speed, a memory setup cannot be performed.
- You can also depress the foot throttle to increase the engine speed above the set speed.

Setting the speeds or changing the speed settings

Setting *RPM dual memory* switch (A).

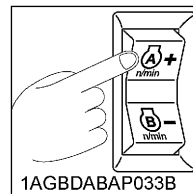

1. Turn the key switch to "ON".
The speed setting can be made both when the engine is running and when it is stopped.

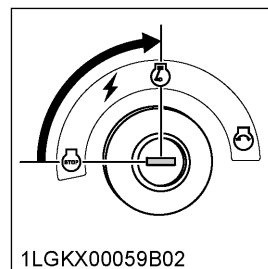

2. Set the hand throttle lever slightly toward the higher-speed side.

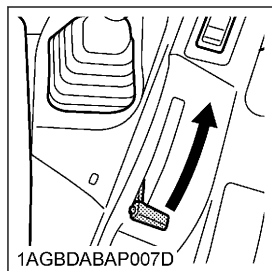

3. Press the switch (A) side and then release the switch.

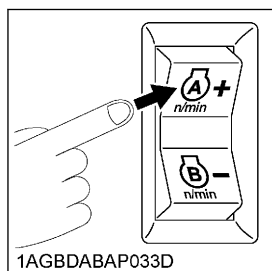

4. Press again and hold down the switch (A) side (2.5 seconds) until the buzzer sounds and then release the switch.

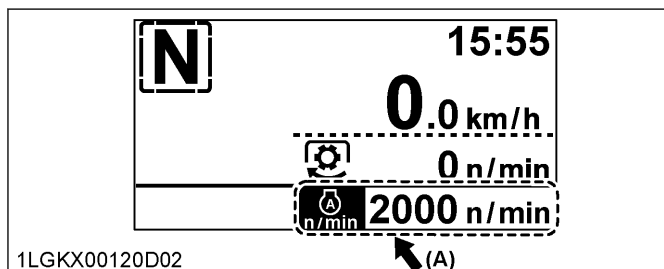
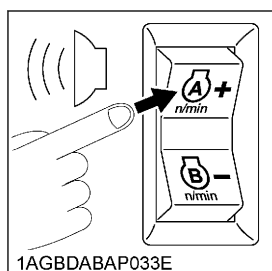

5. Press the switch to the (A) or (B) side and set the speed.
Pressing and holding down the switch will cause the speed to change continuously. Pressing and releasing the switch changes the speed by 10 rpm each time. Set the desired engine speed while watching the speed display.

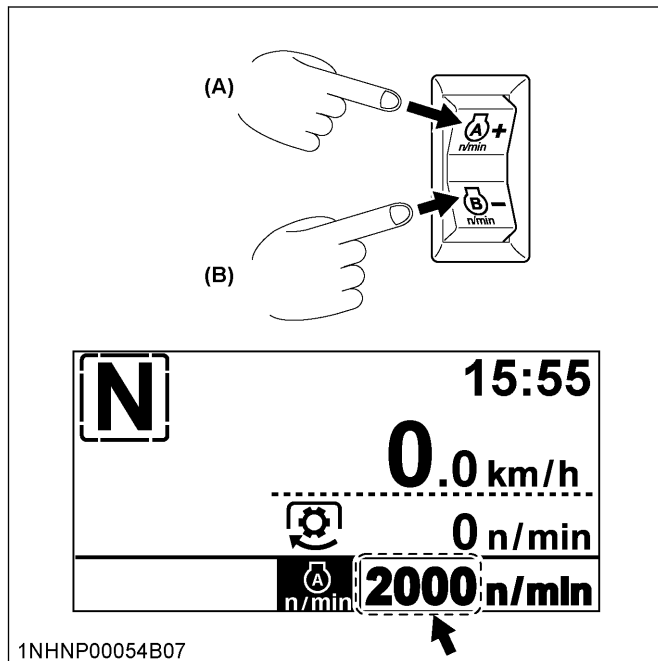

(A) Increase speed
(B) Decrease speed

6. If the switch is released and not operated for 4 seconds, a continuous buzzer sounds and the setting is completed.
7. Follow the same procedure as for the (A) side to set the speed for the switch (B) side.

NOTE :

- The set speeds will be stored even after the engine is stopped.

Canceling the setting

Any of the actions below will cancel the *RPM dual memory* settings.

1. For the switch (A) side, when the memory speed is engaged, press the switch (A) again to cancel. For the switch (B) side, when the memory speed is engaged, press the switch (B) again to cancel.
2. When the memory speed is canceled, the speed will return to the speed that is determined by the hand throttle lever (foot throttle). When the switch is pressed, the LCD will display the engine speed that is in effect after memory speed is canceled.
3. Return the hand throttle lever to the lowest speed position.
4. Turn the key switch to "OFF".

2. Constant RPM Management control

Constant RPM Management can be turned "ON" or "OFF" by operating the switch. Pressing the switch turns the control "ON" and pressing the switch again turns it "OFF".

When Constant RPM Management is “ON”

Fluctuations in the engine speed due to load fluctuations are reduced and the travel speed and PTO speed are kept nearly constant, allowing stable work. When Constant RPM Management is “ON”, the switch’s indicator lights up.

When Constant RPM Management is “OFF”

As in a conventional engine, the engine speed increases or decreases according to changes in the load. The operator judges the size of the load from the engine speed and engine sound, and can adjust the travel speed or plowing depth to prevent overload on the tractor.

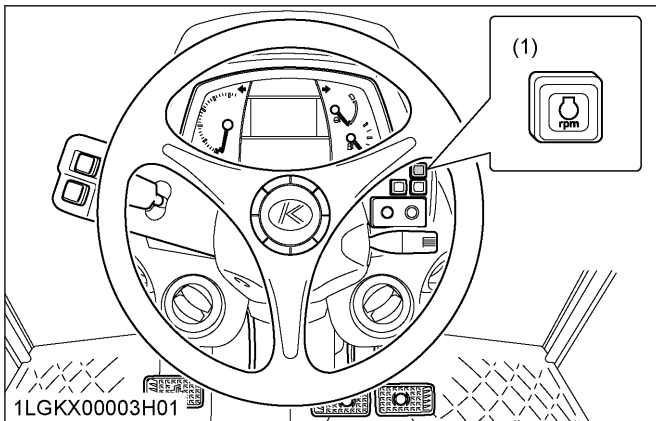

(1) Constant RPM Management switch with indicator

NOTE :

- In a mechanically-controlled engine, the engine speed changes according to increases and decreases in the load. For example, when working in a hilly area, the load increases and engine speed drops while ascending a slope, and conversely the engine speed increase and the load drops when descending. These changes in engine speed affect the travel speed and PTO-driven implements. In order to minimize these effects, the operator must make fine adjustments to the travel speed and hand throttle lever.
- When the Constant RPM Management switch in this tractor with its electronically controlled engine is turned “ON”, the engine speed will be kept nearly constant in response to a certain level of load fluctuations. This improves the accuracy of work without the need for troublesome manipulation of the travel speed and hand throttle lever.
- There is a limit to the range within which a constant speed can be maintained. If a load exceeding the engine performance is applied, the engine speed will drop.
- The purpose of Constant RPM Management is not to increase the engine power.

PARKING THE TRACTOR

When parking the tractor, set both the parking brake lever and the gear-locked parking brake lever.

! WARNING

To avoid personal injury or death:
Before dismounting tractor

- Always set both parking brakes and lower all implements to the ground. Leaving the transmission in gear with the engine stopped will not prevent the tractor from accidental rolling.
- Stop the engine and remove the key.

IMPORTANT :

- Do not leave your tractor in the rain. If it cannot be avoided, cover the muffler pipe to prevent water from entering.
1. Before getting off the tractor:
 - a. Disengage the PTO.
 - b. Lower all implements to the ground.
 - c. Place all control levers in their neutral positions.
 - d. Pull the parking brake lever up to the parking position.

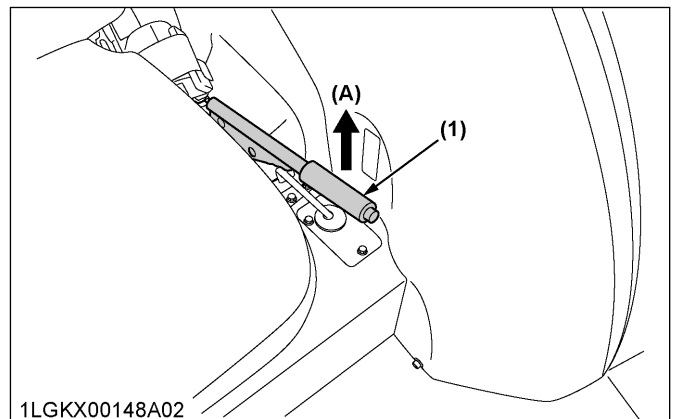

(1) Parking brake lever

(A) “Pull up to parking position”

- e. Pull the gear-locked parking brake lever to the parking position.

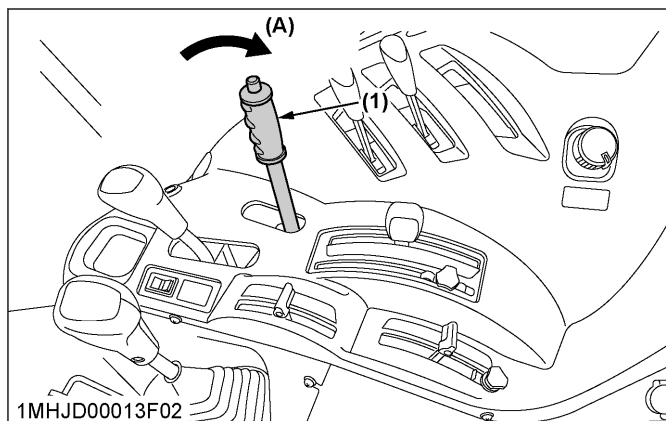

(1) Gear-locked parking brake lever (A) "Pull to parking position"

- f. Stop the engine.
 - g. Remove the key.
2. If it is necessary to park on an incline, be sure to chock the wheels to prevent accidental rolling of the tractor.

IMPORTANT :

For parking brake lever:

- If the tractor is operated with the parking brake set, the parking brake will be damaged.
- If the tractor is travelling when the parking brake lever is applied, a warning buzzer will sound.
If the buzzer sounds, immediately release the parking brake lever.

IMPORTANT :

For gear-locked parking brake lever:

- Bring the tractor to a complete stop before applying the gear-locked parking lever.

NOTE :

- The parking brake warning indicator on the Easy Checker™ will turn on when a parking brake is set.
- Be sure to apply both parking brakes after stopping the tractor.

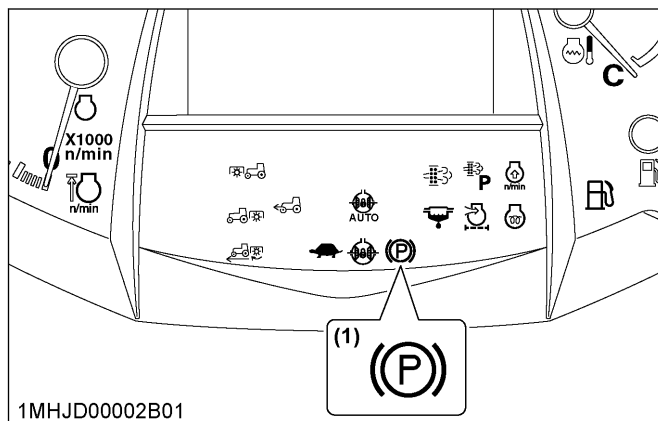

(1) Parking brake warning indicator

OPERATING TECHNIQUES

1. Differential lock

If one of the rear wheels starts slipping, engage the differential lock and both wheels will turn together, thus reducing wheel slip.

! WARNING

To avoid personal injury or death due to loss of steering control:

- Do not operate the tractor at high speed with differential lock engaged.
- Do not attempt to turn with the differential lock engaged.
- Be sure to release the differential lock before making a turn in field conditions.

Depending on the type of work, select either auto differential lock mode or manual differential lock mode.

Auto differential lock

In the auto differential lock mode, the rear wheels enter the differential lock state when the tractor's speed is between 0.5 km/h and 15 km/h.

Press the auto differential switch to engage or disengage the auto differential lock mode. When engaged, the auto differential lock indicator will turn on. To disengage the auto differential lock mode, perform one of the following operations:

1. Push the auto differential switch again.
2. Step on the differential lock pedal.
3. Step on the brake pedal.
4. Travel at under 0.5 km/h or over 15 km/h.

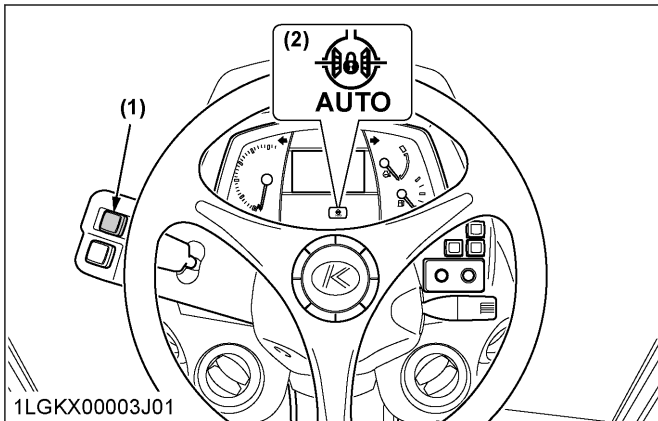

(1) Auto differential lock switch
(2) Auto differential lock indicator

Manual differential lock

The manual differential lock mode is engaged while the differential lock pedal is depressed.

Engage the manual differential lock mode according to the rear wheel slip.

The manual differential lock indicator lights up while the manual differential lock mode is engaged.

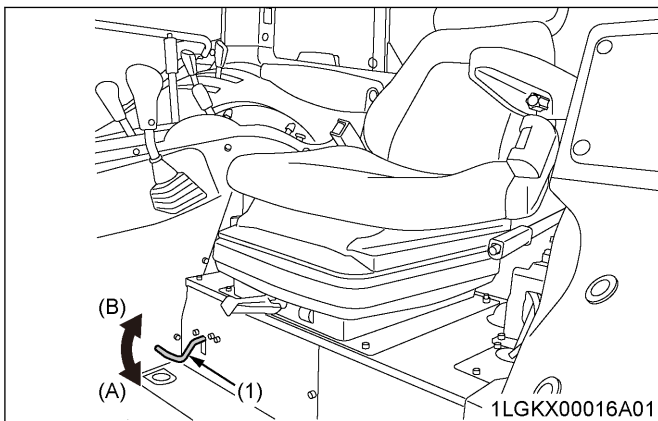

(1) Differential lock pedal
(A) Press to "ENGAGE"
(B) Release to "DISENGAGE"

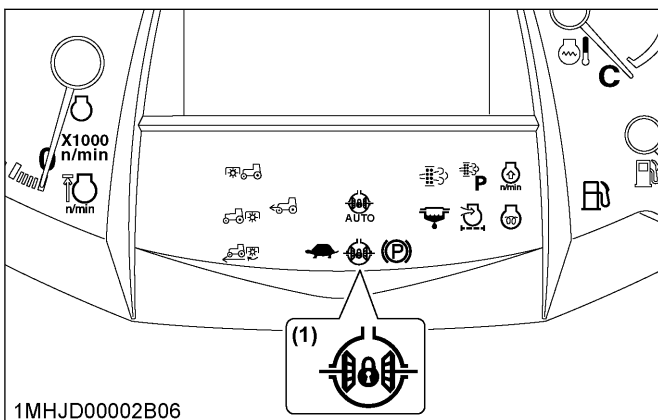

(1) Manual differential lock indicator

IMPORTANT :

- When using the differential lock, always slow the engine down.

- To prevent damage to the power train, do not engage the differential lock when one wheel is spinning and the other is completely stopped.
- If the differential lock cannot be released, step lightly on the brake pedals alternately.

2. Operating the tractor on a road

⚠ WARNING

To avoid personal injury or death:

- To help assure straight line stops when driving at transport speeds, lock the brake pedals together. Uneven braking at road speeds could cause the tractor to roll-over.
- When traveling on the road with a 3-point hitch mounted implement attached, be sure to have sufficient front weight on the tractor to maintain steering ability.
- When traveling on the road with or without a trailer, you must comply with local regulations at all time.

The maximum traveling speed with trailer is determined by each country, and regulated speeds may vary according to the size of the trailer and the type of trailer brake system.

Observe all local traffic and safety regulations. Use the registration plate.

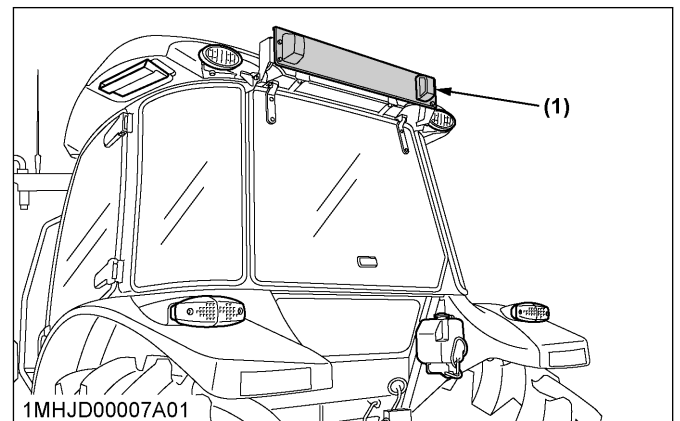

(1) Registration plate

3. Operating on slopes and rough terrain

⚠ WARNING

To avoid personal injury or death:

- Always back up when going up a steep slope. Driving forward could cause the tractor to tip over backward. Stay off hills and slopes too steep for safe operation.
- Avoid changing gears when climbing or descending a slope.

- If operating on a slope, never disengage the clutch or shift levers to neutral. Doing so could cause loss of control.
- Do not drive the tractor close to the edges of ditches or banks which may collapse under the weight of the tractor, especially when the ground is loose or wet.

1. Be sure wheel tread is adjusted to provide maximum stability.
(See WHEEL ADJUSTMENT on page 91.)
2. Slow down for slopes, rough ground, and sharp turns, especially when transporting heavy, rear-mounted equipment.
3. Before descending a slope, shift to a gear low enough to control the speed without using brakes.

4. Transporting the tractor safely

1. The tractor, if damaged, must be carried on a truck. Secure the tractor tightly with ropes.
2. Secure the tractor with chains or straps sized appropriately. Make sure all loading ramps are properly sized. Make sure all local tie-down requirements are met.
3. Follow the instructions below when towing the tractor. Otherwise, the tractor's powertrain may be damaged.
 - Set all the shift levers to "NEUTRAL" position.
 - If possible, start the engine and select 2WD; if creep speed is fitted ensure that it is disengaged.
 - Tow the tractor using its front hitch or drawbar.
 - Never tow faster than 10 km/h.

5. Directions for the use of power steering

- Power steering is activated only while the engine is running. Slow engine speeds make the steering a little heavier. While the engine is stopped, tractors with power steering function in the same manner as tractors without power steering.
- When the steering wheel is turned all the way to the stop, the relief valve is activated. Do not hold the steering wheel in this position for a long period of time.
- Avoid turning the steering wheel while the tractor is stopped, or tires may wear out sooner.
- The power steering mechanism makes the steering easier. Be careful when driving on the road at high speeds.

6. Trailer electrical outlet

A trailer electrical outlet is supplied for use with a trailer or implement.

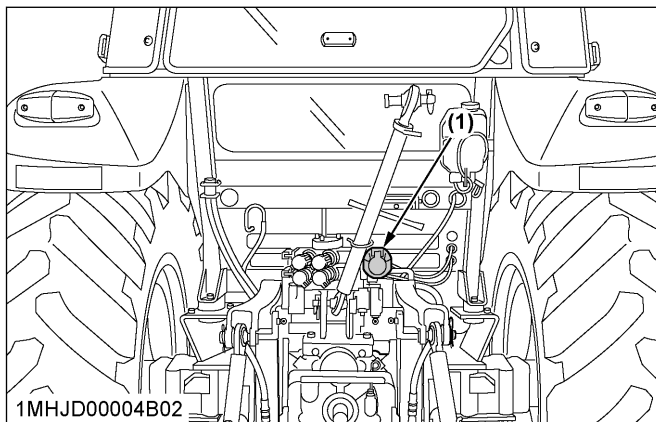

(1) Trailer electrical outlet

Function of each terminal in trailer electrical outlet

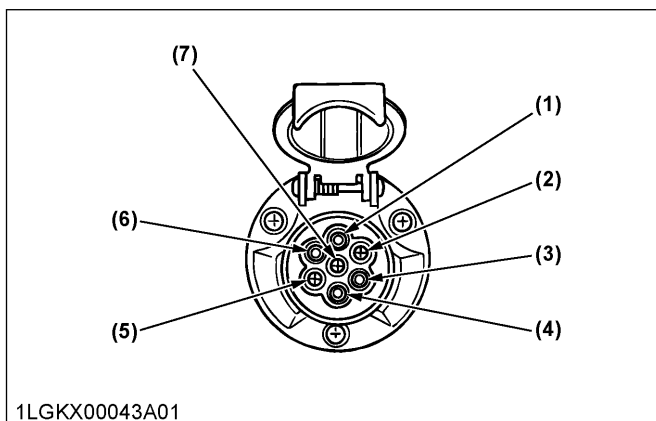

Terminal	Function
(1)	Turn signal light (LH)
(2)	---
(3)	Ground
(4)	Turn signal light (RH)
(5)	Tail light Side marker light Parking light
(6)	Brake stop light
(7)	Registration plate light

PTO

PTO OPERATION

WARNING

To avoid personal injury or death:

- Disengage the PTO, stop the engine, and allow all rotating components to come to a complete stop before connecting, disconnecting, adjusting, or cleaning any PTO driven equipment.

1. PTO clutch control switch

The PTO clutch control switch engages or disengages the PTO clutch which gives the PTO independent control.

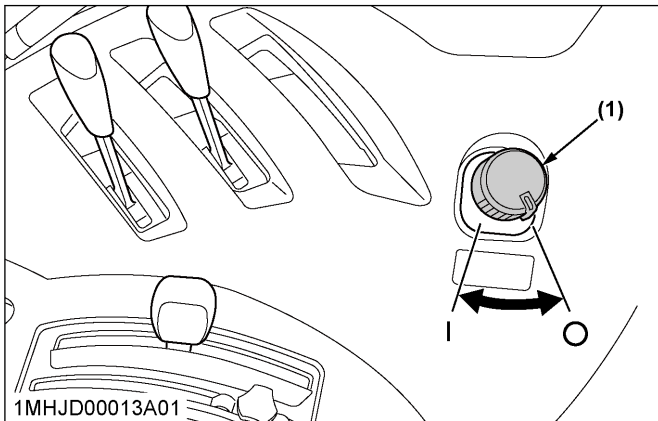

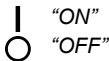
(1) PTO clutch control switch

Turn the switch to “ON” to engage the PTO clutch. Turn the switch to “OFF” to disengage the PTO clutch.

IMPORTANT :

- To avoid shock loads to the PTO, reduce engine speed when engaging the PTO, then open the throttle to the recommended speed.

NOTE :

- Tractor engine will not start if PTO clutch control switch is in the engaged “ON” position.

To turn “ON”

1. While pushing the switch, turn clockwise to the  position and release your hand (in the “ON” position, switch slightly rises itself).

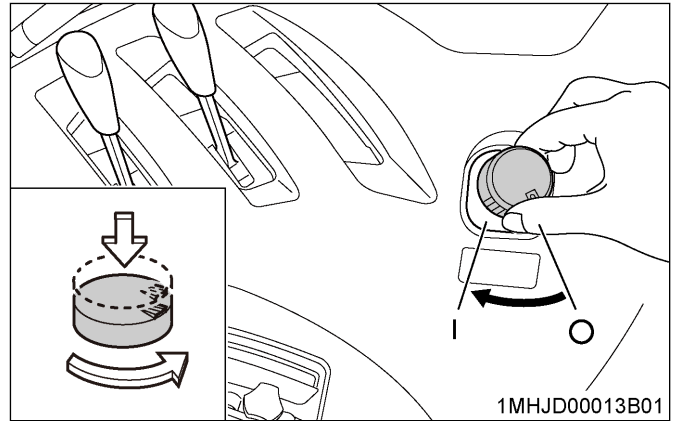

To turn “OFF”

1. Push the switch, and the switch will return to the “OFF” position.

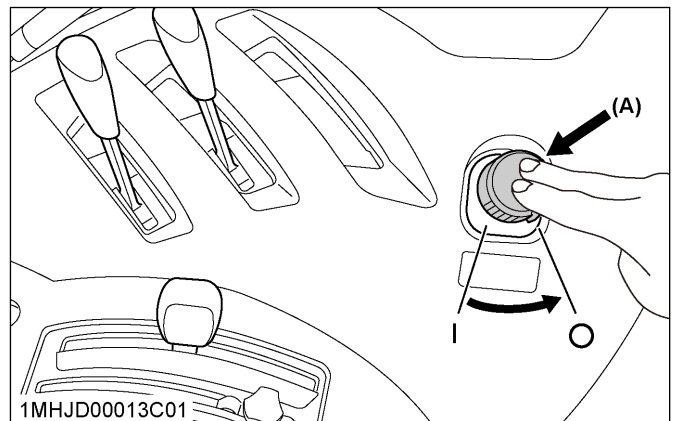

(A) “PUSH”

2. PTO clutch indicator

The PTO clutch indicator turns on while PTO clutch control switch is in “ON” (engage) position.

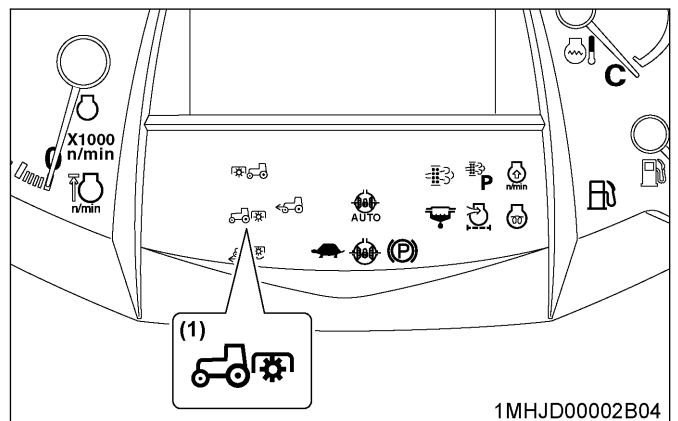

(1) PTO clutch indicator

3. PTO rpm display

The PTO rpm can be checked on the LCD monitor.

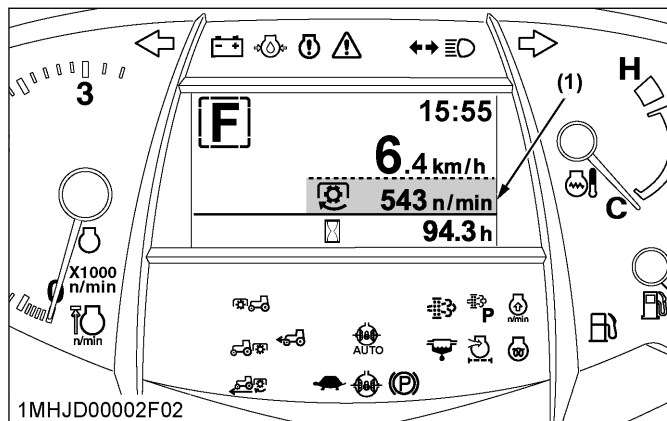

(1) PTO rpm

NOTE :

Interchangeable PTO 540/1000 rpm model

- When the PTO speed is changed from 540 rpm to 1000 rpm, it is necessary to switch the PTO speed display mode. Otherwise, the PTO speed will not be correctly displayed on the LCD monitor. Such mode switching is also needed when returning to the 540 rpm PTO speed. The PTO rpm can be checked on the LCD monitor. (See LCD MONITOR on page 63.)

4. PTO shaft cover and shaft cap

! WARNING

To avoid personal injury or death:

- Keep the PTO shaft cover in place at all times. Put back the PTO shaft cap when the PTO is not in use.
- Before connecting or disconnecting a drive shaft to the PTO shaft, be sure the engine is "OFF" and raise up the PTO shaft cover. Afterward be sure to return the PTO-shaft-cover to the normal position.

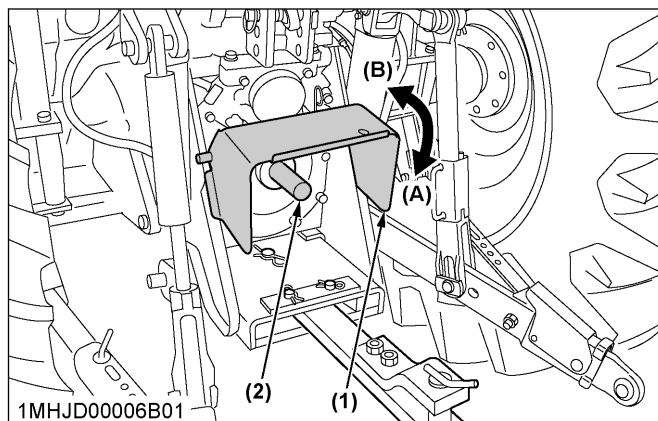

(1) PTO shaft cover (A) "NORMAL POSITION"
 (2) PTO shaft cap (B) "RAISED POSITION"

IMPORTANT :

- The universal joint of the PTO drive shaft is technically limited in its moving angle. Refer to the PTO drive shaft instructions for proper use.

PTO MODELS

1. PTO 540/540E rpm model

1.1 PTO gear shift lever

! WARNING

To avoid personal injury or death:

- Be sure to observe the PTO shaft speed prescribed for the individual implements. It is extremely dangerous to run an implement at high speed that is meant to be operated at low speed. Use only when this higher rpm is specifically recommended by the implement manufacturer.

The PTO gear shift lever can be set to either 540 rpm or 540E rpm positions.

Move this lever to either position with the PTO clutch control switch set to "OFF".

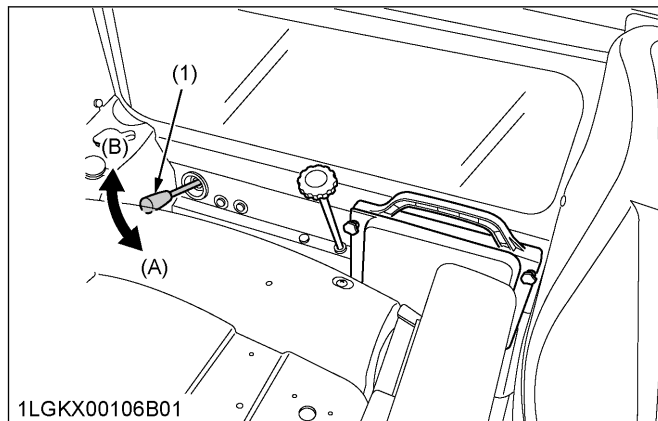

(1) PTO gear shift lever (A) 540 rpm
 (B) 540E rpm

NOTE :

- When light load, select the “540E” position for economical operation.

PTO gear shift lever	Engine speed rpm	PTO speed rpm
540	2035	540
540E	1519	540

1.2 PTO speed limiter

NOTE :

- Move the PTO gear shift lever to “540E” and then turn on the PTO clutch control switch, and the *rev-limiter* indicator lights up on the meter panel.
- If the PTO clutch control switch is turned on with the engine rpm higher than the PTO 540E limit level, the PTO clutch indicator on the meter panel starts blinking and the PTO is disabled. After a while, the engine rpm automatically drops below the PTO 540E limit level and the PTO starts functioning. At the same time, the flashing PTO clutch indicator stays on.
- If the PTO clutch control switch is turned “OFF” but the engine rpm fails to rise with the throttle, return the engine rpm to a lower level. This enables acceleration again.

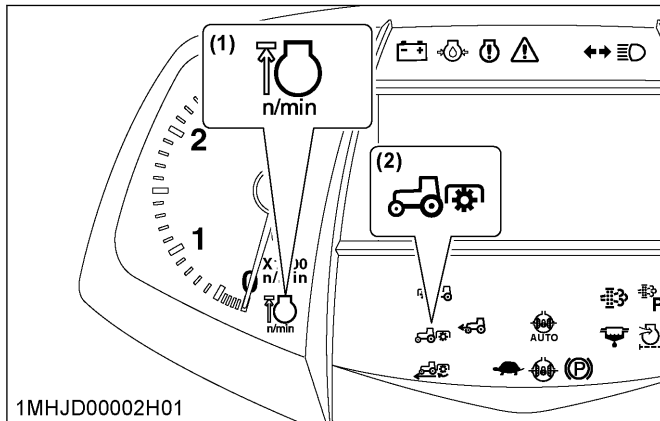

(1) Rev-limiter indicator
(2) PTO clutch indicator

PTO	Limitation PTO/Engine speed (rpm)
540E	630/1772

2. Interchangeable PTO 540/1000 rpm model

2.1 1000 rpm PTO shaft

⚠ WARNING

To avoid personal injury or death:

- Be sure to observe the PTO shaft speed prescribed for the individual implements. It is extremely dangerous to run an implement at high speed that is meant to be operated at low speed. Use only when this higher rpm is specifically recommended by the implement manufacturer.

By interchanging the PTO shafts, 2 different PTO shaft speeds can be obtained.

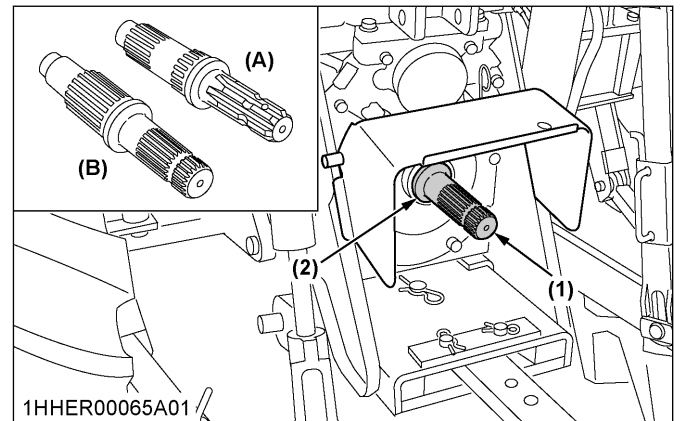

(1) PTO shaft
(2) Snap ring
(A) 540 rpm PTO shaft
(B) 1000 rpm PTO shaft

PTO shaft interchanging procedure

The 6-spline 540 rpm PTO shaft is standard equipment.

1. Place an oil pan under the PTO shaft to catch oil spillage. Remove the snap ring, and then the PTO shaft.
2. Install the 21-spline PTO shaft (1000 rpm). To ensure that it is tight, push it in by turning.
3. Reinsert the snap ring.

IMPORTANT :

- For maximum PTO shaft speeds of various implements, see the implement operator's manual.

	Engine speed rpm	PTO speed rpm
540 rpm PTO shaft	2035	540
1000 rpm PTO shaft	2389	1000

3-POINT HITCH AND DRAWBAR

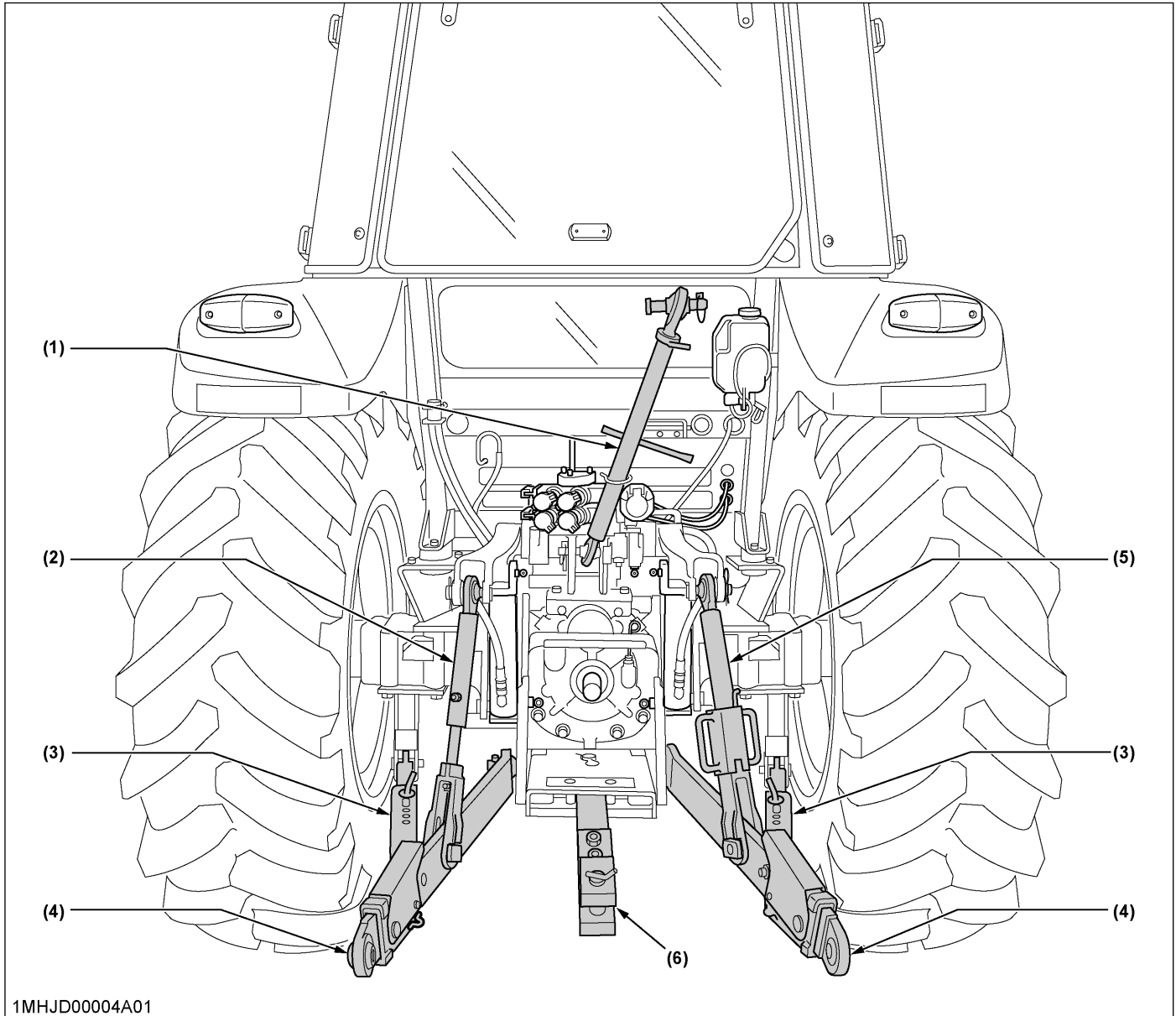

1MHJD00004A01

- (1) Top link
- (2) Lifting rod (left)
- (3) Telescopic stabilizers

- (4) Lower link
- (5) Lifting rod (right)
- (6) Drawbar

THE 3-POINT HITCH SETUP

1. Make preparations for attaching implement.
 - Selecting the holes of lower links on page 79
 - Adjusting lateral float on page 79
2. Attaching and detaching implements.

WARNING

To avoid personal injury or death:

- Be sure to stop the engine.
- Do not stand between the tractor and implement unless both parking brakes are applied.
- Before attaching or detaching the implement, locate the tractor and implement on a firm level surface.
- Whenever an implement or other attachment is connected to the tractor 3-point hitch, check the full range of operation for interference, binding or PTO separation.
- Do not exceed the maximum allowable length of either lifting rod, or the lifting rod will come apart and the 3-point equipment may fall.

- Selecting the top link mounting holes on page 79
- Drawbar on page 80
- Lifting rod (left) on page 80
- Lifting rod (right) on page 80
- Top link on page 80
- Telescopic stabilizers on page 81
- Quick hitch - hook type (if equipped) on page 81

1. Selecting the holes of lower links

There are 2 holes in the lower links. For most operations, the lifting rods should be attached to the (B) hole.

Type A

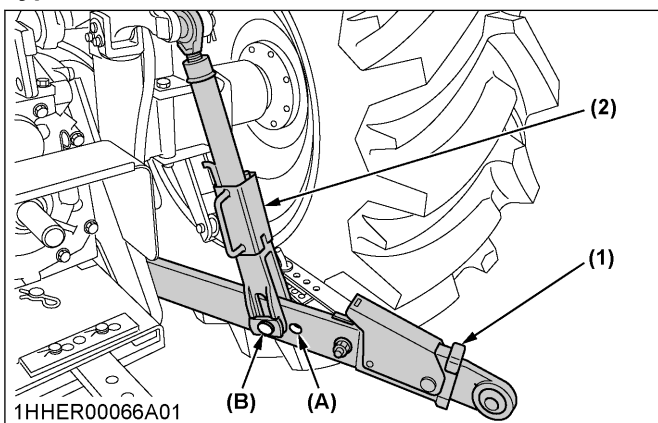

(1) Lower link (A) Hole
(2) Lifting rod (B) Hole

Type B (if equipped)

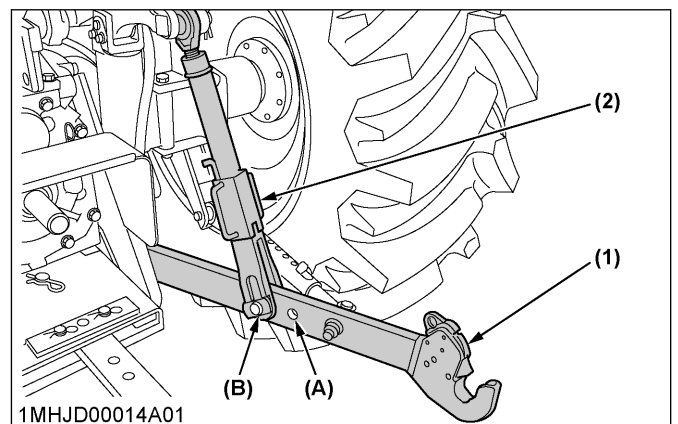

(1) Lower link (A) Hole
(2) Lifting rod (B) Hole

NOTE :

- The lifting rods may be attached to (A) hole for greater lifting force.

2. Adjusting lateral float

To allow the implement to follow the shape of the ground, attach the rectangular washers and pin heads in vertical position.

To hold the implement, reset the rectangular washers and pin heads in horizontal position.

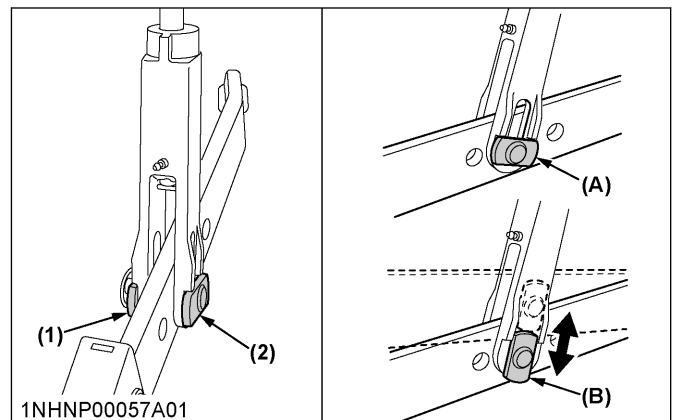

(1) Rectangular washer (A) Horizontal position
(2) Pin head (B) Vertical position

Floating mechanism

When the floating mechanism is used, the implement is able to follow the tractor freely in response to the soil and ground conditions. This is suited for operation with implements wider than the tractor.

3. Selecting the top link mounting holes

Select the proper set of holes.
(See Hydraulic control unit use-reference chart on page 90.)

If the hydraulic unit is set for draft control, the draft response is more sensitive when an implement is connected to the lower set of top link mounting holes. If draft control is not required, it is recommended to use the top set (1).

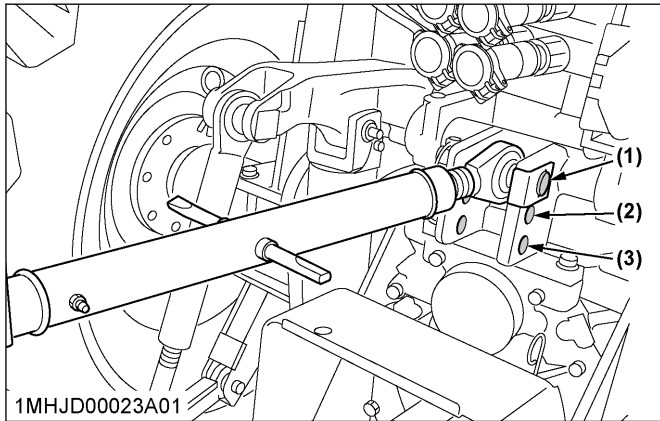

1MHJD00023A01
 (1) Hole set 1 (selection example)
 (2) Hole set 2
 (3) Hole set 3

4. Drawbar

Remove the drawbar if a close-mounted implement is attached.

5. Lifting rod (left)

By turning the rod itself, the lifting rod varies its length. When extending the rod, do not exceed the groove on the rod thread.

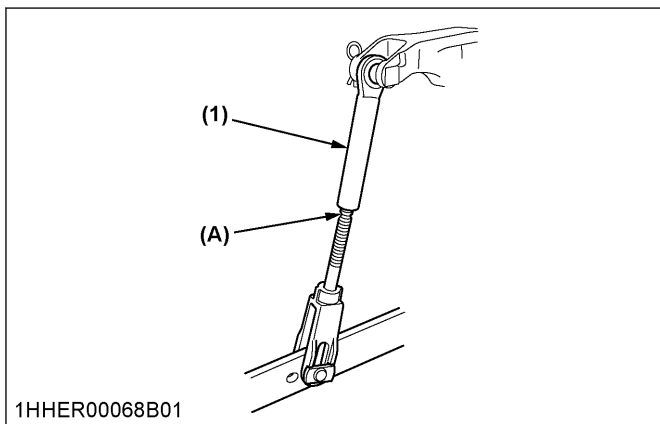

1HHER00068B01
 (1) Lifting rod (A) "GROOVE"

6. Lifting rod (right)

! WARNING

To avoid personal injury or death:

- Do not extend lifting rod beyond the groove on the threaded rod.

- To adjust the length of the lifting rod, lift the adjusting handle and turn to desired length.
- After adjusting, lower the lifting rod adjusting handle to the lock position.
- When extending the rod using the adjusting handle, do not exceed the groove on the rod thread.

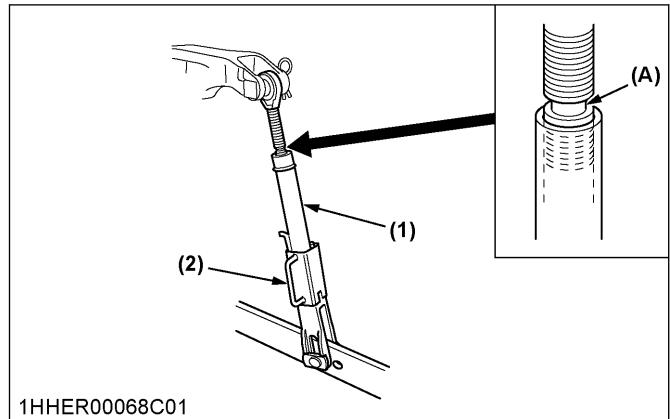

1HHER00068C01
 (1) Lifting rod (A) "GROOVE"
 (2) Adjusting handle

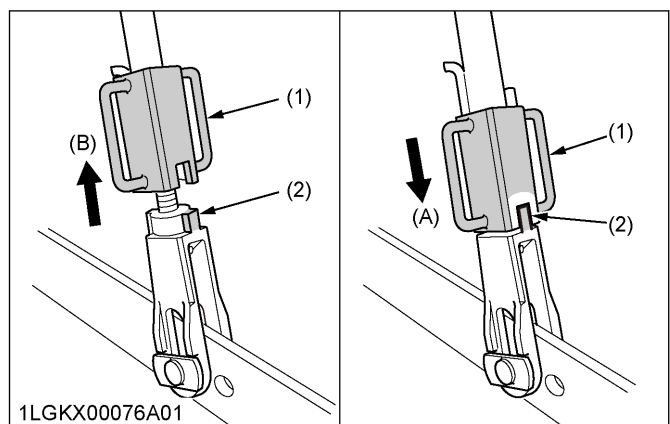

1LGKX00076A01
 (1) Adjusting handle (A) "LOCK POSITION"
 (2) Lock pin (B) "UNLOCK POSITION"

7. Top link

! WARNING

To avoid personal injury or death:

- When extending the top link, do not exceed the groove on the top link thread, or the top link will come apart and the 3-point equipment may fall.

- Adjust the angle of the implement to the desired position by shortening or lengthening the top link.

- The proper length of the top link varies according to the type of implement being used.

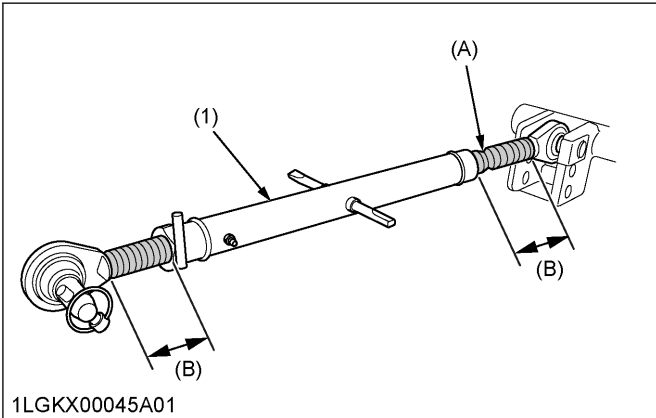

(1) Top link
 (A) "GROOVE"
 (B) "Length of the screw"

NOTE :

- The length of the screw at both ends of the top link must be the same always.

8. Telescopic stabilizers

- Adjust the telescopic stabilizers to control horizontal sway of the implement. Select the proper set of holes. (See Hydraulic control unit use-reference chart on page 90.)
- After aligning satisfactorily, insert the set-pin through any one of the holes on the outer tube that align with one of the holes on the inner bar and both stabilizers will be locked. If the set-pin is inserted through the slot to engage one of the holes on the inner bar, a limited degree of sway will be permitted.

5-hole type stabilizer

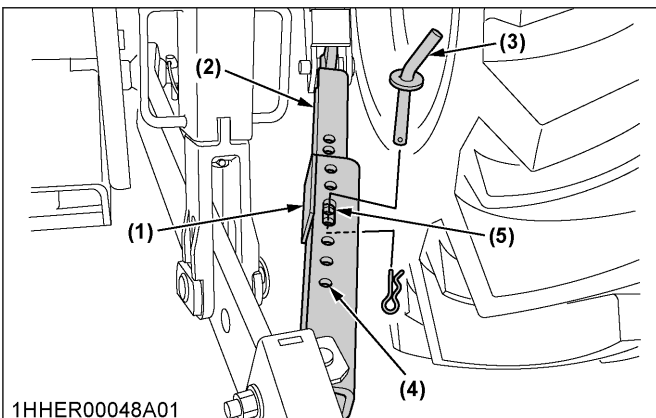

(1) Outer tube
 (2) Inner bar
 (3) Set-pin
 (4) Hole
 (5) Slot

6-hole type stabilizer (if equipped)

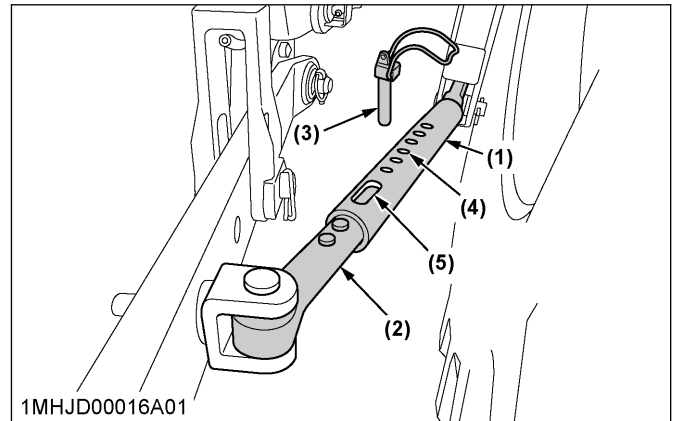

(1) Outer tube
 (2) Inner bar
 (3) Set-pin
 (4) Hole
 (5) Slot

8.1 Telescopic lower links

To attach an implement, follow the instructions below:

- Push the levers, pull out the lower link ends, and attach to the implement.
- Back up the tractor slightly to make sure the lower links are pushed in securely.

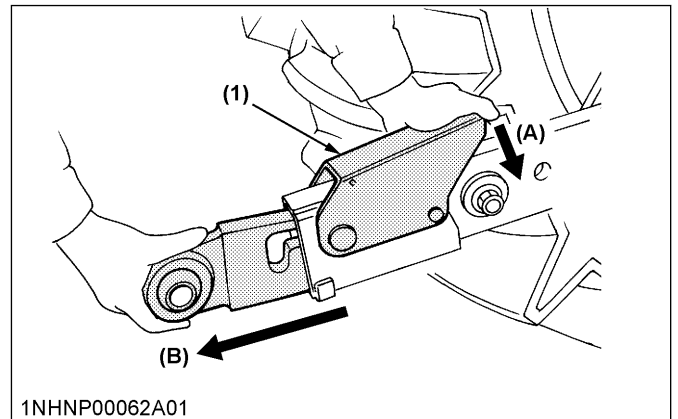

(1) Lever
 (A) "PUSH"
 (B) "PULL OUT"

9. Quick hitch - hook type (if equipped)

⚠ WARNING
 To avoid personal injury or death:
 Confirm the below when installing the implement:
 • Make sure the hook of the quick hitch is securely locked.

The 3-point hitch with quick-hitch, all of which have claw ends that permit rapid attaching and detaching of implements.

9.1 Installing ball-joint to implement

1. Before the implement is installed on the 3-point hitch with quick hitches, it is necessary to install the ball-joints to the implement according to the following instructions.

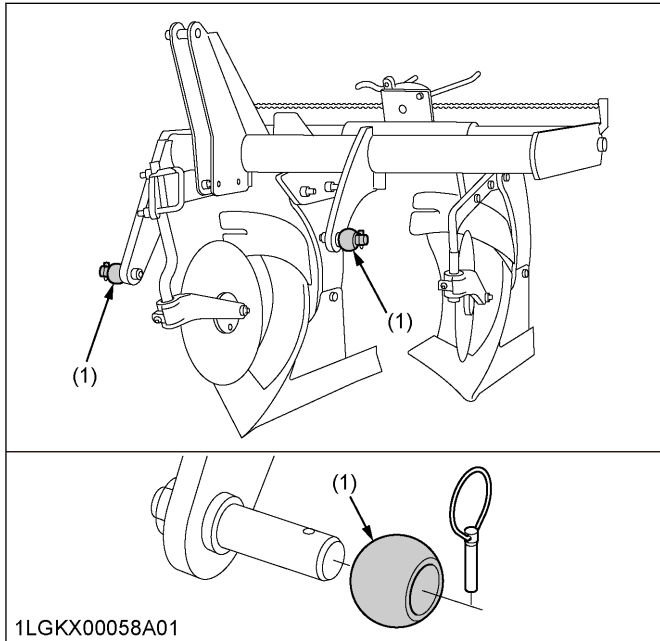

1LGKX00058A01

(1) Ball-joint

9.2 Adjusting lower link width

1. Set the width (W1) of lower links to be the same as width (W2) of the implement. Details regarding the adjustment of the width (W1) of lower links can be found in a different section. (See Telescopic stabilizers on page 81.)

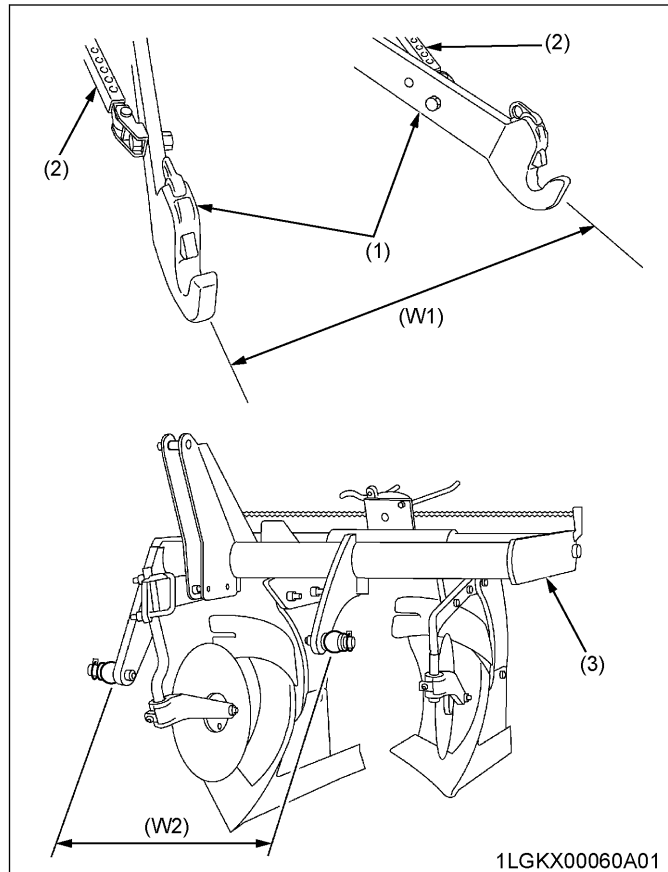

1LGKX00060A01

(1) Lower link
(2) Telescopic stabilizer
(3) Implement

9.3 Attaching implement to tractor

1. Set the release lever on the quick hitches to "LOCK" position, if its lever is in "UNLOCK" position (self-locking latches are closed).
2. With the lower links fully lowered, reverse the tractor until the quick hitches are beneath the implement ball-joints.
3. Raise the lower links using the hydraulic control lever until the quick hitches engage the ball-joints.

NOTE :

- An audible click will be heard as the self-locking latches engage the implement ball-joint.

4. Connect the top link to the implement. If necessary, adjust the top link length.

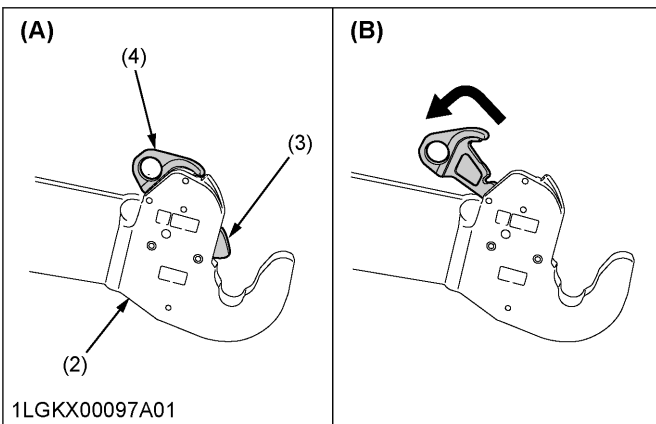
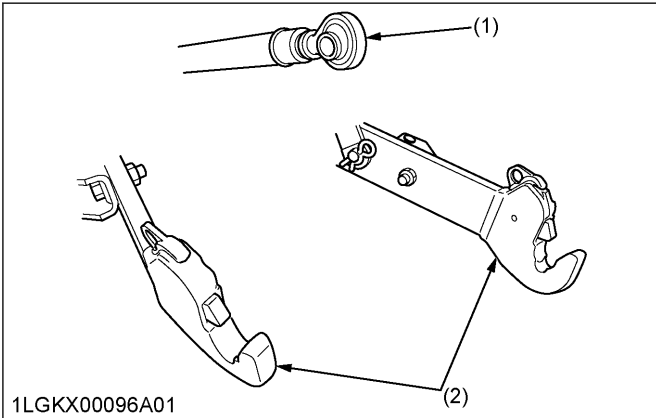

- | | |
|-------------------|-----------------------|
| (1) Top link | (A) "LOCK" position |
| (2) Lower link | (B) "UNLOCK" position |
| (3) Latch | |
| (4) Release lever | |

9.4 Detaching implement from tractor

1. Fully lower the implement to the ground. Support the implement with parking stand (if equipped). If necessary, adjust the top link and or lifting rod length so that the implement may stabilize on the ground.
2. Detach the top link from implement. Hook the top link in the top link support.
3. Pull the release levers on both lower links to release the quick hitches from implement ball-joints. The latches will disengage and allow the lower links to lower and detaching the implement.

DRAWBAR

WARNING

To avoid personal injury or death:

- Never pull from the top link, the rear axle or any point above the drawbar. Doing so could cause the tractor to tip over rearward.

1. Adjusting drawbar length

1. When towing an implement, it is recommended that hole (A) in drawbar be utilized.
2. For information about the drawbar load, read the implement limitations section of this manual. (See IMPLEMENT LIMITATIONS on page 27.)

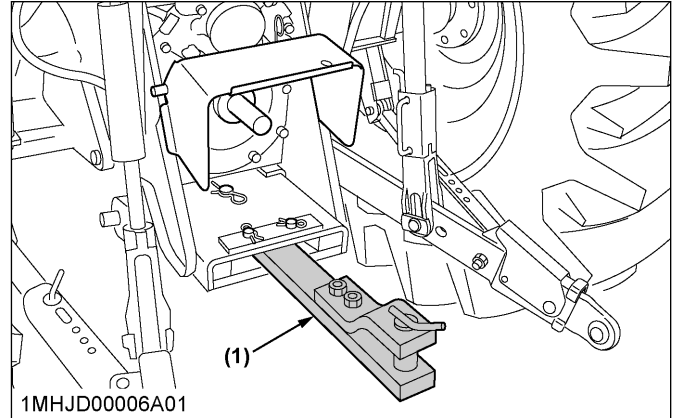

(1) Drawbar

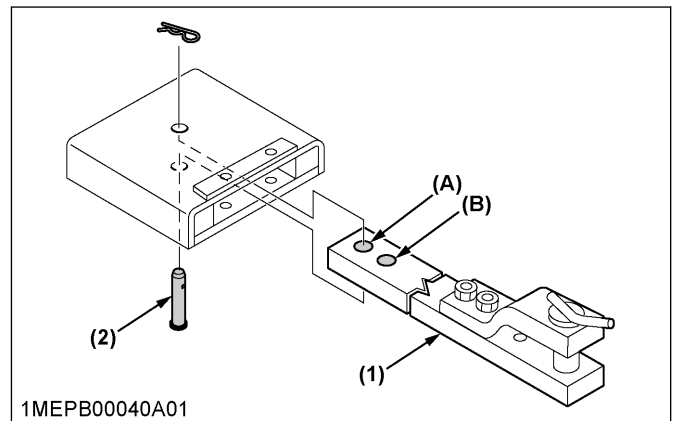

(1) Drawbar	(A) Hole
(2) Pivot pin	(B) Hole

2. Swing drawbar

The drawbar can be used in 3 different ways as shown in the following illustration. Assemble it correctly with locating pins.

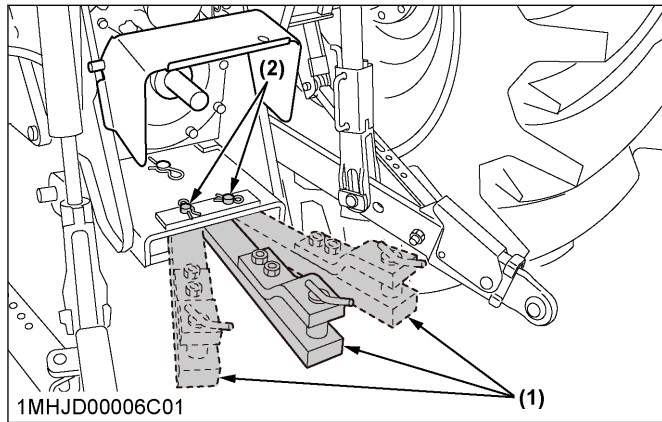

- (1) Drawbar
- (2) Locating pin

HYDRAULIC UNIT

IMPORTANT :

- Do not operate until the engine is warmed up. If any operation is attempted when the engine is still cold, the hydraulic system may be damaged.
- If noises are heard when the implement is lifting after the hydraulic control lever has been activated, the hydraulic mechanism is not adjusted properly. Unless corrected, the unit will be damaged. Contact your KUBOTA Dealer for adjustments.

A standard tractor has the following hydraulic control systems. Choose the most appropriate system for the implement you are using.

3-point hitch control system

- Position control
- Draft control
- Mixed control
- Float control

Remote hydraulic control system

3-POINT HITCH CONTROL SYSTEM

⚠ WARNING

To avoid personal injury or death:

- Before using the 3-point hitch controls, ensure that no person or object is in the area surrounding the implement or 3-point hitch. Do not stand on or near the implement or between the implement and tractor when operating the 3-point hitch controls.

1. Position control

This will control the working depth of the 3-point hitch mounted implement regardless of the amount of pull required.

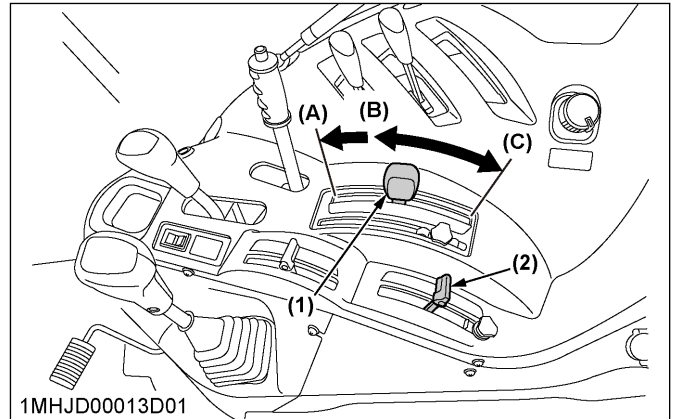

1MHJD00013D01

- | | |
|----------------------------|-------------|
| (1) Position control lever | (A) "FLOAT" |
| (2) Draft control lever | (B) "DOWN" |
| | (C) "UP" |

2. Draft control

This will control the pull of the 3-point implement. As the load on the 3-point hitch changes due to various soil conditions, the draft control system automatically responds to these changes by either raising or lowering the implement slightly to maintain a constant pull. Place the position control lever in the lowest position and set the implement pull with the draft control lever.

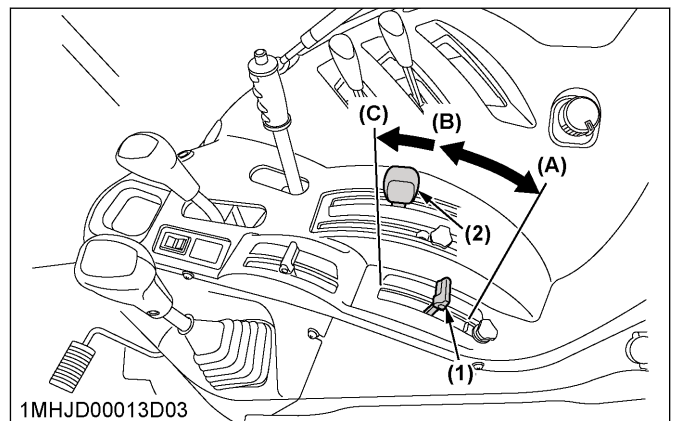

1MHJD00013D03

- | | |
|----------------------------|-------------------|
| (1) Draft control lever | (A) "SENSITIVE" |
| (2) Position control lever | (B) "INSENSITIVE" |
| | (C) "FLOAT" |

3. Mixed control

In draft control, when draft decreases, the implement automatically lowers to increase draft. However, the implement sometimes lowers too much. To limit the degree to which the implement can be lowered, set the position control lever at the lowest working depth desired for the implement. Lower the

draft control lever to the point where the implement is at the desired depth.

This stops the implement from going too deep and causing loss of traction and ground speed.

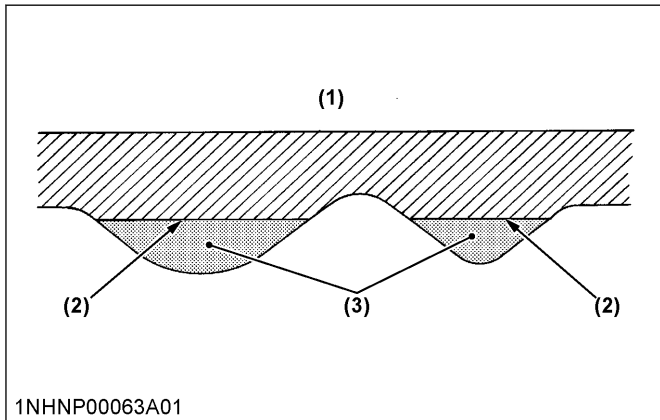

1NHNP00063A01

- (1) Ground surface
- (2) Implement penetration limit
- (3) Light soil

4. Float control

Place both the draft control lever and the position control lever in the float position to make the lower links move freely along with the ground conditions.

5. 3-point hitch lowering speed knob

WARNING

To avoid personal injury or death:

- A fast lowering speed may cause damage or injury. The lowering speed of the implement should be adjusted to 2 or more seconds.

The lowering speed of the 3-point hitch can be controlled by adjusting the 3-point hitch lowering speed knob.

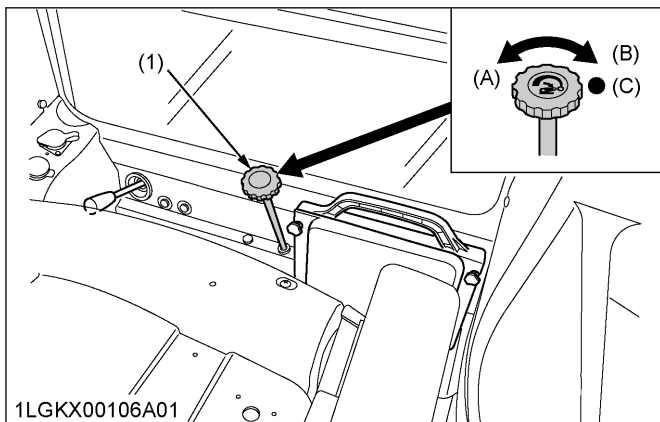

1LGKX00106A01

- (1) 3-point hitch lowering speed knob
- (A) "FAST"
- (B) "SLOW"
- (C) "LOCK"

REMOTE HYDRAULIC CONTROL SYSTEM

The hydraulic auxiliary control valves can be installed with up to 3 segments.

It is not possible to use triple segments with flow control valve.

1. Remote control valve

There are 3 types of remote valves available for these models.

- Double acting valve with detents and self-canceling: This valve may be placed in the detent mode. The lever will stay in this position until the pressure reaches a predetermined level or a cylinder reaches the end of its stroke. Then it will automatically return to neutral.
- Double acting valve with float position: This valve may be placed in the float mode with the control lever all the way forward. The cylinder is free to extend or retract, letting an implement such as a loader bucket follow the ground.
- Single or double acting valve: This valve can be utilized as single or double acting valve by adjusting the auxiliary control valve selector knob located on the valve.
 1. Turn the auxiliary control valve selector knob clockwise all the way to utilize as single acting valve.
 2. Turn the auxiliary control valve selector knob anticlockwise all the way to utilize as double acting valve.

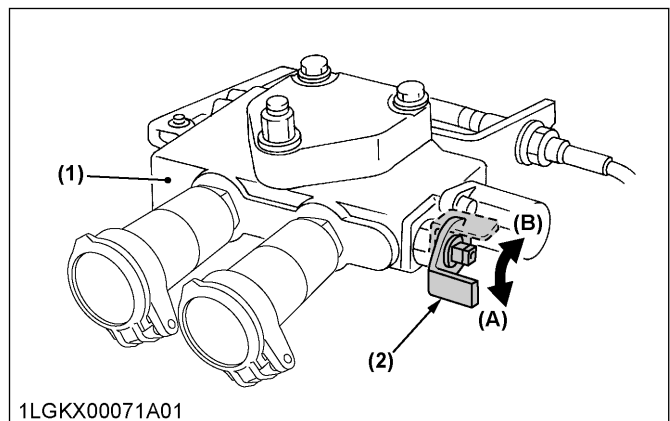

1LGKX00071A01

- (1) Single or double acting valve
- (2) Auxiliary control valve selector knob
- (A) Double acting
- (B) Single acting

2. Remote control valve lever

The remote control valve lever directs pressurized oil flow to the implement hydraulic system.

Example: Installing triple segment valves

1st	Single or double acting valve (standard)
2nd	Double acting valve with detents and self-canceling (standard)
3rd	Double acting valve with float position (option)

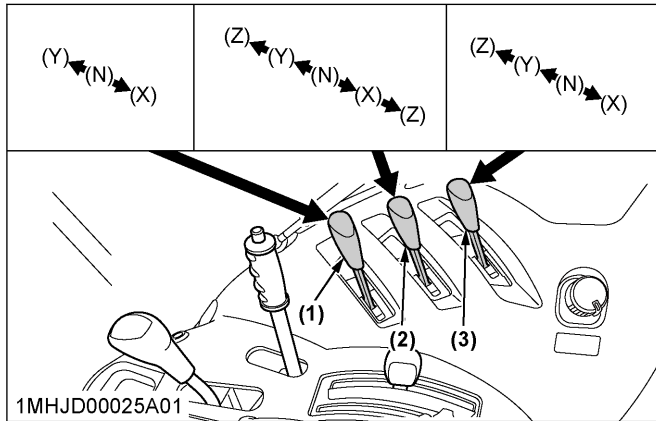

- (1) Remote control valve lever 1
- (2) Remote control valve lever 2
- (3) Remote control valve lever 3

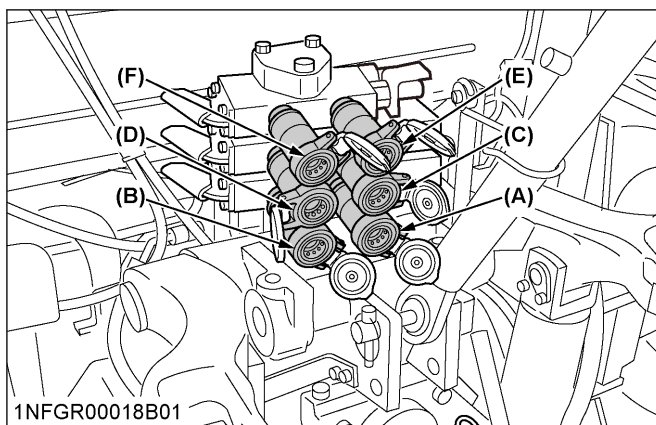

Pressure →
Returning ←

Lever 1	Double-acting		Single-acting		
	Lever position				
	Y	X	Y	X	
Port	(A)	out →	in ←	-	-
	(B)	in ←	out →	in ←	out →

Lever 2	Lever position			
	Z (detent)	Y	X	Z (detent)
	Port	(C)	out →	
(D)		in ←		out →

Lever 3	Lever position				
	Z (detent)		Y	X	
Port	(E)	in	Float	out →	in ←
	(F)	out		in ←	out →

IMPORTANT :

- Do not hold the lever in the “Pull” or “Push” position once the remote cylinder has reached the end of the stroke, as this will cause oil to flow through the relief valve. Forcing oil through the relief valve for extended periods will overheat the oil.
- When using the tractor hydraulic system to power the front loader, do not operate the boom and bucket cylinders simultaneously.

NOTE :

- Connect the pressure of load side of implement cylinders to ports (B), (D) or (F) which have built-in load check valves to prevent leakage.
- To use the single-acting cylinder with the float valve, connect this cylinder to the (B), (D) or (F) port.
To extend a single-acting cylinder, pull the remote control valve lever rearward. To retract a cylinder, push it fully forward to the “FLOAT” position. Do not hold it in the down position or the transmission fluid may overheat.

3. Remote control valve coupler

⚠ WARNING

To avoid personal injury or death:

- Stop the engine and relieve pressure before connecting or disconnecting lines.
- Do not use your hands to check for leaks.

Connecting

1. Clean both couplers.
2. Remove dust plugs.
3. Insert the implement coupler into the tractor hydraulic coupler.
4. Pull the implement coupler slightly to make sure couplers are firmly connected.

Disconnecting

1. Lower the implement to the ground to release hydraulic pressure from the hoses.
2. Clean the couplers.
3. Relieve pressure by moving hydraulic control levers with engine shut off. Pull the hose straight from the hydraulic coupler to release it.
4. Clean oil and dust from the coupler, then replace the dust plugs.

NOTE :

- Your local KUBOTA Dealer can supply parts for adapting couplers to hydraulic hoses.

4. Flow control valve (option)

The optional flow control valve may be added for the following purposes.

1. To operate within limits, the remote control valve (2) above the flow control valve (3) and the 3-point hitch at the same time without one affecting the other.
2. To operate within limits, the remote control valve (2) above the flow control valve (3) and the other remote control valve (1) at the same time without one affecting the other. Activating the remote control valve (1) will interrupt the operation of the 3-point hitch.
3. To maintain within limits, the constant speed of an attachment (hydraulic motor rpm, for example) when connected to the remote control valve (2) above the flow control valve (3).

NOTE :

- At lower engine speeds the total hydraulic flow rate may be inadequate for simultaneous operation of the remote control valve (2) and the 3-point hitch or the remote control valve (1), or operation of an attachment connected to the remote control valves (1)(2). Under these conditions, the engine speed must be increased to provide additional hydraulic flow.

4.1 Adjusting the flow rate

⚠ WARNING

To avoid the possibility of personal injury or death be aware of the following when making adjustments:

- The 3-point hitch operation is influenced by the combination of the adjustment of the flow control valve and the engine speed.
- The 3-point hitch may rise slowly or not at all at low engine rpm.
- The 3-point hitch may rise suddenly if engine rpm is increased, or, flow control adjustment is changed.

Refer to the following illustration.

1. The flow rate for the remote control valve (2), located on above the flow control valve (3), can be adjusted.
2. Turn the flow control knob (4) counterclockwise (A), and the flow rate for the remote control valve (2) increases. A clockwise turn (B) of the knob causes

the flow to decrease. If the knob is turned all the way (C), there will be no flow.

3. To adjust the flow rate, set the engine speed to the operating rpm, turn the flow control knob once all the way clockwise (C), and then turn it gradually counterclockwise until a required flow rate is reached.

NOTE :

- Full adjustment of the valve will occur in approximately 1 1/2 revolutions of the flow control knob. Turning the flow control knob beyond this point will have no effect on the flow rate.

IMPORTANT :

- When there is no need to adjust the flow rate, turn the flow control knob all the way counterclockwise and keep it in this position.

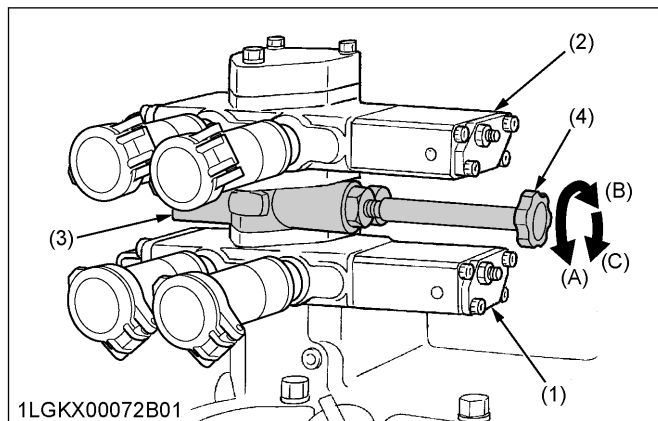

(1) Remote control valve (1) (A) "INCREASE"
 (2) Remote control valve (2) (B) "DECREASE"
 (3) Flow control valve (C) "STOP"
 (4) Flow control knob

4.2 Positions and advantages of the flow control valve

Refer to the following illustration.

Position 1

1. The attachment control speed (hydraulic motor rpm, for example) of the remote control valve (1) can be maintained at a constant level within limits.
2. The remote control valve (1) and the 3-point hitch can be operated at the same time. The 3-point lift speed will be influenced by the level of flow required at remote control valve (1).

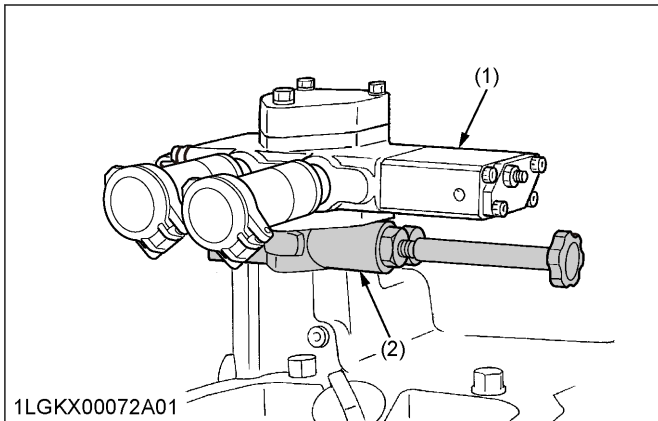

- (1) Remote control valve (1)
- (2) Flow control valve

Position 2

1. The attachment control speed (hydraulic motor rpm, for example) of the remote control valve (2) can be maintained at a constant level.
2. The remote control valve (2) and the 3-point hitch can be operated at the same time with the speed of the 3-point hitch being influenced by the adjustment range of the flow control valve.
3. Remote control valves (1) and (2) can be operated at the same time with operation of the 3-point hitch being interrupted by activation of valve (1).
4. The operation of valve (1) is influenced by the flow adjustment to valve (2).
5. The 3-point hitch lift speed and the flow available for valve (1) are influenced by the flow adjustment of valve (2).

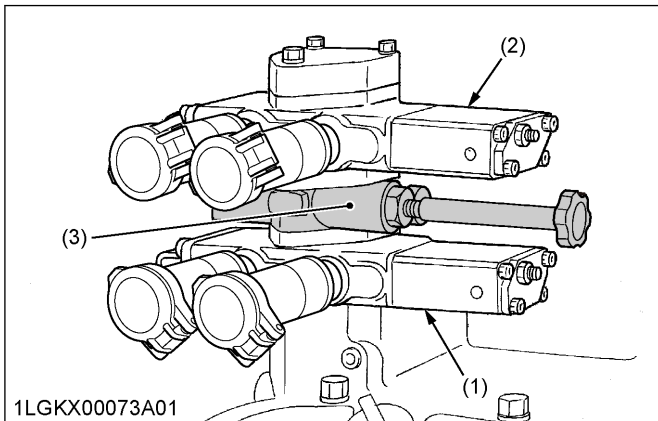

- (1) Remote control valve (1)
- (2) Remote control valve (2)
- (3) Flow control valve

5. Hydraulic control unit use-reference chart

In order to handle the hydraulics properly, the operator must be familiar with the following. Although this information may not be applicable to all types of implements and soil conditions, it is useful for general conditions.

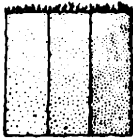
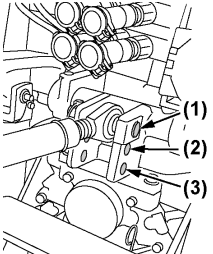
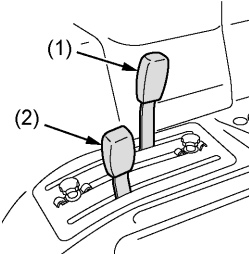
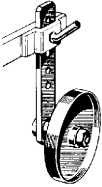
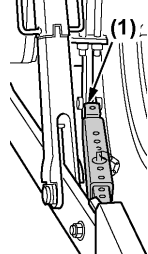
Implement	 1AGAIAZAP122A Soil condition	 1MHJD00023B01 Top link mounting holes	 1NHNP00050B01 (1) Position control lever (2) Draft control lever	 1AGAIAZAP070A Gauge wheel	 1NHNP00069A01 (1) Telescopic stabilizer	Remarks
Moldboard plow	Light soil Medium soil Heavy soil	3 2 or 3 2	Draft and mixed control (place the draft control lever to the suitable position and set the implement pull with the position control lever).	Yes/No	Loose	Insert the set-pin through the slot on the outer tube that aligns with one of the holes on the inner bar. For implements with gauge wheels, lower the position control lever fully.
Disc plow	---	2 or 3				
Harrow (spike, spring-tooth, disc type)	---	2				
Subsoiler, etc.	---	2				
Weeder, ridger, etc.	---	1	Position control (hold the draft control lever at the frontmost position during operation).	Yes	Tighten	Telescopic stabilizer should be tight enough to prevent excessive implement movement when implement is in raised position. For implements with gauge wheels, lower the position control lever fully.
Earth mover, digger, scraper, manure fork, rear carrier, etc.	---	1		Yes/No		
Mower (mid-and rear-mount type) Hay rake, tedder, etc.	---	1		No		

TIRES, WHEELS AND BALLAST

TIRES

 **WARNING**

To avoid personal injury or death:

- Do not attempt to mount a tire on a rim. This should be done by a qualified person with the proper equipment.
- Always maintain the correct tire pressure. Do not inflate tires above the recommended pressure shown in the operator's manual.

IMPORTANT :

- Do not use tires other than those approved by KUBOTA.

NOTE :

- When optional different-diameter tires are fitted on the machine, the travel speed display mode must be changed. Otherwise, the travel speed will not be correctly displayed. Such mode switching is also needed when the original tires are back on the machine.
(See Setting the tire circumference on page 65.)

1. Inflation pressure

Although the tire pressure is factory-set to the prescribed level, it naturally drops slowly in the course of time. Thus, check it every day and inflate as necessary.

NOTE :

- Maintain the maximum pressure in front tires if using a front loader or when equipped with a full load of front weights.

	Tire size	Inflation pressure
Front	320/85R20	160 kPa (1.6 kgf/cm ²)
	320/70R24	160 kPa (1.6 kgf/cm ²)
	360/70R24	160 kPa (1.6 kgf/cm ²)
	320/85R24	160 kPa (1.6 kgf/cm ²)
	380/70R20	160 kPa (1.6 kgf/cm ²)
Rear	420/85R30	160 kPa (1.6 kgf/cm ²)
	460/85R30	160 kPa (1.6 kgf/cm ²)
	420/85R34	160 kPa (1.6 kgf/cm ²)
	480/70R34	160 kPa (1.6 kgf/cm ²)
	340/85R38	160 kPa (1.6 kgf/cm ²)
	480/70R30	160 kPa (1.6 kgf/cm ²)

2. Dual tires

Dual tires are not approved.

WHEEL ADJUSTMENT

 **WARNING**

To avoid personal injury or death:

- When working on slopes or when working with a trailer, set the wheel tread as wide as practical for maximum stability.
- Support the tractor securely on stands before removing a wheel.
- Do not work under any hydraulically supported devices. They can settle, suddenly leak, or be accidentally lowered. If necessary to work under the tractor or any machine elements for servicing or adjustments, securely support them with stands or suitable blocking beforehand.
- Never operate the tractor with a loose rim, wheel or axle.

1. Front wheels-4WD

Front tread width can be adjusted as shown with the standard equipped tires.

To change the tread width:

1. Remove the wheel rim and disk mounting bolts.
2. Change the position of the rim and tire to the desired position, and tighten the bolts.
3. Adjust the toe-in as 2 to 8 mm.
(See Adjusting toe-in on page 123.)

IMPORTANT :

- Always attach wheels as shown in the drawing.
- If not attached as illustrated, transmission parts may be damaged.
- When re-fitting or adjusting a wheel, tighten the bolts to the following torques then recheck after driving the tractor 200 m and 10 times of shuttle movement by 5 m, and thereafter according to service interval.

(See MAINTENANCE on page 105.)

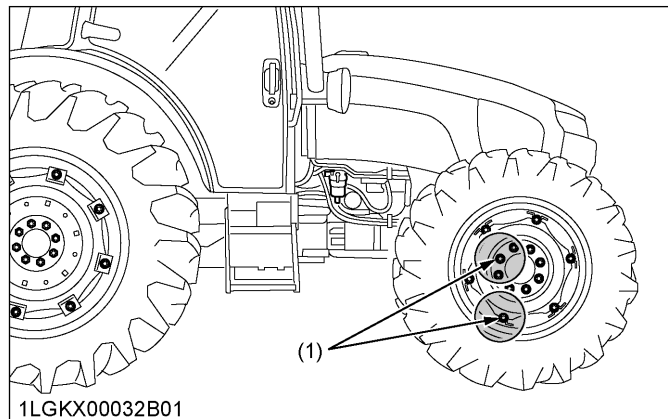

(1) 260 to 304 N · m / 26.5 to 31 kgf · m

320/85R20	1567 mm	1654 mm	---	---	---
320/70R24	---	---	1560 mm	1613 mm	---
320/85R24	---	---	---	1611 mm	---
320/85R24*1	---	1628 mm	---	---	---
360/70R24	---	---	---	1611 mm	---
380/70R20	---	---	1588 mm	---	1615 mm

- (1) Front wheel disc
- (2) Front wheel rim
- (3) Tread

*1 Part No. W23TK01141 only

1.1 Front jack point

WARNING

To avoid personal injury or death:

- Before jacking up the tractor, park it on a firm and level ground and chock the rear wheels.
- Fix the front axle to keep it from pivoting.
- Select jacks that withstand the machine weight and set them up as follows.

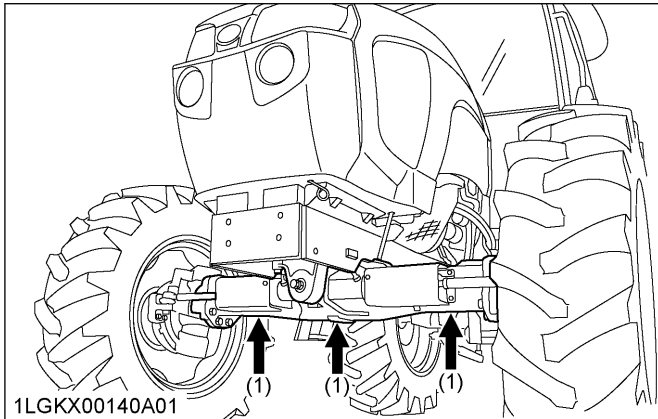

(1) Jack point

2. Rear wheels

Rear tread width can be adjusted as shown with the standard equipped tires.

To change the tread width

1. Remove the wheel rim and/or disk mounting bolts.
2. Change the position of the rim and/or disk (right and left) to the desired position, and tighten the bolts.

IMPORTANT :

- Always attach wheels as shown in the drawing.
- If not attached as illustrated, transmission parts may be damaged.
- When re-fitting or adjusting a wheel, tighten the bolts to the following torques then recheck after driving the tractor 200 m and 10 times of shuttle movement by 5 m, and thereafter according to service interval.

(See MAINTENANCE on page 105.)

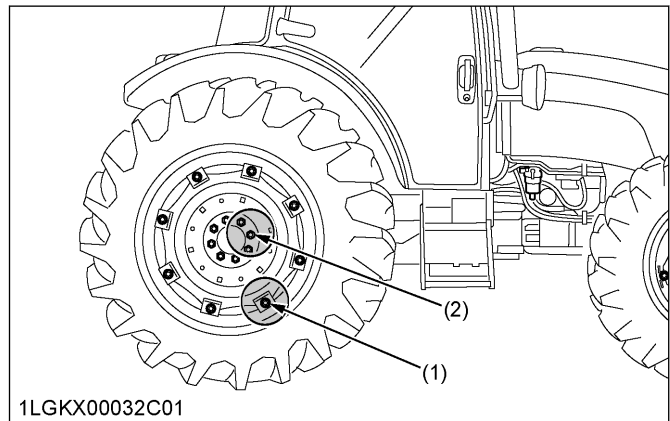

- (1) 260 to 304 N · m / 26.5 to 31.0 kgf · m
 (2) 343 to 401 N · m / 35.0 to 41.0 kgf · m

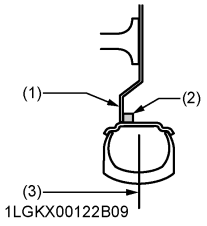
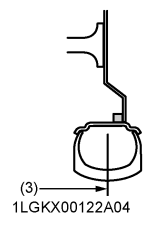
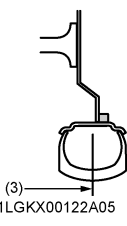
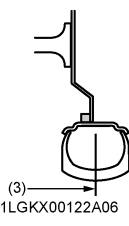
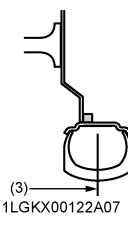
					
420/85R30	1499 mm	1599 mm	1691 mm	---	---
460/85R30	1499 mm	1599 mm	1691 mm	---	---
420/85R34	1503 mm	1599 mm	1695 mm	---	---
480/70R34	1503 mm	1599 mm	1695 mm	---	---
340/85R38	1442 mm	1660 mm	1714 mm	1788 mm	1842 mm
480/70R30	1499 mm	1599 mm	1691 mm	---	---

- (1) Rear wheel disc
 (2) Rear wheel rim
 (3) Tread

2.1 Rear jack point

WARNING

To avoid personal injury or death:

- Before jacking up the tractor, park it on a firm and level ground and chock the front wheels.
- Fix the front axle to keep it from pivoting.
- Select a jack that withstands the machine weight and set it up as follows.

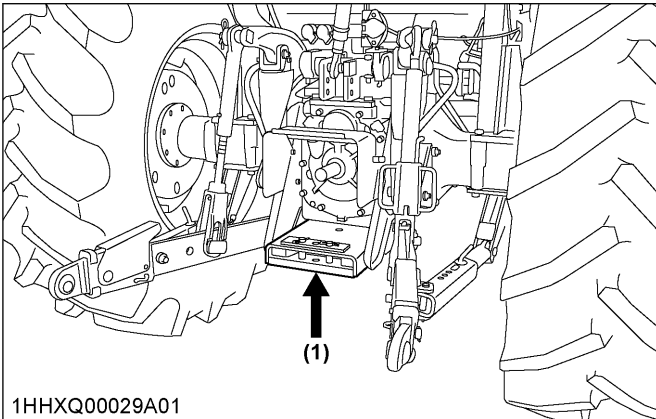

(1) Jack point

CAB OPERATION

CAB CLASSIFICATION AND MAINTENANCE

The CAB fulfills the requirements of category type 2, as defined EN 15695-1.

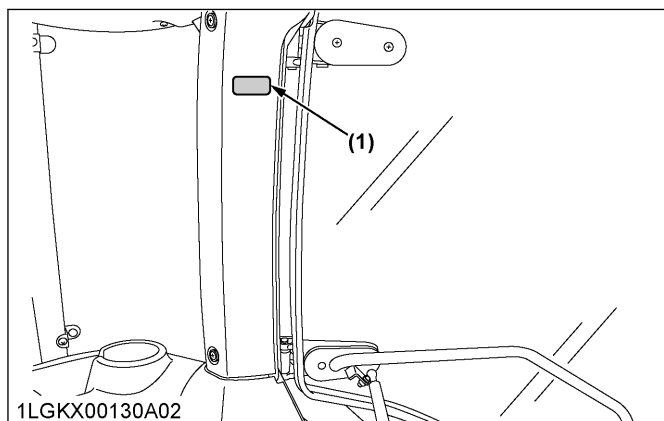

(1) CAB classification label

The air delivery and filtration system of the category 2 CAB protects against airborne and sedimented solid particles.

The system increases the pressure in the CAB, which helps prevent dust from entering the CAB. As additional protection against dust, the category 2 CAB is also equipped with a fresh air filter (EN15695-2).

However, in order for the filtration system to function as intended, the following conditions must be met:

- Door and window seals in good condition.
- Doors and windows closed.
- CAB grommets for cables properly sealed.
- Blower switch set to highest setting and mode switch set to .
- CAB air filters in good condition.

Make sure to follow the available instructions of the personal protective equipment (PPE), plant protection products (PPP), sprayer manufacturer and the national guidelines for worker safety and health regarding, for example:

- Using PPE
- Training and education
- Keeping used PPP out of the CAB
- Removing contaminated shoes or clothing before entering the CAB
- Keeping the CAB interior clean
- Disposal of filters

Clean the inner air filter and fresh air filter at the required service intervals to assure that the category 2 delivery and filtration system is functioning as intended.

(See Cleaning inner air filter on page 123.)

(See Cleaning fresh air filter on page 124.)

DOORS AND WINDOWS

1. Locking and unlocking the door

“From the outside”

Insert the key into the door lock. Turn the key clockwise to unlock the door. To lock the door, turn the key in the opposite direction.

The key can be removed when it is in the vertical position.

“From the inside”

Push down the lock knob to lock the door.

Pull up the lock knob to unlock the door.

2. Opening the door

“From the outside”

Unlock the door, and pull the outer door handle.

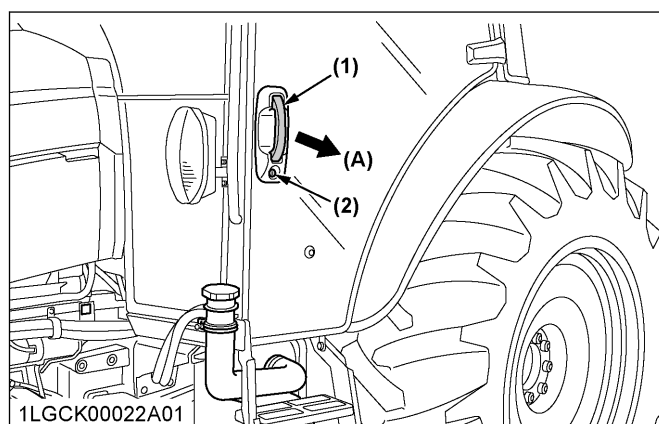

(1) Outer door handle

(2) Door lock

(A) “PULL”

“From the inside”

Unlock the door and pull the inner door handle.

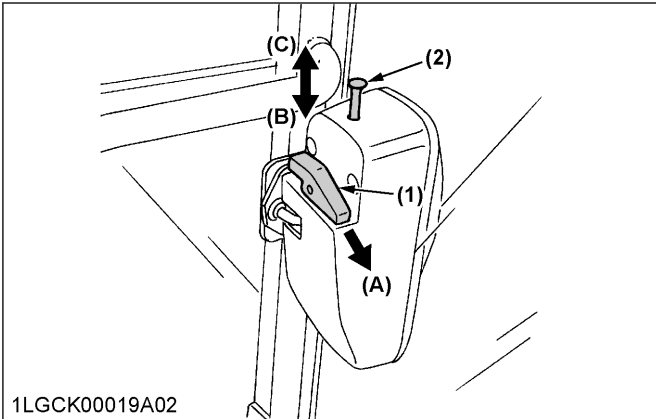

1LGCK00019A02
 (1) Inner door handle (A) "PULL"
 (2) Lock knob (B) "PUSH" (Lock)
 (C) "PULL" (Unlock)

3. Rear window

Turn the rear window handle clockwise to the vertical position and push the handle. The rear window is opened by the gas spring cylinder.

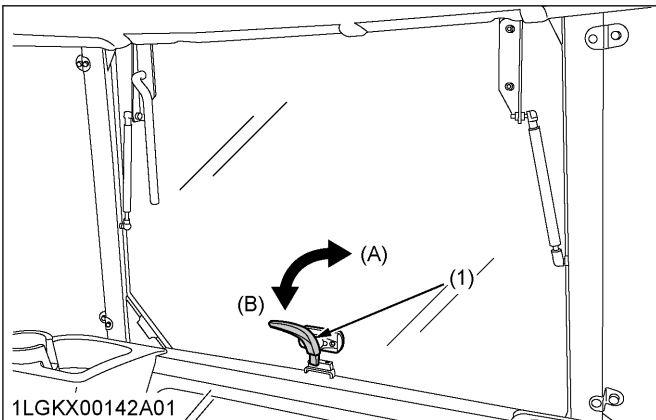

1LGKX00142A01
 (1) Rear window handle (A) "OPEN"
 (B) "CLOSE"

4. Side window

Pull the side window handle and push the side window to open.

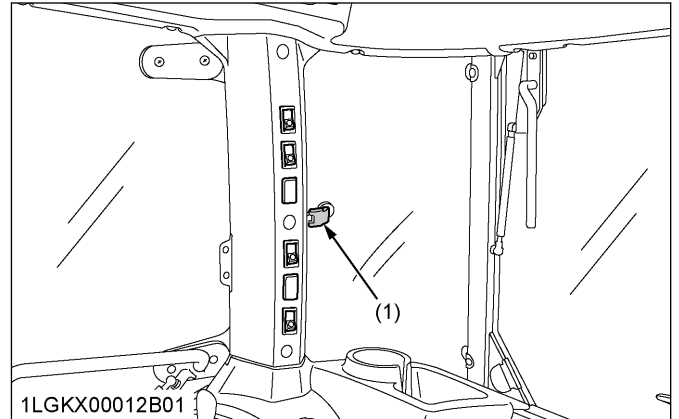

1LGKX00012B01
 (1) Side window handle

5. Sunroof

Raise the front loader, and visually check to see if the tip of an attachment (bucket and fork, for example) is visible in its position or angle from the operator's seat.

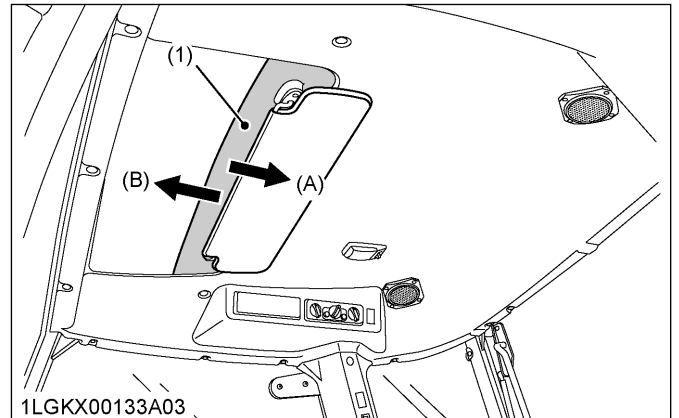

1LGKX00133A03
 (1) Sunroof (A) "OPEN"
 (B) "CLOSE"

NOTE :

- Open and close with the near center of the sunroof.

6. Emergency exit

1. In an emergency situation, open the right door of the CAB if the left door is blocked and vice versa.
2. Exit through the rear window if the CAB doors are blocked.

DOMELIGHT

Sliding the dome light switch will give the following light condition:

[OFF]

The light does not turn on when the door is opened.

“DOOR”

The light turns on when the door (LH) is opened. It turns off when the door (LH) is closed.

[ON]

The light remains on regardless of the door position.

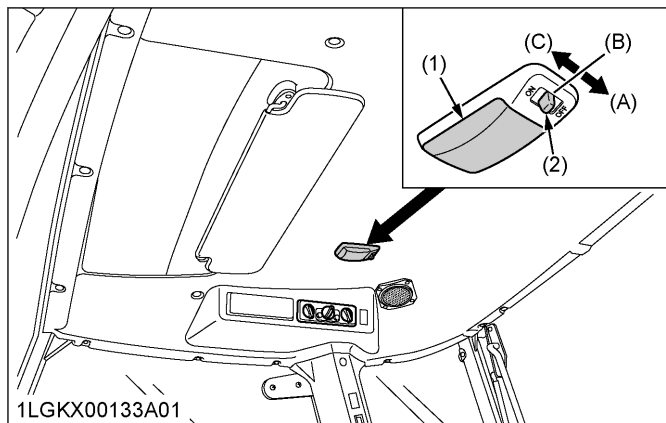

- (1) Dome light
- (2) Dome light switch
- (A) [OFF]
- (B) “DOOR”
- (C) [ON]

IMPORTANT :

- The battery will discharge if the dome light remains on. Be sure to check the dome light switch position and/or door closure.

WORK LIGHT

! WARNING

To avoid personal injury or death:

- Do not operate on roads with work lights on. Work lights may blind or confuse the drivers of oncoming vehicles.

1. Work light switch

Turn on the key switch and press the bottom half of the work light switch. The work light and the switch's indicator light up. Press the top half of the work light switch to turn off the light and indicator.

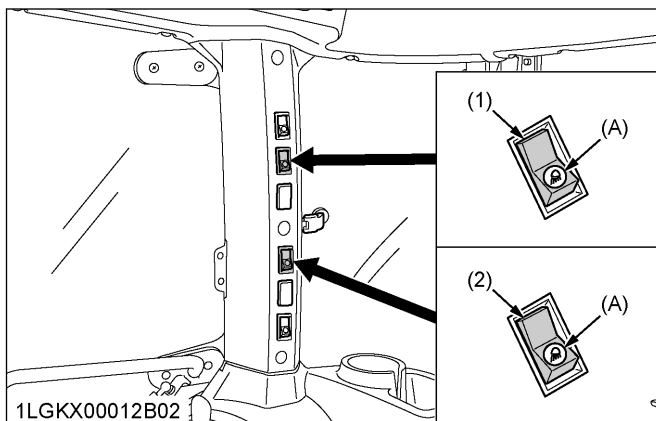

- (1) Front work light switch
- (2) Rear work light switch
- (A) Indicator for work lights

2. Front work light

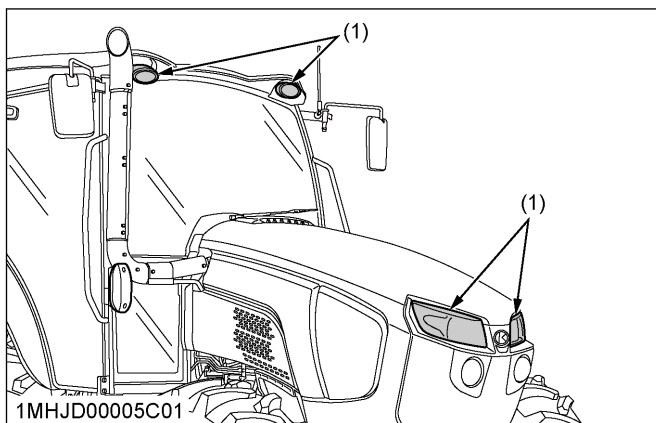

- (1) Front work light

3. Rear work light

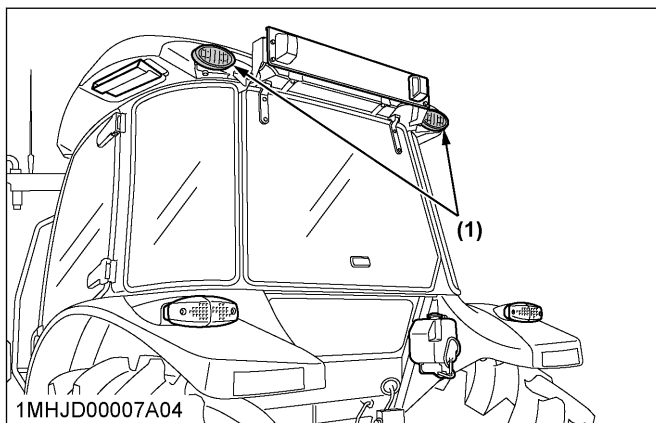

- (1) Rear work light

WIPER

1. Front wiper and washer switch

1. Turn on the key switch and press the bottom half of the wiper switch to the first step to activate the continuous wiper.
When the switch is pressed further to the second step, washer liquid jets out.
The jetting continues while the switch is pressed and the continuous wiper is activated.
2. Press the top half of the wiper switch to the first step to activate the intermittent wiper.
When the switch is pressed further to the second step, washer liquid jets out and the intermittent wiper is activated.

2. Rear wiper and washer switch

1. Turn on the key switch and press the top half of the wiper switch to the first step to activate the wiper.
When the switch is pressed further to the second step, washer liquid jets out.
The jetting continues while the switch is pressed and the wiper is activated continuously.
2. Press the bottom half of the wiper and washer switch, washer liquid only jets out.

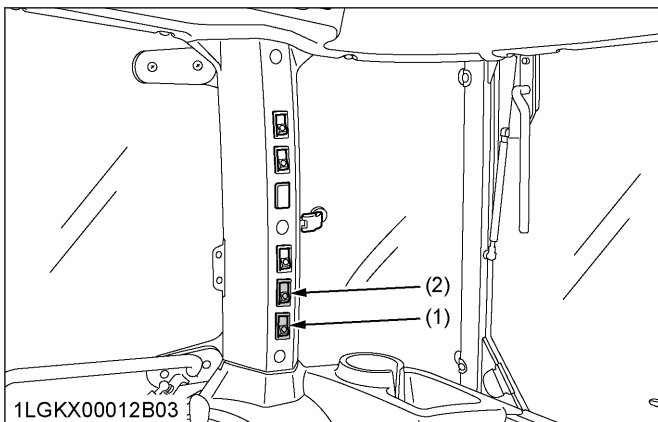

(1) Front wiper and washer switch
(2) Rear wiper and washer switch

IMPORTANT :

- Do not activate the wipers when the windows are dry, as they may be scratched. Be sure to jet washer liquid first and then activate the wipers.

3. Using the wipers in cold season

1. While not used in cold season, keep the wiper blades off the windshield to prevent them from being frozen to the windshield.
2. If the windshield is covered with snow, scrape it off the windshield before using the wipers.

3. If the wiper blades are frozen to the windshield and fail to move, be sure to turn the main key switch to "OFF" and remove the ice from the blades. Then place the main key switch back to "ON".
4. When commercially available cold-season wiper blades are used, make sure their size is the same as or smaller than that of the standard ones.

IMPORTANT :

- In the cold season, the wiper blades and the wiper motor may become overloaded, and cause damage. To avoid this, be sure to take the above precautions.

AIR CONDITIONER

1. Airflow

Air in the CAB and fresh air introduced into the CAB flows as follows. Adjust the air ports to obtain the desired condition.

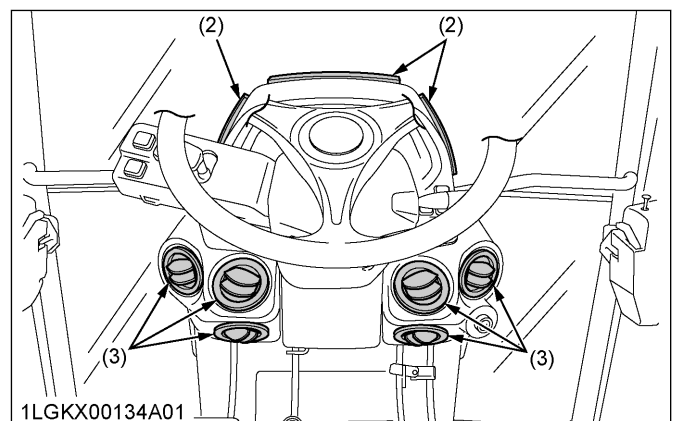
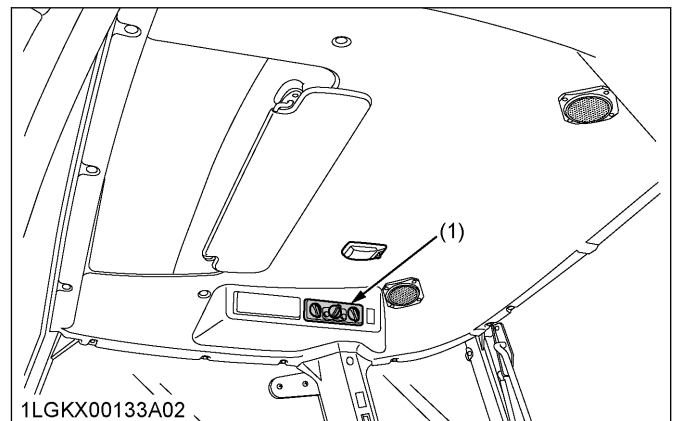

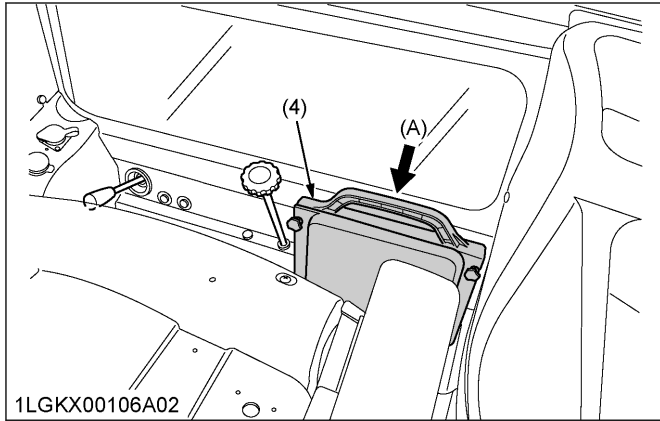

1LGKX00106A02
 (1) Control panel
 (2) Defroster air outlets
 (3) Dashboard air outlets
 (4) Inner air filter
 (A) "INNER AIR RECIRCULATION"

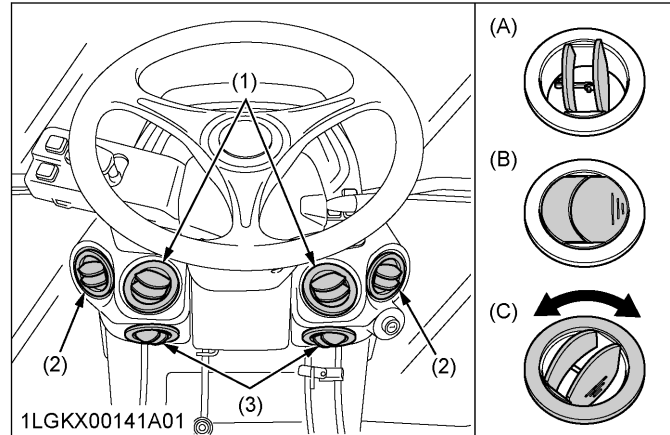

1LGKX00141A01
 (1) Face area air outlets
 (2) Back area air outlets
 (3) Feet area air outlets
 (A) "OPEN"
 (B) "SHUT"
 (C) "TURN"

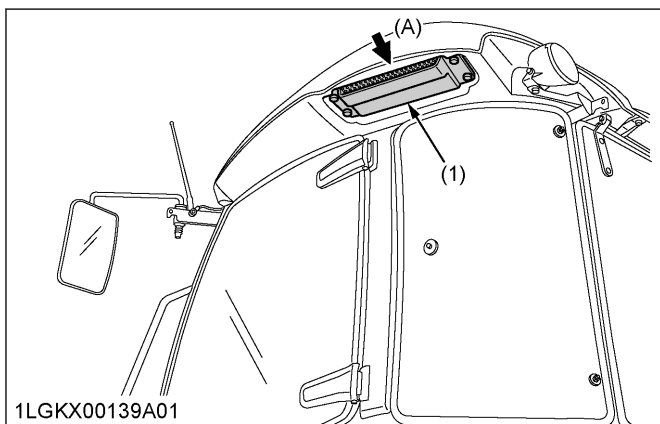

1LGKX00139A01
 (1) Fresh air filter
 (A) "FRESH AIR INLET"

IMPORTANT :

- Do not pour water directly into the fresh air port while washing the tractor.

2. Air control vent

Dashboard air outlet

The dashboard air outlets can be independently adjusted as required.

CAUTION

To avoid personal injury:

- If the window fails to defrost in extreme conditions or becomes cloudy when dehumidifying the CAB, wipe off moisture with a soft cloth.
- Do not block all the air outlets of the air conditioner. A problem could occur.

3. Control panel

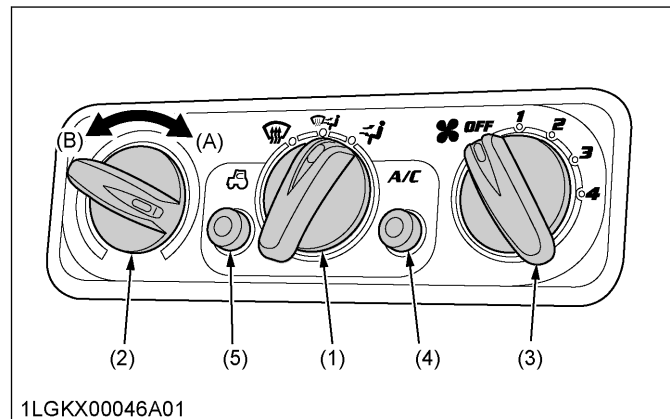

1LGKX00046A01
 (1) Mode switch
 (2) Temperature control dial
 (3) Blower switch
 (4) Air conditioner switch with indicator light
 (5) Recirculation or fresh air selection switch with indicator light
 (A) "WARM"
 (B) "COOL"

3.1 Mode switch

Set the mode switch to the desired position.

- Air is blown from only the dashboard air outlets.
- Air is blown from the dashboard and defroster air outlets.
- Air is blown from only the defroster air outlet.

3.2 Temperature control dial

Set this dial at the desired position to obtain the optimum air temperature. Turn the dial in the "WARM" direction to obtain warmer air. Turn it in the "COOL" direction to obtain cooler air.

3.3 Blower switch

Air volume can be changed in 4 steps. At the [4] position, the largest air volume is obtained.

3.4 Air conditioner switch

Push this switch to activate the air conditioner. An indicator light will light up when the switch is set to "ON".

Push the switch again to turn the air conditioner off, in which case the indicator light will turn off.

3.5 Recirculation or fresh air selection switch

Each time the switch is pressed, the air flow position changes for "RECIRCULATION" or "FRESH AIR". An indicator light will light up when the switch is set to "RECIRCULATION". And the indicator light will be off when the switch is set to "FRESH AIR".

FRESH AIR:

Indicator: "OFF"

Fresh air will flow into the CAB. This is helpful when you work in dusty conditions or if the glass windows get foggy.

RECIRCULATION:

Indicator: "ON"

In-CAB air will be recirculated. This is useful for cooling or heating the CAB quickly or keeping it extra cool or warm.

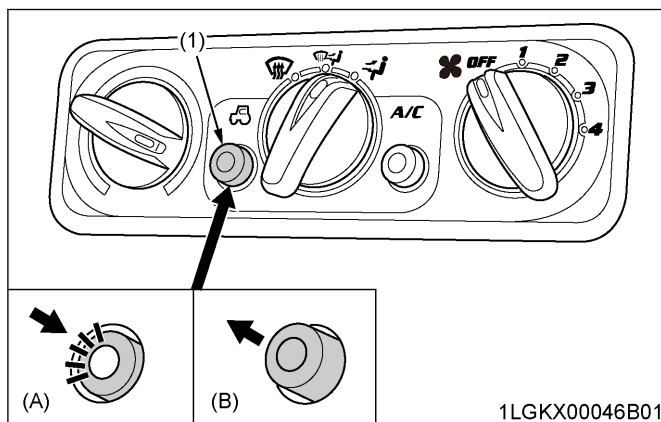

(1) Recirculation or fresh air selection switch with indicator light
 (A) "RECIRCULATION"
 (B) "FRESH AIR"

NOTE :

- When heating, do not keep the switch at the "RECIRCULATION" position for a long time. The windshield easily gets foggy.
- While working in dusty conditions, keep the switch at the "FRESH AIR" position. This increases the pressure in the CAB, which helps prevent dust from coming into the CAB.

4. Operation

4.1 Heating

1. Set the mode switch to the position.
2. Set the recirculation or fresh air selection switch to the "FRESH AIR" position. To raise the temperature in the CAB quickly, set this switch to the "RECIRCULATION" position.
3. Adjust the blower ([1/2/3/4]) switch and the temperature control dial to achieve a comfortable temperature level.

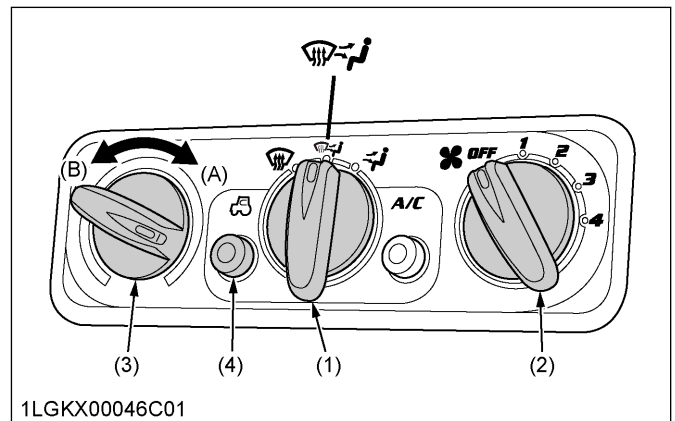

1LGKX00046C01
 (1) Mode switch
 (2) Blower switch
 (3) Temperature control dial
 (4) Recirculation or fresh air selection switch with indicator light
 (A) "WARM"
 (B) "COOL"

- Adjust the air volume and air direction from the dashboard air outlets. In general, open feet area air outlets, and shut face and back area air outlets.

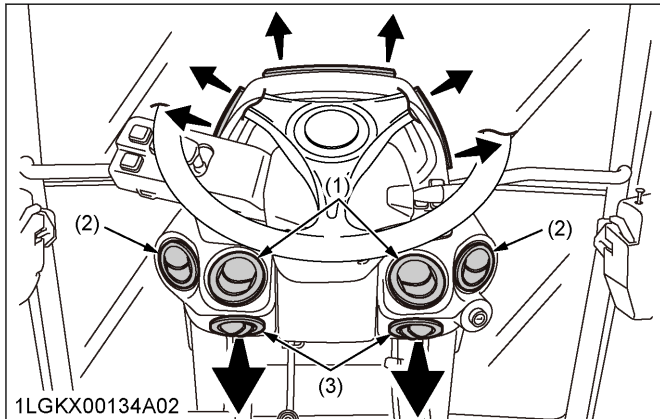

- Face area air outlets
- Back area air outlets
- Feet area air outlets

4.2 Cooling or dehumidifying-heating

- Set the mode switch to the position.
- Set the recirculation or fresh air selection switch to the "FRESH AIR" position. To lower the temperature in the CAB quickly, set this switch to the "RECIRCULATION" position.
- Press and turn on the air conditioner switch with indicator.
- Turn on the blower ([1/2/3/4]) switch.
- Adjust the temperature control dial to "COOL" or intermediate position to achieve a comfortable temperature level.

NOTE :

- In summer when the heater is not used, keep the temperature control dial at the max "COOL" (end of counterclockwise) position. Otherwise, hot air will raise the temperature in the CAB.

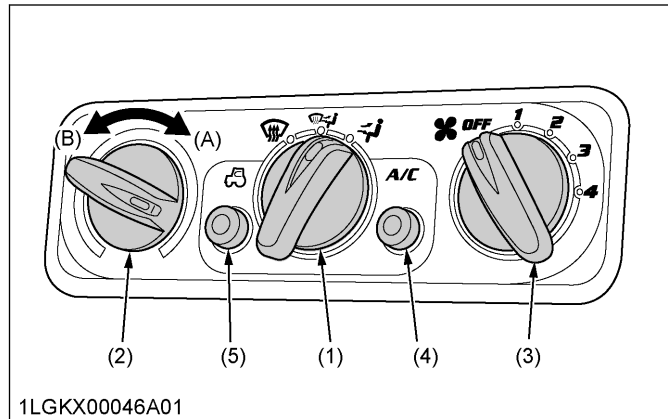

- Mode switch
 - Temperature control dial
 - Blower switch
 - Air conditioner switch with indicator light
 - Recirculation or fresh air selection switch with indicator light
- (A) "WARM"
(B) "COOL"

- Adjust the air volume and air direction from the dashboard air outlets. In general, the air volume from face area air outlets is adjusted to increase, and the air volume from feet and back area air outlets is adjusted to decrease.

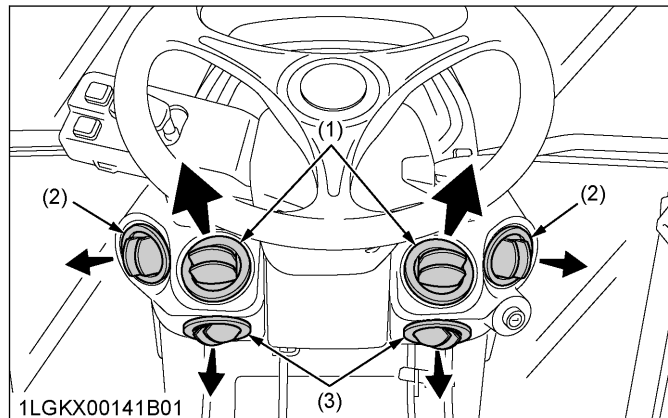

- Face area air outlets
- Back area air outlets
- Feet area air outlets

4.3 Defrosting or demisting

To defrost or demist the windshield, take the following steps.

- Set the mode switch to the position.
- Set the recirculation or fresh air selection switch to the "FRESH AIR" position.

- Set the blower switch and the temperature control dial to the [4] and max "WARM" (end of clockwise) positions, respectively.

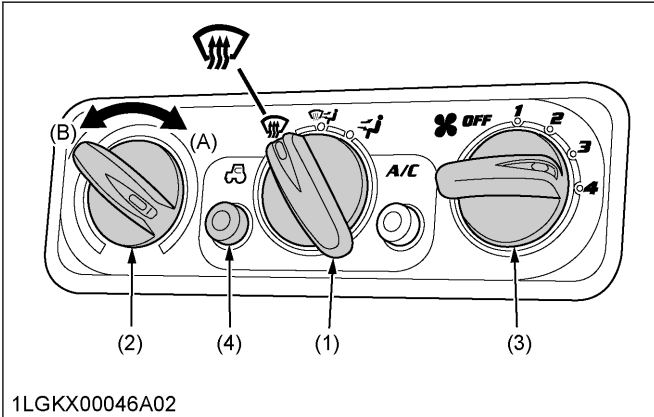

- | | |
|--|------------|
| (1) Mode switch | (A) "WARM" |
| (2) Temperature control dial | (B) "COOL" |
| (3) Blower switch | |
| (4) Recirculation or fresh air selection switch with indicator light | |

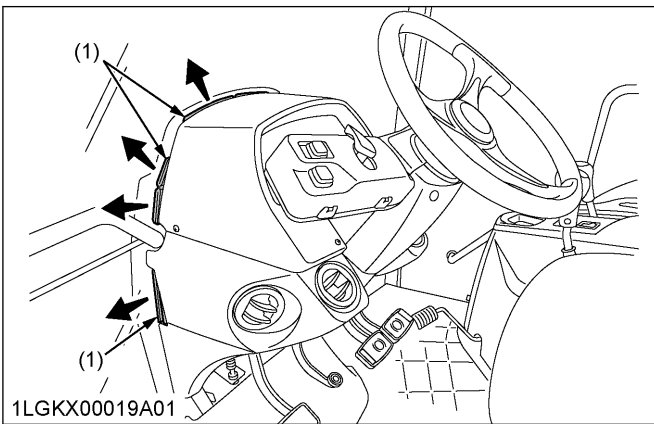

- (1) Defroster air outlet

NOTE :

- If you set the mode switch to position, air will not come out from the dashboard air outlets.

INSTALLING THE IMPLEMENT CONTROL BOX

- Make an opening in each rubber cap or corner plug. Introduce the implement control cable and hydraulic hose through these openings into the CAB.

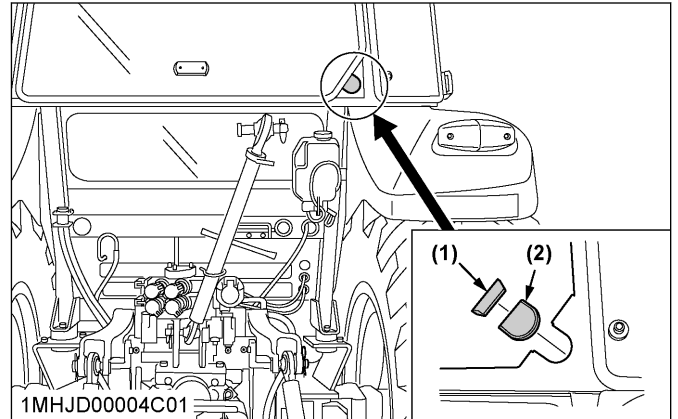

- (1) Rubber cap
(2) Corner cover

ELECTRICAL OUTLET

The tractor is equipped with electrical outlets which serve the following functions.

For use with implement

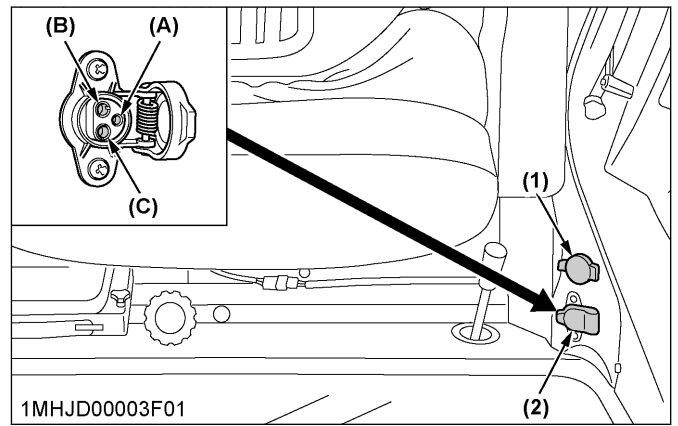

- (1) Accessory electrical outlet (max 10 A)
(2) Accessory electrical outlet
(A) Terminal: through the ACC position of the key switch (max 5 A)
(B) Terminal: through the battery direct (max 25 A)
(C) Terminal: ground

BEACON LIGHT

- The beacon light switch with wire harness for beacon light connection is equipped.
- Turn on the key switch and press the bottom half of the beacon light switch. Then the beacon light and indicator of switch will be activated.
- Press the top half of the switch, and turn off the light and the indicator.

CAB OPERATION

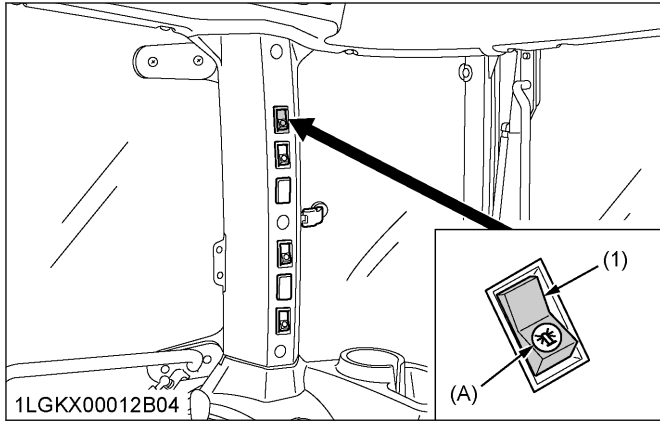

(1) Beacon light switch

(A) Indicator for beacon light

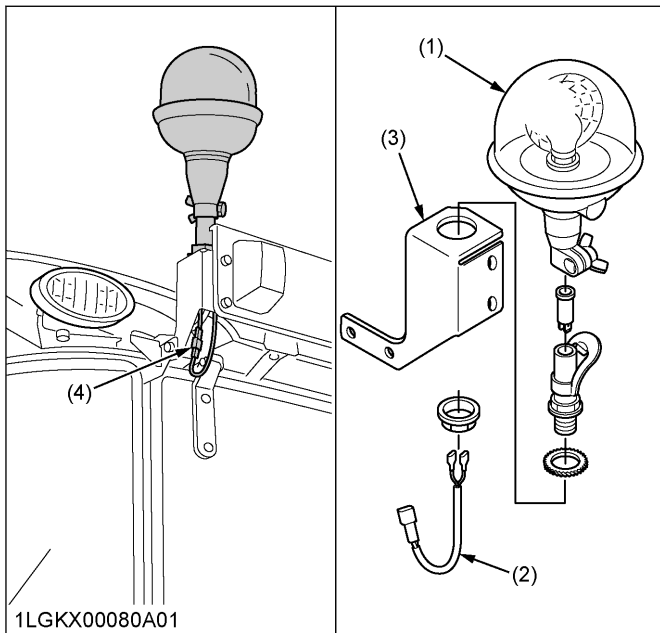

(1) Beacon light (if equipped)

(2) Relay harness for beacon light (max 7 A)

(3) Stay

(4) Beacon electrical outlet

NOTE :

- The relay harness for beacon light is in the accessories box.
- Pre-assemble the beacon light and relay harness, and connect the relay harness to the connector of beacon electrical outlet.

MAINTENANCE

SERVICE INTERVALS

	Interval	Items	Ref. page		
A	initial 50 Hr	Engine oil	Change	116	
		Engine oil filter	Re-place	116	
B	every 50 Hr	Engine start system	Check	116	*1
		Wheel bolt torque	Check	117	
		Tie-rod dust cover	Check	117	*1
C	every 100 Hr	Greasing	---	117	
		Air cleaner primary element	Clean	119	*2
		Fan belt	Adjust	119	
		Brake pedal	Adjust	120	*1
		Gear-locked parking brake	Check	120	*1
		Parking brake	Adjust	121	
		Battery condition	Check	121	*3
		Air conditioner drive belt	Adjust	122	
D	every 200 Hr	Toe-in	Adjust	123	
		Fuel tank water	Drain	123	
		Inner air filter	Clean	123	
		Fresh air filter	Clean	124	*4
E	every 400 Hr	Water separator	Clean	124	
F	every 500 Hr	Engine oil	Change	125	*5
		Engine oil filter	Re-place	125	*5
		Fuel filter	Re-place	126	
		Hydraulic oil filter	Re-place	126	
		Power steering oil line	Check	127	*6
		Radiator hose and clamp	Check	127	*6
		Fuel line	Check	128	*6
		Intake air line	Check	128	*6
		Lift cylinder hose	Check	129	*6
Air conditioner pipes and hoses	Check	130	*6		

(Continued)

	Interval	Items	Ref. page		
G	every 600 Hr	Front axle pivot	Adjust	130	
H	every 1000Hr	Transmission fluid	Change	130	
		Front differential case oil	Change	130	
		Front axle gear case oil	Change	131	
		Engine valve clearance	Adjust	131	*1
I	every 1000Hr or 1 year*7	Air cleaner primary element	Re-place	131	
		Air cleaner secondary element	Re-place	131	
		Exhaust manifold	Check	131	*1
		Fresh air filter	Re-place	-	*1
		Fuel injector nozzle tip	Check	131	*1
J	every 1500Hr	EGR cooler	Check Clean	131	*1
		Cooling system	Flush	131	
K	every 2000Hr or 2 years*8	Coolant	Change	132	
		Turbocharger	Check	133	*1
L	every 3000Hr	Supply pump	Check	133	*1
		Intake air heater	Check	133	*1
		EGR system	Check Clean	133	*1
		DPF muffler	Clean	133	*1
		CAB isolation cushion	Check	133	
M	every 1 year	DPF related pipe	Check	133	*1
		EGR pipe	Check	134	*1
		Breather related rubber pipe	Re-place	134	*1
N	every 2 years	Boost sensor hose	Re-place	134	*1
		DPF related rubber pipe	Re-place	134	*1
		EGR cooler hose	Re-place	134	*1
		Master cylinder filter	Clean	134	*1
		Cables of both parking brakes	Re-place	134	*1
		O	every 3 years		

(Continued)

	Interval	Items	Ref. page		
P	every 4 years	Radiator hose and clamp	Re-place	134	
		Fuel line	Re-place	134	*1
		Intake air line	Re-place	134	*1
		Power steering oil line	Re-place	134	*1
		Lift cylinder hose	Re-place	134	*1
		Master cylinder kit	Re-place	134	*1
		Brake seal 1 and 2	Re-place	134	*1
		Air conditioner pipes and hoses	Re-place	134	*1
Q	Service as required	Fuel system	Bleed	134	
		Brake system	Bleed	135	*1
		Clutch housing water	Drain	135	
		Fuse	Re-place	135	
		Light bulb	Re-place	138	
		Head lamp	Re-place	138	
		Lubricating point for door and window	---	138	
		Washer liquid	Add	138	
		Refrigerant (gas)	Check	138	

2. Details regarding maintenance items can be found in a different section.
(See SERVICE INTERVALS on page 105.)

- *1 Consult your local KUBOTA Dealer for this service.
- *2 Air cleaner should be cleaned more often in dusty conditions than in normal conditions.
- *3 When the battery is used for less than 100 hours per year, check the battery condition by reading the indicator annually.
- *4 Clean and replace the fresh air filter more frequently if used under dusty conditions. When the filter is very dirty from dusty conditions, replace the filter.
- *5 The initial 50 hours should not be a replacement cycle.
- *6 Replace if any deterioration (crack, hardening, scar, or deformation) or damage occurred.
- *7 Every 1000 hours or every 1 year, whichever comes first.
- *8 Every 2000 hours or every 2 years, whichever comes first.

MAINTENANCE ITEMS CHART

How to use the chart

1. The circles in this at-a-glance chart indicate the relevant points between the tractor's hour meter readings and the service intervals. Following these circles and the maintenance item group (A thru P), keep up your tractor.

Chart at a glance

Hour meter	Maintenance items															
	A	B	C	D	E	F	G	H	I	J	K	L	M	N	O	P
50	o	o														
100		o	o													
150		o														
200		o	o	o												
250		o														
300		o	o													
350		o														
400		o	o	o	o											
450		o														
500		o	o			o										
550		o														
600		o	o	o			o									
650		o														
700		o	o													
750		o														
800		o	o	o	o											
850		o														
900		o	o													
950		o														
1000		o	o	o		o		o								
1050		o														
1100		o	o													
1150		o														
1200		o	o	o	o		o									
1250		o														
1300		o	o													
1350		o														
1400		o	o	o											o	
1450		o														
1500		o	o			o				o						o
1550		o														
1600		o	o	o	o											
1650		o														
1700		o	o													
1750		o														
1800		o	o	o			o									
1850		o														
1900		o	o													

(Continued)

Hour meter	Maintenance items															
	A	B	C	D	E	F	G	H	I	J	K	L	M	N	O	P
1950		o														
2000		o	o	o	o	o		o								
2050		o														
2100		o	o													
2150		o														
2200		o	o	o												
2250		o														
2300		o	o													
2350		o														
2400		o	o	o	o			o								
2450		o														
2500		o	o			o										
2550		o														
2600		o	o	o												
2650		o														
2700		o	o													
2750		o														
2800		o	o	o	o											
2850		o														
2900		o	o													
2950		o														
3000		o	o	o		o	o	o		o		o				
Every 1000 Hr or 1 year										o						
Every 2000 Hr or 2 years												o				
Every 1 year													o			
Every 2 years														o		
Every 3 years															o	
Every 4 years																o

LUBRICANTS, FUEL AND COOLANT

No.	Locations	Capacities		Lubricants	
		M5091	M5111		
1	Fuel	105 L		No.2-D S15 diesel fuel No.1-D S15 diesel fuel if temperature is below -10 °C	
2	Coolant	10 L (Recovery tank: 1.0 L)		Fresh clean soft water with antifreeze	
3	Washer liquid	1.3 L		Automobile washer liquid	
4	Engine crankcase (with filter)	10.7 L		• Engine oil: API service classification	CJ-4 (DPF type engine)
				Above 25 °C	SAE30, SAE10W-30 or 15W-40
				-10 °C to 25 °C	SAE10W-30 or 15W-40
				Below -10 °C	SAE10W-30
5	Transmission case	60 L		• KUBOTA UDT or SUPER UDT fluid*	
6	Front differential case oil (4WD)	6.0 L		• KUBOTA UDT or SUPER UDT fluid* or SAE 80 - SAE 90 gear oil	
7	Front axle gear case oil (4WD)	3.5 L			
8	Greasing	No. of greasing points		Capacity	Type of grease
	Top link	2		Until grease overflows.	Multipurpose grease NLGI-2 or NLGI-1 (GC-LB)
	Top link bracket	2			
	Lift rod	2			
	Hydraulic lift cylinder pin	4			
	Front axle gear case support	2			
	Front axle support	2			
	Steering joint shaft	1			
	Battery terminal	2		A small amount	

NOTE :

- The product name of Kubota genuine UDT fluid may be different from that in the operator's manual depending on countries or territories. Consult your local KUBOTA Dealer for further details.

Engine oil

- The oil used in the engine should have an American Petroleum Institute (API) service classification and proper SAE engine oil according to the ambient temperatures shown in the previous table.
- Refer to the following table for the suitable API classification engine oil according to the diesel particulate filter (DPF) type engines and the fuel.

Fuel used	Engine oil classification (API classification)
	Oil class for engines with DPF
Ultra low sulfur fuel <0.0015% (15 ppm)	CJ-4

Fuel

- Use the ultra low sulfur diesel fuel only (below 0.0015% or 15 ppm) for these engines.
- Cetane number of 45 minimum. Cetane number greater than 50 is preferred, especially for temperatures below -20 °C or elevations above 1500 m.
- Diesel fuels specified to EN 590 or ASTM D975 are recommended.

- No.2-D is a distillate fuel of lower volatility for engines in industrial and heavy mobile service (SAE J313 JUN87).

Transmission oil

The oil used to lubricate the transmission is also used as hydraulic fluid. To ensure proper operation of the hydraulic system and to complete lubrication of the transmission, it is important that a multi-grade transmission fluid is used in this system. We recommend the use of **KUBOTA UDT** or **SUPER UDT** fluid for optimum protection and performance. Consult your local KUBOTA Dealer for further detail.

Do not mix different brands together.

Indicated capacities of water and oil are manufacturer's estimate.

PERIODIC SERVICE

WARNING

To avoid personal injury or death:

- Do not work under any hydraulically supported devices. They can settle, suddenly leak, or be accidentally lowered. If necessary to work under the tractor or any machine elements for servicing or adjustments, securely support them with stands or suitable blocking beforehand.

WASTE DISPOSAL

- The improper disposal or burning of waste causes environmental pollution and can be punishable by your local laws and regulations.
 - When draining fluids from the tractor, place a container underneath the drain port.
 - Do not pour waste onto the ground, down a drain, or into any water source (such as rivers, streams, lakes, marshes, seas and oceans).
 - Waste products such as used oil, fuel, coolant, hydraulic fluid, urea aqueous solution (DEF/ AdBlue®), refrigerant, solvent, filters, rubber, batteries and harmful substances, can harm the environment, people, pets and wildlife. Please dispose properly. See your local recycling center or KUBOTA Dealer to learn how to recycle or get rid of waste products.

HOW TO OPEN THE HOOD

WARNING

To avoid personal injury or death from contact with moving parts:

- Never open the hood while the engine is running.
- Do not touch the muffler or exhaust pipes while they are hot; severe burns could result.
- Hold the hood with the other hand while unlocking the release lever.

1. Hood

1. To open the hood, hold the hood, pull the release lever and then open the hood.

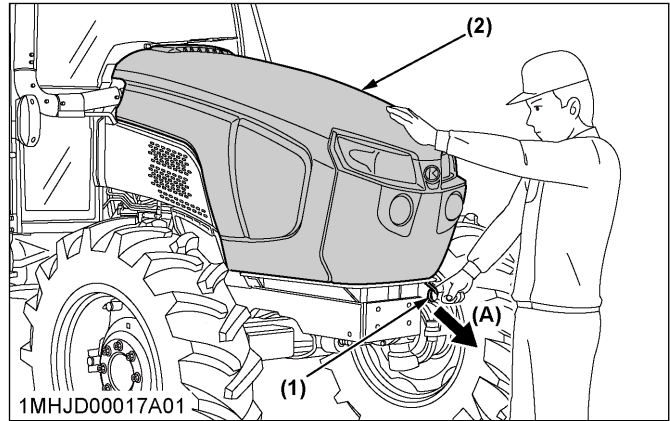

(1) Tool
(2) Hood

(A) "PULL"

NOTE :

- To close the hood, push the hood into position using both hands.

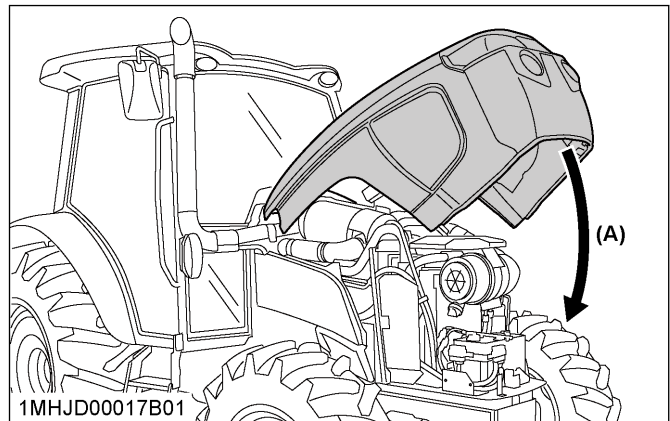

(A) "Push down using both hands to close the hood"

2. Side cover

1. Remove the bolts (2). Move the side cover 1 forward, and pull out the cover from pins.

2. Loosen the bolts (5), and remove the side cover 2.

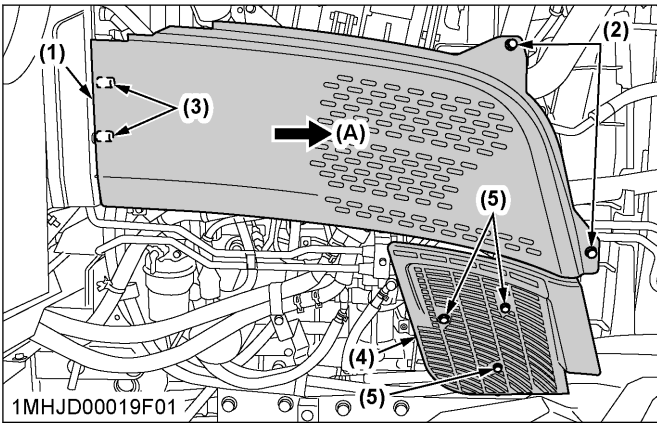

- (1) Side cover 1
- (2) Bolt
- (3) Pin
- (4) Side cover 2
- (5) Bolt
- (A) "MOVE"

DAILY CHECK

For your own safety and maximum service life of the machine, make a thorough daily inspection before operating the machine to start the engine.

WARNING

To avoid personal injury or death:
Take the following precautions when checking the tractor.

- Park the machine on firm and level ground.
- Set both parking brakes.
- Lower the implement to the ground.
- Release all residual pressure from the hydraulic system.
- Stop the engine and remove the key.

1. Walk around inspection

Look around and under the tractor for items such as loose bolts, trash build-up, oil or coolant leaks, broken or worn parts.

2. Checking and refueling

WARNING

To avoid personal injury or death:

- Never use fire.
- Do not smoke while refueling.
- Be sure to stop the engine and remove the key before refueling.
- Use properly grounded fueling systems. Make sure that there is no static discharge while refueling.

- Be sure to close the fuel tank cap after refueling.

To avoid allergic skin reaction:

- Wash hands immediately after contact with diesel fuel.

1. Check the amount of fuel by looking at the fuel gauge.
2. When the fuel warning indicator lights up, it is time to add fuel.

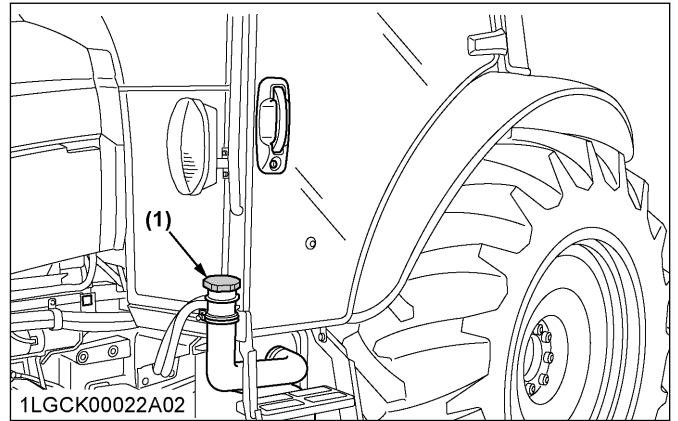

(1) Fuel tank cap

Fuel tank capacity	105 L
--------------------	-------

IMPORTANT :

- Be sure to use ultra-low sulfur fuel (S15).
- Do not permit dirt or trash to get into the fuel system.
- Be careful not to let the fuel tank become empty. Otherwise, air will enter the fuel system, necessitating bleeding before the next engine start.
- If the engine runs out of fuel and stalls, engine components may become damaged.
- Be careful not to spill during refueling. If a spill occurs wipe it off at once or it may cause a fire.
- To prevent condensation (water) accumulation in the fuel tank, fill the tank before parking overnight.

3. Checking water separator

1. When the water has collected up to the upper limit in the water separator, the water separator indicator on the instrument panel lights up and a warning buzzer sounds.

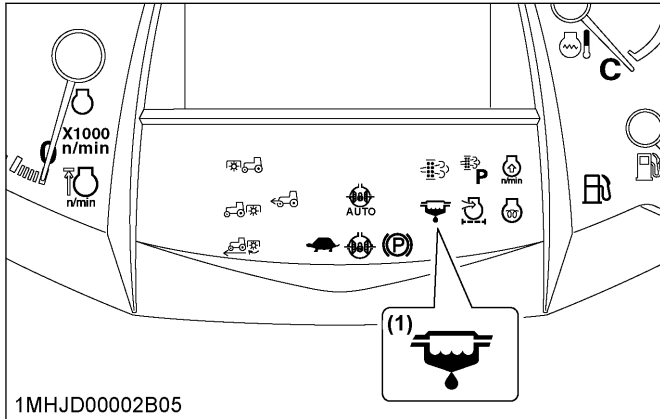

(1) Water separator indicator

2. In this case, close the fuel shutoff-valve and loosen the air plug and drain plug by several turns.
3. Allow the water to drain. When no more water comes out and fuel starts to flow out, retighten the air plug and drain plug.
4. Bleed the fuel system.
(See SERVICE AS REQUIRED on page 134.)

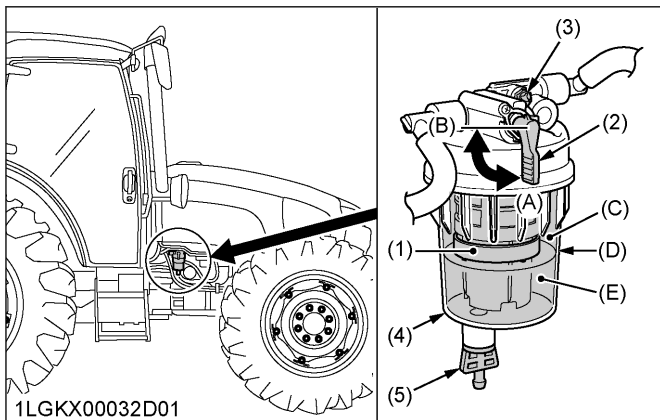

- | | |
|------------------------|-------------------|
| (1) Red float | (A) [ON] |
| (2) Fuel shutoff-valve | (B) [OFF] |
| (3) Air plug | (C) "FUEL" |
| (4) Cup | (D) "UPPER LIMIT" |
| (5) Drain plug | (E) "WATER" |

IMPORTANT :

- If water is drawn through to the fuel pump, extensive damage will occur.

NOTE :

- When the red float reaches near the upper limit level, start from step 2 in the above procedure to drain water from the water separator.

4. Checking engine oil level

WARNING

To avoid personal injury or death:

- Be sure to stop the engine before checking the oil level.

1. Park the machine on a flat surface.
2. Check engine oil before starting the engine or 5 minutes or more after the engine has stopped.
3. To check the oil level, draw out the dipstick, wipe it clean, replace it, and draw it out again. Check to see that the oil level lies between the 2 notches. If the level is too low, add new oil to the prescribed level at the oil inlet.
(See LUBRICANTS, FUEL AND COOLANT on page 108.)

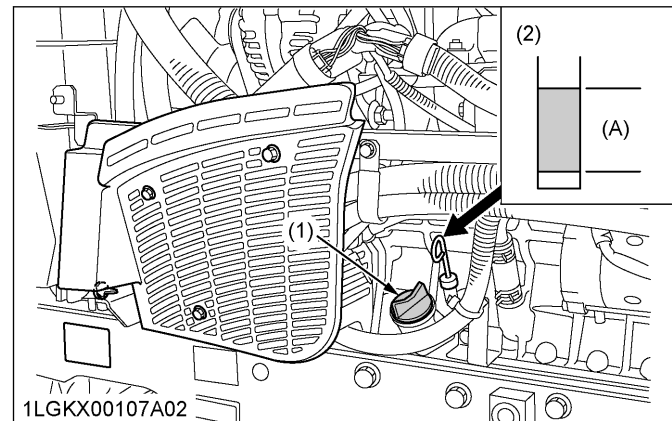

- (1) Oil inlet
(2) Dipstick

(A) Oil level is acceptable within this range.

IMPORTANT :

- When using an oil of different manufacturer or viscosity from the previous one, remove all of the old oil.
Never mix 2 different types of oil.
- If the oil level is low, do not run the engine.

NOTE :

- At times, a small amount of fuel, which is used to regenerate the DPF, may get mixed with the engine oil and the engine oil may increase in volume.

5. Checking transmission fluid level

1. Park the machine on a flat surface, lower the implement and shut off the engine.

- To check the oil level, draw out the dipstick, wipe it clean, replace it, and draw it out again. Check to see that the oil level lies between the 2 notches. If the level is too low, add new oil to the prescribed level at the oil inlet. (See LUBRICANTS, FUEL AND COOLANT on page 108.)

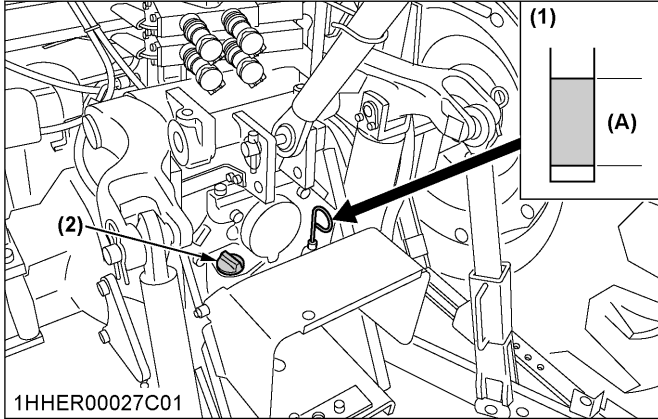

(1) Dipstick (A) Oil level is acceptable within this range.
 (2) Oil inlet

IMPORTANT :

- If the oil level is low, do not run the engine.

6. Checking coolant level

⚠ WARNING

To avoid personal injury or death:

- Do not remove the radiator cap while the coolant is hot. When cool, slowly rotate the cap to the first stop and allow sufficient time for excess pressure to escape before removing the cap completely.

- Check to see that the coolant level is between the [FULL] and [LOW] marks of the recovery tank.
- When the coolant level drops due to evaporation, add soft water only up to the full level. In case of leakage, add antifreeze and soft water in the specified mixing ratio up to the full level. (See Flushing cooling system and changing coolant on page 131.)
- When the coolant level is lower than the [LOW] mark of the recovery tank, remove the radiator cap and check to see that the coolant level is just below the port. If the level is low, add coolant.

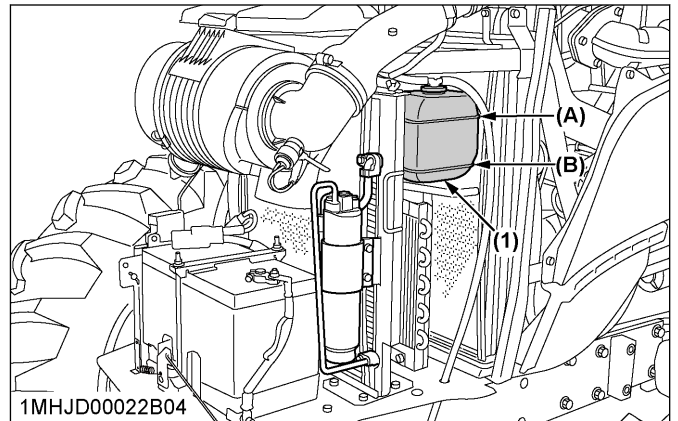

(1) Recovery tank (A) [FULL] (B) [LOW]

IMPORTANT :

- If the radiator cap has to be removed, follow the caution above and securely retighten the cap.
- Use clean, fresh soft water and antifreeze to fill the radiator.
- If coolant should leak, consult your local KUBOTA Dealer.

7. Cleaning evacuator valve

Open the evacuator valve to get rid of large particles of dust and dirt.

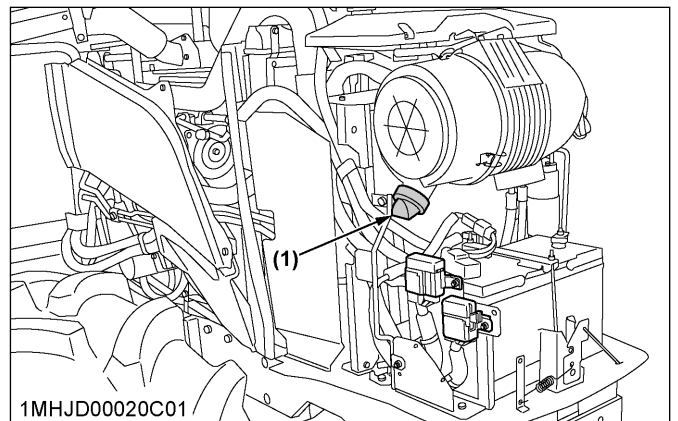

(1) Evacuator valve

8. Cleaning grill, radiator screen, oil cooler, fuel cooler, air conditioner condenser and battery mount

⚠ WARNING

To avoid personal injury or death:

- Be sure to stop the engine before removing the screen.
- The condenser and receiver become hot while the air conditioner is running. Before checking

or cleaning them, wait until they cool down enough.

8.1 Detaching the panel

1. Pull the upper part of the panel outward.
2. Raise the panel until pin (A) clears the hole, and take out the panel.

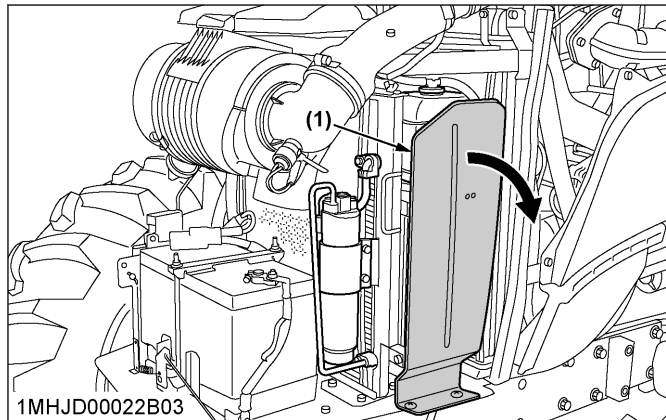

(1) Panel

3. Attaching the panel is performed vice versa.

8.2 Sliding the air conditioner condenser

1. Loosen the wing nut.
2. Hold the handle, slide the air conditioner condenser assembly toward yourself.

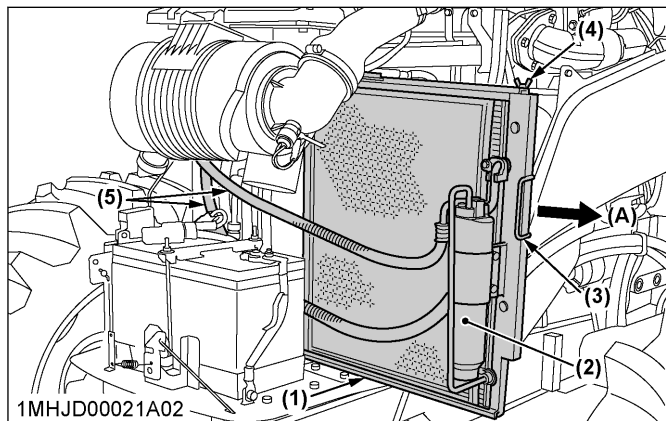

(1) Condenser
 (2) Receiver
 (3) Handle
 (4) Wing nut
 (5) Air conditioner hose

IMPORTANT :

- Do not hold the air conditioner receiver or the air conditioner pipes when sliding out the condenser for cleaning.

8.3 Cleaning

1. Check the front grill to make sure it is clean from debris.
2. Detach the radiator and air conditioner screens and remove all foreign materials.
3. Check radiator, intercooler, oil cooler, fuel cooler, air conditioner condenser and battery mount to be sure they are clean from debris.

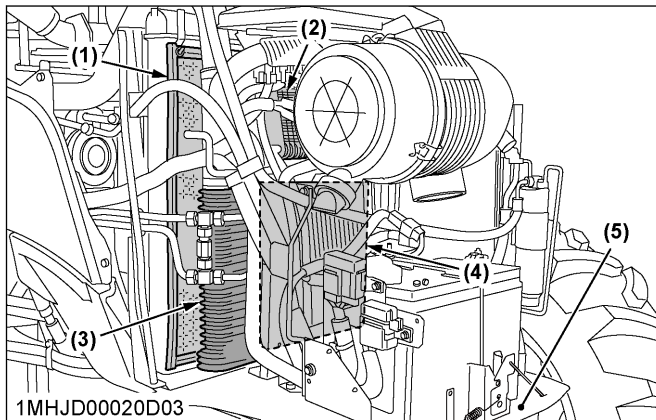

(1) Radiator screen
 (2) Fuel cooler
 (3) Intercooler (if equipped)
 (4) Oil cooler
 (5) Battery mount

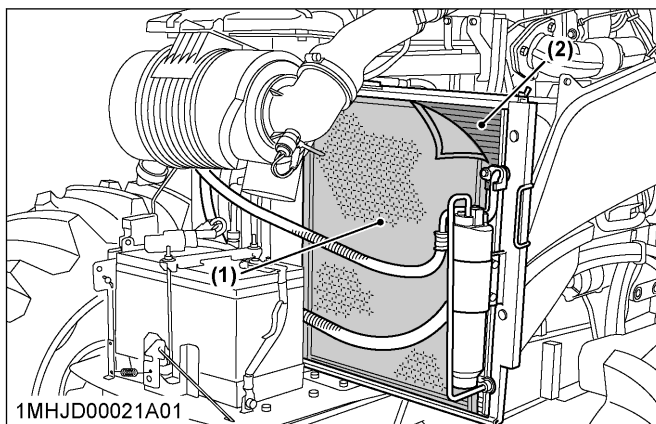

(1) Air conditioner condenser screen
 (2) Air conditioner condenser

9. Checking DPF muffler

WARNING

To avoid personal injury or death:

- Before checking or cleaning the DPF muffler, stop the engine and wait until it is cooled down enough.

1. Check the DPF muffler and its surroundings for build-up of anything flammable. Otherwise a fire may result.

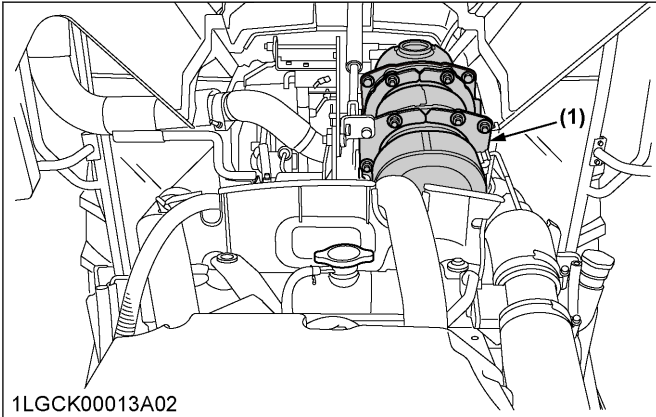

(1) DPF muffler

10. Checking brake pedal

⚠ WARNING
To avoid personal injury or death:

- Make sure that the brake pedals have equal adjustments when being locked together. Incorrect or unequal brake pedal adjustments can cause the tractor to swerve or roll-over.

1. Inspect the brake pedals for free travel and smooth operation.
2. Adjust if incorrect measurement is found. (See Adjusting brake pedal on page 120.)

11. Checking gear-locked parking brake

Pull the gear-locked parking brake lever to apply the brakes. With the key switch at "ON" position, the parking brake indicator on the instrument panel lights up.

To release the brakes, push in the button at the tip of the gear-locked parking brake lever and push the lever forward.

NOTE :

- Make sure the parking brake warning indicator (P) on the instrument panel goes off when the gear-locked parking brake lever is released.

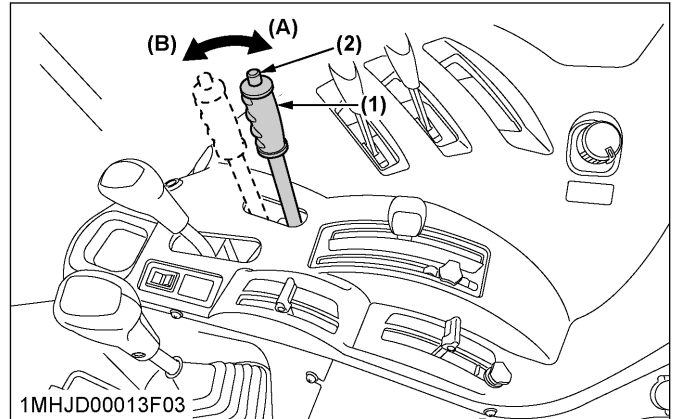

(1) Gear-locked parking brake lever (A) "PARKING POSITION" (B) "TRANSPORT POSITION"
 (2) Release button

12. Checking parking brake

Pull the parking brake lever to apply the brakes. With the key switch at "ON" position, the parking brake indicator on the instrument panel lights up.

To release the brakes, push in the button at the tip of the parking brake lever and tilt down the lever.

NOTE :

- Make sure the parking brake warning indicator (P) on the instrument panel goes off when the parking brake lever is released.

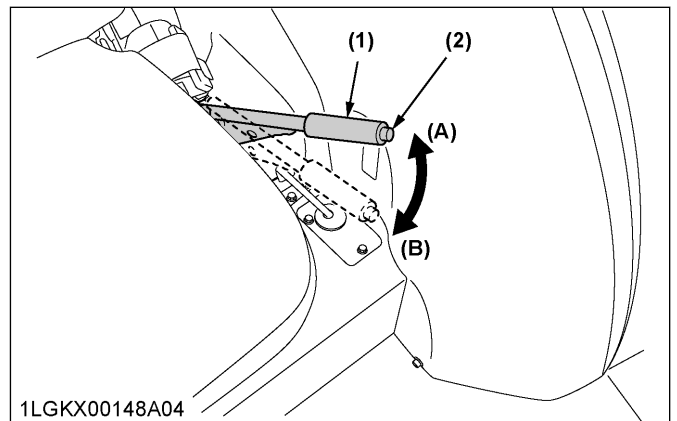

(1) Gear-locked parking brake lever (A) "PARKING POSITION" (B) "TRANSPORT POSITION"
 (2) Release button

13. Checking gauges, meter and Easy Checker™

1. Inspect the instrument panel for broken gauge(s), meter(s) and Easy Checker™ indicators.
2. Replace if broken.

14. Checking headlight, turn signal light, hazard light, and so on

1. Inspect the lights for broken bulbs and lenses.
2. Replace if broken.

15. Checking seat belt

1. Always check the condition of the seat belt attaching hardware before operating the tractor.
2. Replace if damaged.

16. Checking movable parts

If any of the movable parts, such as levers and pedals, are not moving smoothly because of rust or sticky material, do not attempt to force them into motion. In the above case, remove the rust or the sticky material and apply oil or grease to the relevant spot. Otherwise, the machine may be damaged.

INITIAL 50 HOURS

With a new machine, be sure to do the following servicing after the first 50 operating hours.

1. Changing engine oil

(See Changing engine oil on page 125.)

2. Replacing engine oil filter

(See Replacing engine oil filter on page 125.)

EVERY 50 HOURS

1. Checking engine start system

WARNING

To avoid personal injury or death:

- Do not allow anyone near the tractor while testing.
- If the tractor does not pass the test, do not operate the tractor.

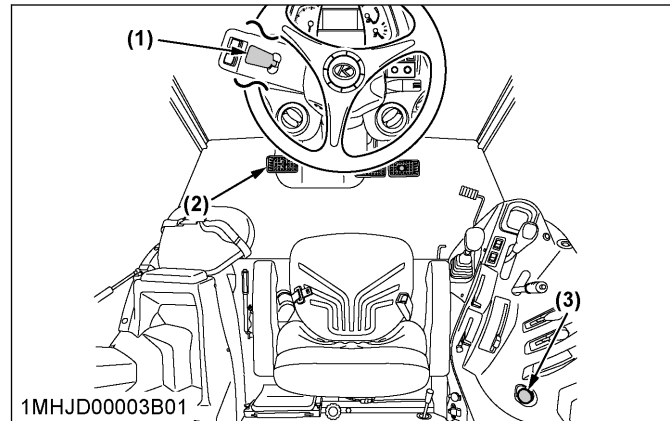

- (1) Shuttle shift lever
- (2) Clutch pedal
- (3) PTO clutch control switch

1.1 Preparation before testing

1. Place all control levers in the "NEUTRAL" position.
2. Set both parking brakes, stop the engine and lower all implements.

1.2 Testing switch for the shuttle shift lever

1. Follow the "PARKING THE TRACTOR" instructions. (See PARKING THE TRACTOR on page 71.)
2. Sit on the operator's seat.
3. Shift the shuttle shift lever to the forward or reverse position.
4. Depress the clutch pedal fully.
5. Disengage the PTO clutch control switch.
6. Turn the key to "START" position.
7. The engine must not crank.
8. If it cranks, consult your local KUBOTA Dealer for this service.

1.3 Testing switch for PTO clutch control switch

1. Follow the "PARKING THE TRACTOR" instructions. (See PARKING THE TRACTOR on page 71.)
2. Sit on the operator's seat.
3. Engage the PTO clutch control switch.
4. Depress the clutch pedal fully.
5. Shift the shuttle shift lever to the "NEUTRAL" position.
6. Turn the key to "START" position.
7. The engine must not crank.
8. If it cranks, consult your local KUBOTA Dealer for this service.

2. Checking operator presence control (OPC) system

WARNING

To avoid personal injury or death:

- Before checking the PTO OPC, make sure that the PTO drive shaft is disconnected from the tractor.
- If the buzzer does not sound during the PTO OPC check procedure, shut off the engine and consult your local KUBOTA Dealer for immediate servicing of the PTO OPC.
- The unit should not be operated until servicing is completed.

1. Follow the "PARKING THE TRACTOR" instructions. (See PARKING THE TRACTOR on page 71.)
2. Make sure the PTO drive shaft is disconnected from the tractor.
3. Sit on the operator's seat.
4. Start the engine.
5. Engage the PTO gear shift lever (if equipped).
6. Engage the PTO clutch control switch. The PTO should begin to rotate. Disengage the PTO clutch control switch.
7. While lifting yourself from the seat, engage the PTO clutch control switch.
 - a. The PTO should begin to rotate and a buzzer should sound.
 - b. Disengage the PTO clutch control switch.
 - c. If the buzzer does not sound, shut off the engine and consult your local KUBOTA Dealer for immediate servicing of the PTO OPC.
8. If the PTO OPC is operating properly, shut off the engine, and reconnect the implement drive shaft to the PTO. Restart the engine per the available instructions.

3. Checking wheel bolt torque

WARNING

To avoid personal injury or death:

- Never operate the tractor with a loose rim, wheel or axle.
- Any time bolts and nuts are loosened, retighten to the specified torque.
- Check all bolts and nuts frequently and keep them tight.

Check wheel bolts and nuts regularly, especially when new. If they are loose, tighten them as follows.

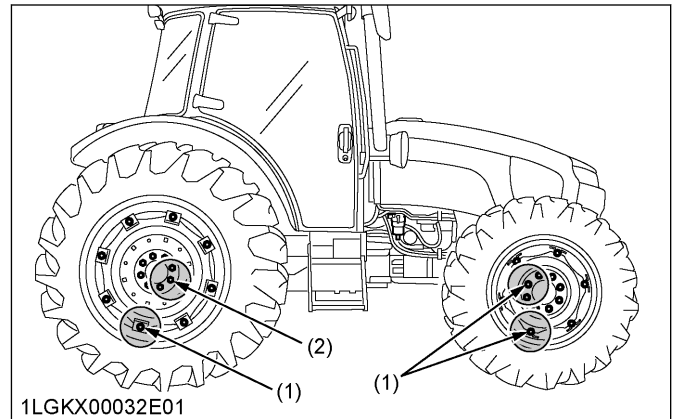

- (1) 260 to 304 N·m / 26.5 to 31.0 kgf·m
 (2) 343 to 401 N·m / 35.0 to 41.0 kgf·m

4. Checking tie-rod dust cover

Check to see that dust covers are not damaged.

If dust covers are damaged, consult your local KUBOTA Dealer for this service.

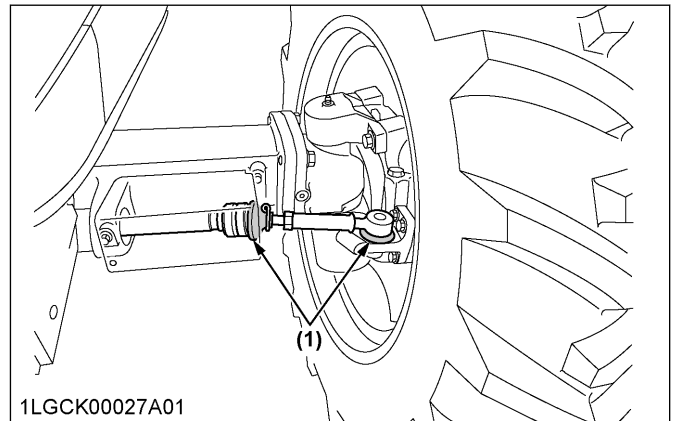

- (1) Dust cover (both sides, RH not shown in illustration)

IMPORTANT :

- If dust covers are cracked, water and dust can cause premature wear of the tie-rod.

EVERY 100 HOURS

1. Lubricating grease fittings

Apply a small amount of multipurpose grease to the following points every 100 hours.

If you have been operating the machine in extremely wet and muddy conditions, lubricate the grease fittings more often.

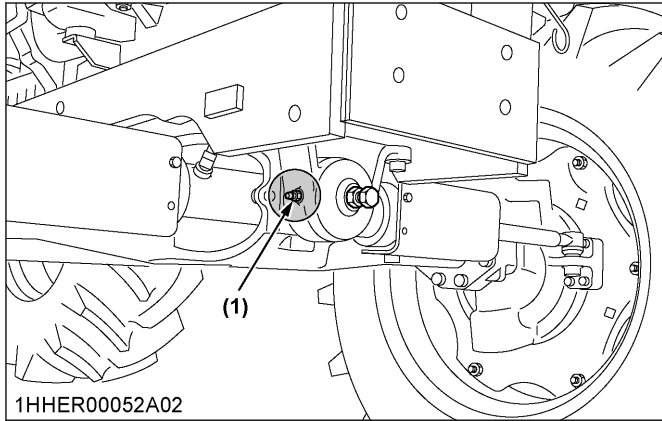

(1) Grease fitting (front axle support)

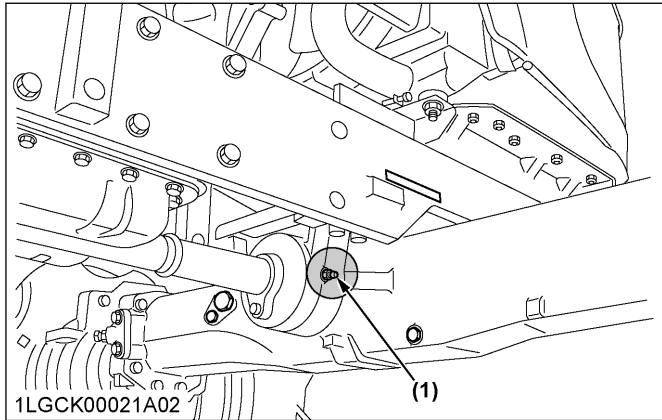

(1) Grease fitting (front axle support)

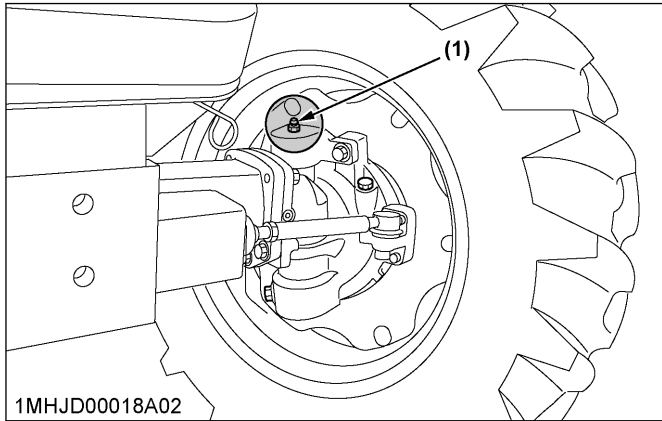

(1) Grease fitting (front axle gear case support) - both sides, RH not shown in illustration

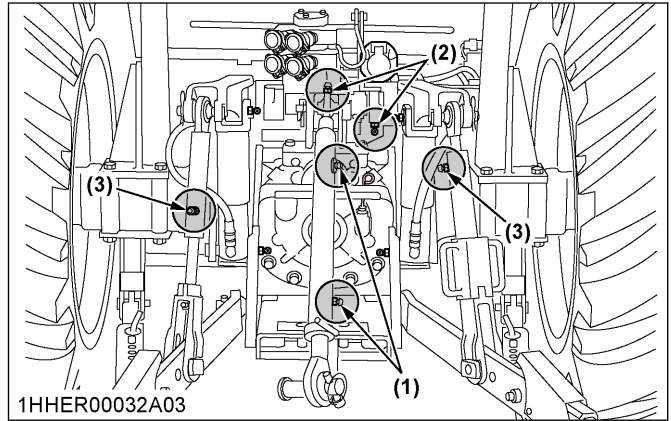

(1) Grease fitting (top link)
 (2) Grease fitting (top link bracket)
 (3) Grease fitting (lifting rod)

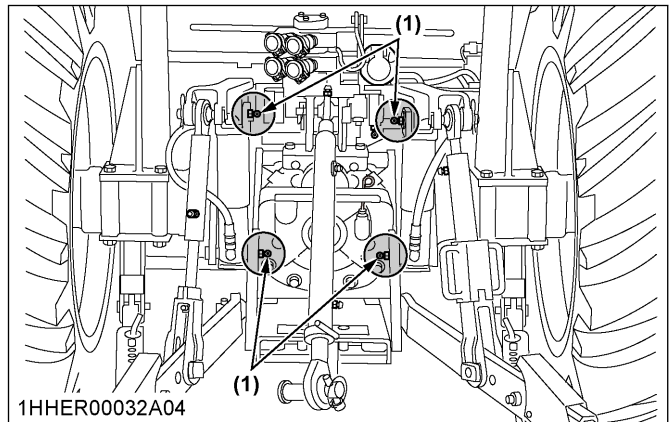

(1) Grease fitting (hydraulic lift cylinders pin)

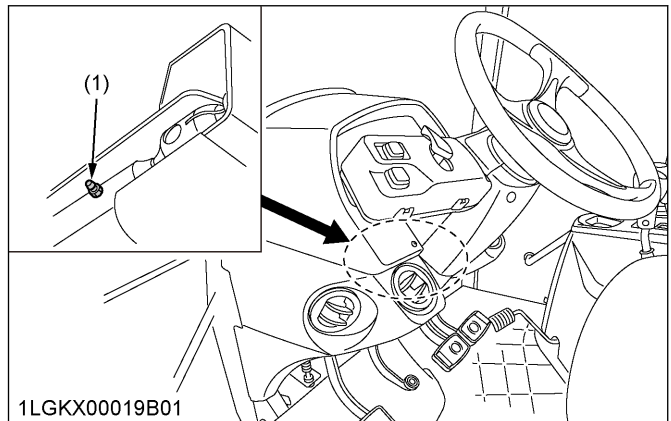

(1) Grease fitting (steering joint shaft)

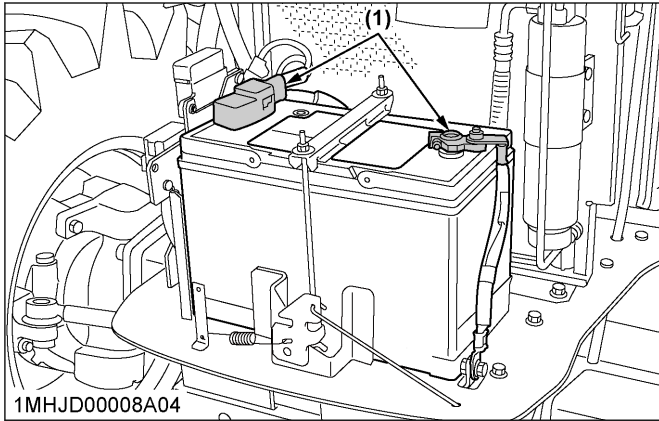

(1) Battery terminals

2. Cleaning air cleaner primary element

NOTE :

- If the air conditioner condenser is pulled out when cleaning the air cleaner, the air cleaner cover can be detached and attached easily. (See Cleaning grill, radiator screen, oil cooler, fuel cooler, air conditioner condenser and battery mount on page 113.)

1. Remove the air cleaner cover and primary element.
2. Clean the primary element:
 - When dry dust adheres to the element, blow compressed air from the inside, turning the element. Pressure of compressed air must be under 205 kPa (2.1 kgf/cm² , 30 psi).
 - When carbon or oil adheres to the element, soak the element in detergent for 15 minutes, then wash it several times in water, rinse with clean water and dry it naturally. After the element has fully dried, inspect inside the element with a light and check for damage.
3. Replace the air cleaner primary element: Once every 1000 hours or yearly, whichever comes first.

NOTE :

- Check to see if the evacuator valve is blocked with dust.

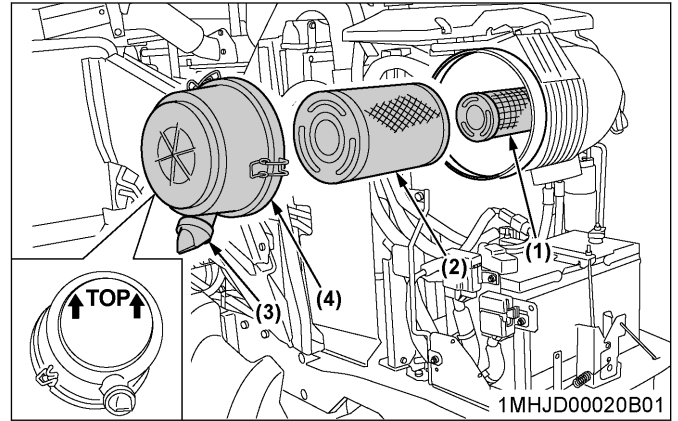

(1) Secondary (safety) element
 (2) Primary element
 (3) Evacuator valve
 (4) Cover

IMPORTANT :

- The air cleaner uses a dry element; never apply oil.
- Do not run the engine with the filter element removed.
- Be sure to refit the cover with the arrow ↑ (on the rear of the cover) upright. If the cover is improperly fitted, the evacuator valve will not function and dust will adhere to the element.
- Do not touch the secondary element except in cases where replacing is required. (See Replacing air cleaner primary element and secondary element on page 131.)

Evacuator valve

Open and clean the evacuator valve to get rid of large particles of dust and dirt (once a week under ordinary conditions, or daily when used in a dusty place).

3. Adjusting fan belt tension

⚠ WARNING

To avoid personal injury or death:

- Be sure to stop the engine before checking the belt tension.

Proper fan belt tension	A deflection of between 13 to 15 mm when the belt is pressed in the middle of the span.
-------------------------	---

1. Stop the engine and remove the key.
2. Apply moderate thumb pressure to the belt between pulleys.
3. If the tension is incorrect, loosen the alternator mounting bolts and turn the adjusting bolt to adjust the belt tension within acceptable limits.

4. Replace the fan belt if it is damaged.

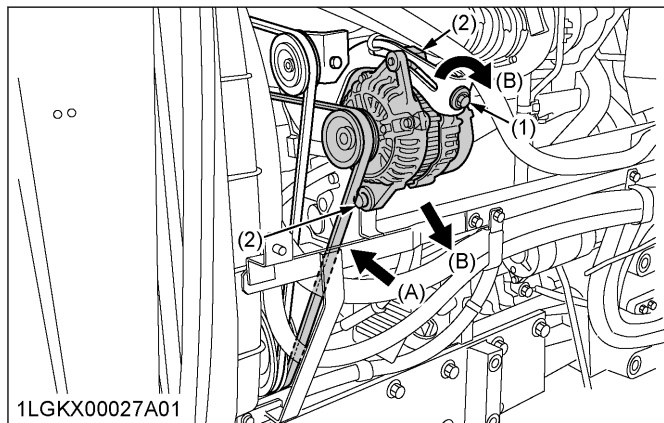

(1) Adjusting bolt (A) Check the belt tension
(2) Alternator mounting bolt (B) To tighten

4. Adjusting brake pedal

! WARNING

To avoid personal injury or death:

- Park on flat ground, stop the engine and chock the wheels before checking the brake pedal.
- To prevent uneven braking, the specification must be within the recommended limit. If found to be beyond the specification range, contact your local KUBOTA Dealer for adjusting the brakes.

4.1 Checking brake pedal free travel

Proper brake pedal free travel	7 to 14 mm on the pedal
	Keep the free travel in the right and left brake pedals equal.

1. Set both parking brakes.
2. Slightly depress the brake pedals and measure free travel at the top of pedal stroke.

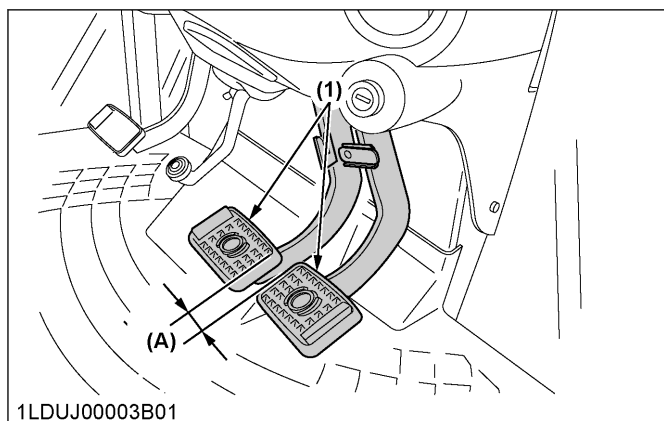

(1) Brake pedals (A) "FREE TRAVEL"

NOTE :

- Brake pedals should be equal when depressed.

4.2 Checking brake pedal stroke

Pedal stroke	Less than 100 mm at each pedal
--------------	--------------------------------

1. Disengage the brake pedal lock.
2. Depress the brake pedal several times.
3. Step on the right-hand pedal and measure the level difference (pedal stroke) between this pedal and the left-hand pedal.
4. Do the same for the left-hand pedal.

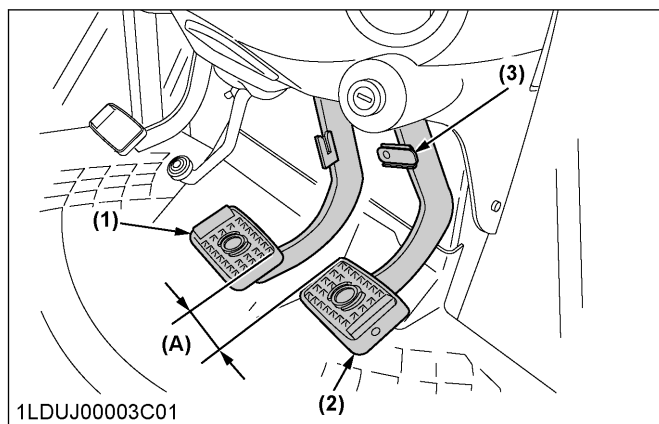

(1) Brake pedal (LH) (A) "PEDAL STROKE"
(2) Brake pedal (RH)
(3) Brake pedal lock

4.3 Checking equalizer working level (anti-imbalance device)

Equalizer working level	Minimum level difference of 5 mm between both pedals
-------------------------	--

1. Gently step on both brake pedals at once.
2. Further step on the right-hand pedal (the left-hand pedal slightly raises itself) and measure the level difference between the pedals.
3. Do the same for the left-hand pedal.

5. Checking gear-locked parking brake

! WARNING

To avoid personal injury or death:

- Do not dismantle the tractor while checking the gear-locked parking brake.

Confirm the tractor (tractor unit only) can surely be parked on the slope of about 15 degrees (slope that rises by 2.7 meters every 10 meters).

If the tractor moves, consult your local KUBOTA Dealer. Always engage the gear-locked parking brake before dismounting the tractor.

6. Adjusting parking brake lever

! WARNING

To avoid personal injury or death:

- Park on flat ground, stop the engine, and chock the wheels before checking the parking brake.

Proper parking brake lever free travel	3 to 5 notches (ratchet sound 3 to 5)
--	---------------------------------------

1. Raise the parking brake lever to the parking position while counting the ratchet sound made by the parking brake lever.
2. If adjustment is needed, loosen the lock nut and adjust the parking brake cable length within acceptable limits.
3. Retighten the lock nut.

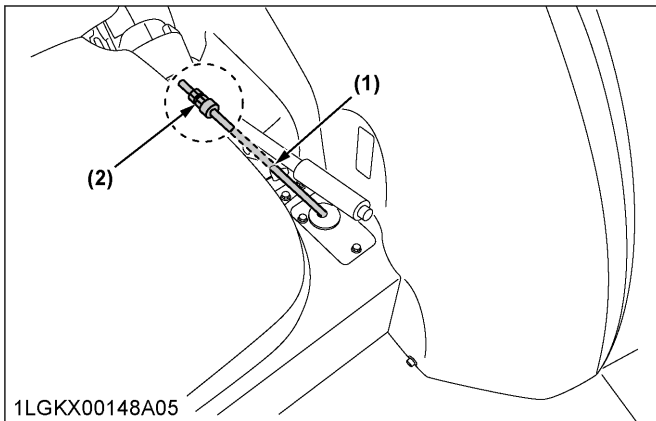

1LGKX00148A05
 (1) Parking brake cable
 (2) Lock nut (x2)

7. Checking battery condition

! DANGER

To avoid the possibility of battery explosion: For the refillable type battery, follow the instructions below.

- Do not use or charge the refillable type battery if the fluid level is below the [LOWER] (lower limit level) mark. Otherwise, battery component parts may prematurely deteriorate, which may shorten the battery's service life or cause an explosion. Check the fluid level regularly and add distilled water as required so that the fluid level is between the [UPPER] and [LOWER] levels.

! WARNING

To avoid personal injury or death:

- Never remove the battery cap while the engine is running.
- Keep electrolyte away from eyes, hands, and clothes. If you are splattered with it, wash it away completely with water immediately and get medical attention.
- Keep open sparks and flames away from the battery at all times. Hydrogen gas mixed with oxygen becomes very explosive.
- Wear eye protection and rubber gloves when working around the battery.

NOTE :

- The factory-installed battery is a non-refillable type. If the indicator turns white, do not charge the battery but replace it with a new one.

Mishandling the battery shortens the service life and adds to maintenance costs.

The original battery is maintenance-free, but needs some servicing.

If the battery is weak, the engine will be difficult to start, and the lights will be dim. It is important to check the battery periodically.

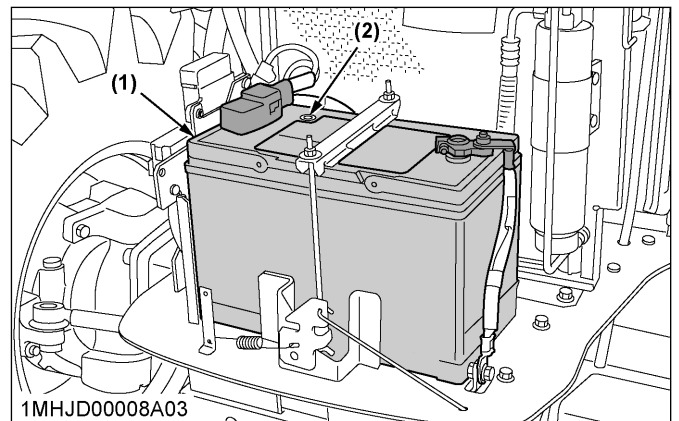

(1) Battery
 (2) Indicator

7.1 How to read indicator

Check the battery condition by reading the indicator.

Green	Specific gravity of electrolyte and quality of electrolyte are both in good condition.
Black	Battery needs charging.
White	Battery needs replacing.

NOTE :

- When viewing the indicator, check from directly above by removing the air cleaner cover or using a mirror.

7.2 Charging the battery

WARNING

To avoid personal injury or death:

- When the battery is being activated, hydrogen and oxygen gases in the battery are extremely explosive. Keep open sparks and flames away from the battery at all times, especially when charging the battery.
- When charging the battery, ensure the vent caps are securely in place (if equipped).
- When disconnecting the cable from the battery, start with the negative terminal first. When connecting the cable to the battery, start with the positive terminal first.
- Never check battery charge by placing a metal object across the posts. Use a voltmeter or hydrometer.

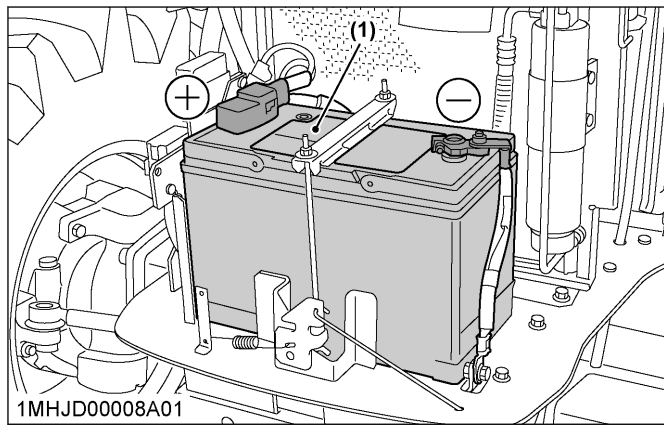

(1) Battery

1. To slow charge the battery, connect the battery positive terminal to the charger positive terminal and the negative to the negative, then recharge in the standard fashion.
2. A boost charge is only for emergencies. It will partially charge the battery at a high rate and in a short time. When using a boost-charged battery, it is necessary to recharge the battery as early as possible. Failure to do this will shorten the battery's service life.
3. The battery is charged when the indicator display turns from black to green.
4. When exchanging an old battery for a new one, use a battery of equivalent specification to those shown in the following table.

Table 1

Battery type	Volts (V)	Capacity at 5H.R (A.H)
GP31 (105E41R)	12	80

Reserve capacity (min)	Cold cranking amps	Normal charging rate (A)
160	900	11

7.3 Directions for battery storage

1. When storing the tractor for long periods of time, remove the battery from the tractor, adjust the electrolyte to the proper level and store in a dry place out of direct sunlight.
2. The battery self-discharges while it is stored. Recharge it once every 3 months in hot seasons and once every 6 months in cold seasons.

8. Adjusting air conditioner belt tension

WARNING

To avoid personal injury or death:

- Be sure to stop the engine before checking the belt tension.

Proper air conditioner belt tension	A deflection of between 10 to 12 mm when the belt is pressed (98 N / 10 kgf) in the middle of the span.
-------------------------------------	---

1. Stop the engine and remove the key.
2. Apply moderate thumb pressure to belt between pulleys.
3. If tension is incorrect, loosen the tension pulley mounting nut and turn the adjusting bolt to adjust the belt tension within acceptable limits.
4. Replace air conditioner belt if it is damaged.

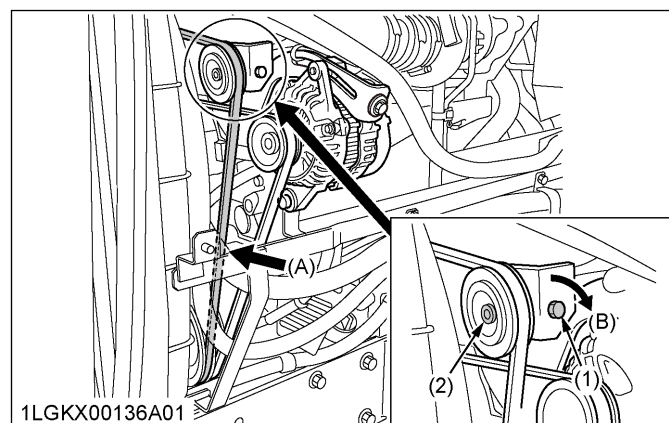

- (1) Adjusting bolt (A) Check the belt tension
 (2) Tension pulley mounting nut (B) To tighten

EVERY 200 HOURS

1. Adjusting toe-in

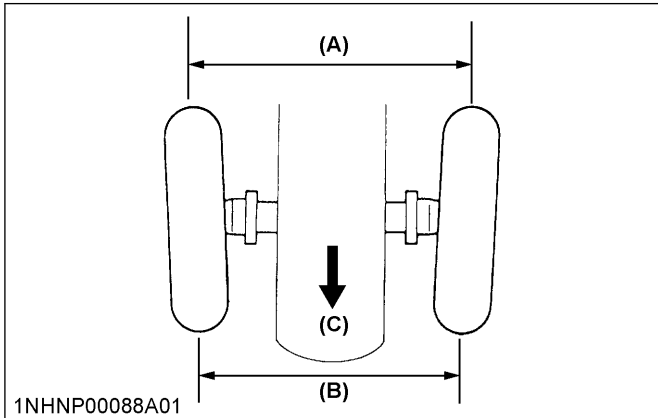

- (A) Wheel-to-wheel distance at the rear
- (B) Wheel-to-wheel distance at the front
- (C) "FRONT"

Proper toe-in	2 to 8 mm
---------------	-----------

1. Park the tractor on a flat surface.
2. Turn the steering wheel so that the front wheels are in the straight-ahead position.
3. Lower the implement, apply both parking brakes and stop the engine.
4. Measure the distance between the tire beads at the front of the tire, at hub height.
5. Measure the distance between the tire beads at the rear of the tire, at hub height.
6. The front distance should be shorter than the rear distance. If not, adjust the tie rod length.

1.1 Adjusting toe-in procedure

1. Detach the snap ring.
2. Loosen the tie-rod nut.
3. Turn the tie-rod joint to adjust the rod length until the proper toe-in measurement is obtained.
4. Retighten the tie-rod nut.
5. Attach the snap ring of the tie-rod joint.

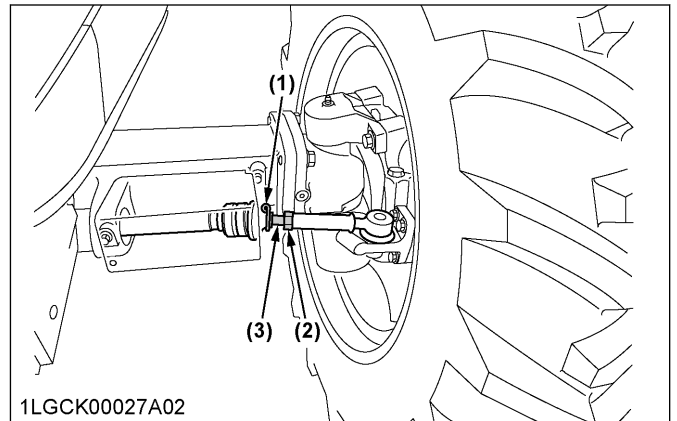

- (1) Snap ring (both sides, RH not shown in illustration)
- (2) Tie-rod nut (both sides, RH not shown in illustration)
167 to 196 N · m
17 to 20 kgf · m
- (3) Tie-rod joint (both sides, RH not shown in illustration)

2. Draining fuel tank water

Loosen the drain plug at the bottom of the fuel tank to let sediments, impurities, and water out of the tank. Finally, tighten up the plug.

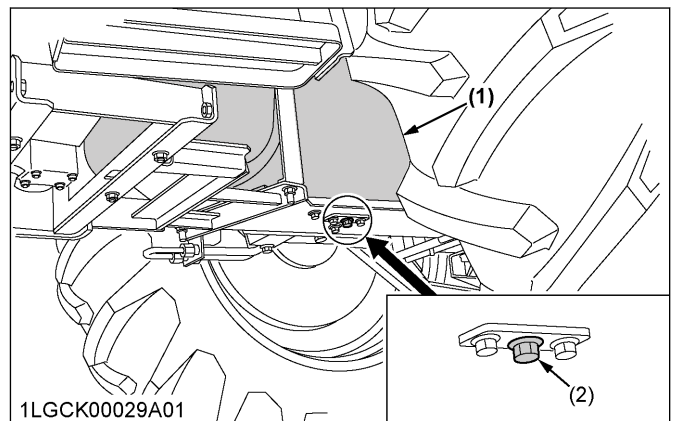

- (1) Fuel Tank (left)
- (2) Drain plug

IMPORTANT :

- If the fuel contains impurities, such as water, drain the fuel tank at shorter intervals.
- Drain the fuel tank before operating the tractor after a long period of storage.
- The fuel tank is made of plastic. Be careful not to overtighten the bolts.

3. Cleaning inner air filter

Remove the knob bolts and pull out the filter. Blow air from the direction opposite to the filter's normal air flow. Pressure of compressed air must be under 205 kPa (2.1 kgf/cm² / 30 psi).

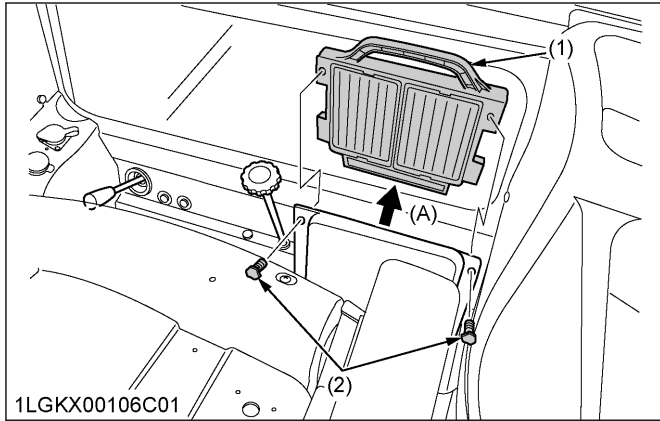

1LGKX00106C01
 (1) Inner air filter (A) "PULL OUT"
 (2) Knob bolts

4. Cleaning fresh air filter

Remove the knob bolts and pull out the filter.

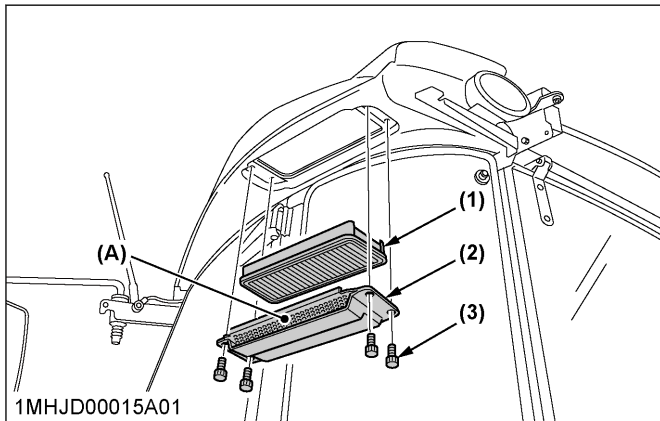

1MHJD00015A01
 (1) Fresh air filter (A) Air inlet port
 (2) Cover
 (3) Knob bolt

NOTE :

- After cleaning, attach the filter and cover as in the previous illustration.

4.1 Cleaning the filter

Normal use

Blow air from the opposite direction to the filter's normal air flow.

Pressure of compressed air must be under 205 kPa (2.1 kgf/cm² / 30 psi).

IMPORTANT :

- Do not hit the filter. If the filter becomes deformed, dust may enter into the air-conditioner, which may cause damage and malfunction.

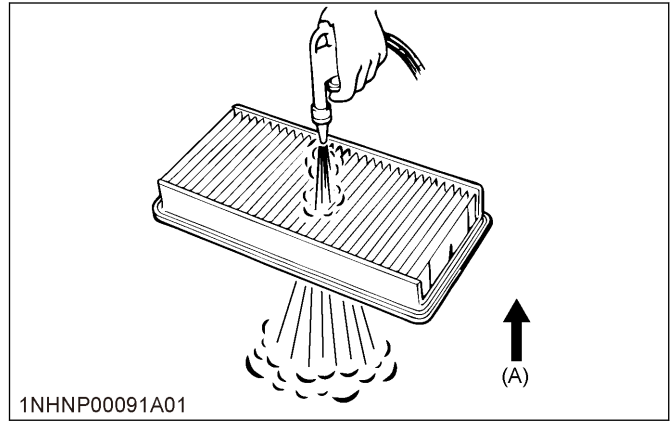

1NHNP00091A01
 (A) "AIR CONDITIONER AIRFLOW"

NOTE :

- If the filter is very dirty:
 Dip the filter in lukewarm water with mild dishwashing detergent.
 Move it up and down as well as left and right to loosen dirt. Rinse the filter with clean water and let it air-dry.

IMPORTANT :

- Do not use gasoline, thinner or similar chemicals to clean the filter as damage to the filter may occur.
- It may also cause an unpleasant odor in the CAB next time the system is used.

EVERY 400 HOURS

1. Cleaning water separator

This job should not be done in the field, but in a clean environment.

1. Disconnect the water sensor connector.
2. Close the fuel shutoff-valve.
3. Unscrew the cup and remove it, then rinse the inside with kerosene.
4. Take out the element and dip it in the kerosene to rinse.
5. After cleaning, reassemble the water separator, keeping out dust and dirt.
6. Connect the water sensor connector.

7. Bleed the fuel system.
(See Bleeding fuel system on page 134.)

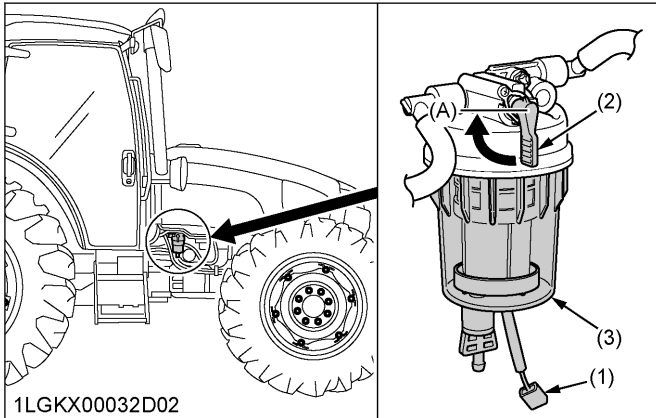

- (1) Water sensor connector (A) "CLOSE"
(2) Fuel shutoff-valve
(3) Cup

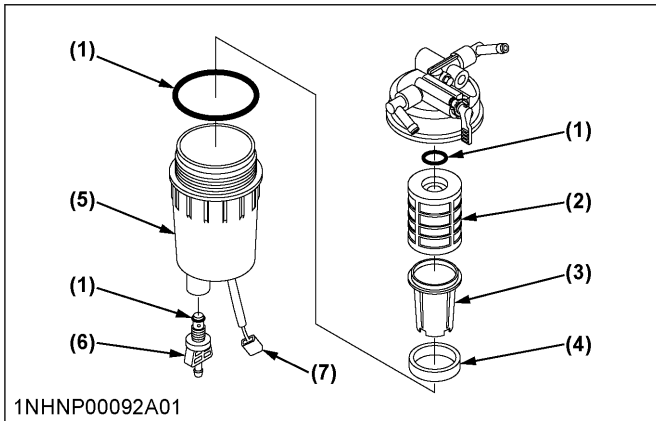

- (1) O ring (5) Cup
(2) Element (6) Drain plug
(3) Element cup (7) Water sensor connector
(4) Red float

IMPORTANT :

- If the water separator and/or fuel filter is not well maintained, the supply pump and injector may be damaged earlier than expected.

EVERY 500 HOURS

1. Changing engine oil

⚠ WARNING

To avoid personal injury or death:

- Be sure to stop the engine before changing the oil.
- Allow the engine to cool down sufficiently; oil can be hot and can burn.

1. To drain the used oil, remove the drain plug at the bottom of the engine and drain the oil completely into the oil pan.

2. After draining, reinstall the drain plug.
3. Fill with new oil up to the upper notch on the dipstick.
(See LUBRICANTS, FUEL AND COOLANT on page 108.)

Oil capacity with filter	10.7 L
--------------------------	--------

IMPORTANT :

- Use DPF-compatible oil (CJ-4) for the engine.

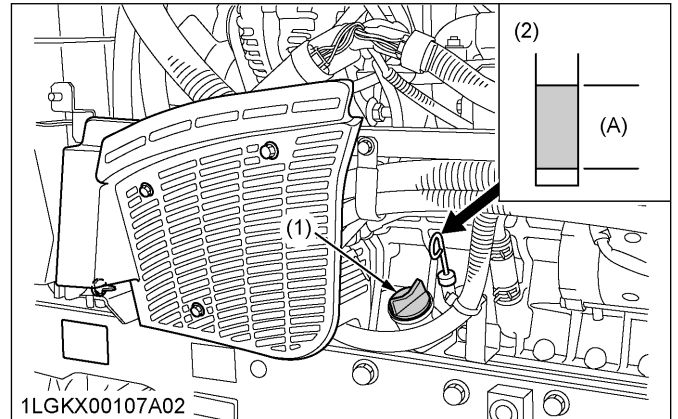

- (1) Oil inlet (A) Oil level is acceptable within this range
(2) Dipstick

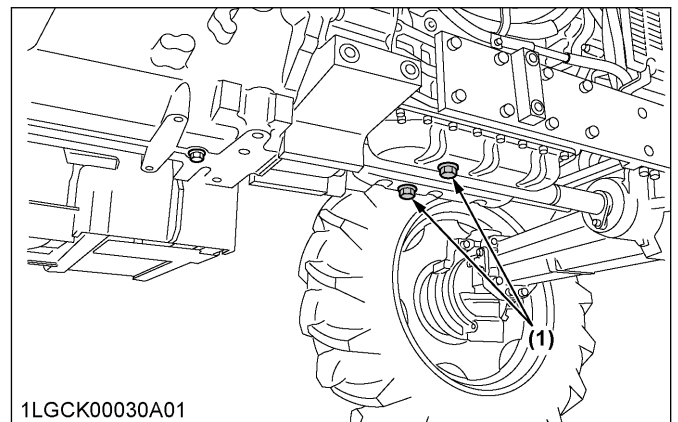

- (1) Drain plug

2. Replacing engine oil filter

⚠ WARNING

To avoid personal injury or death:

- Be sure to stop the engine before replacing the oil filter cartridge.
- Allow the engine to cool down sufficiently; oil can be hot and can burn.

1. Remove the oil filter.
2. Put a film of clean engine oil on the rubber seal of the new filter.

3. Tighten the filter quickly until it contacts the mounting surface.
Tighten the filter by hand an additional 1/2 turn only.
4. After the new filter has been replaced, the engine oil normally decreases by a small amount. Make sure that the engine oil does not leak through the seal and be sure to check the oil level on the dipstick. Then replenish the engine oil up to the prescribed level.

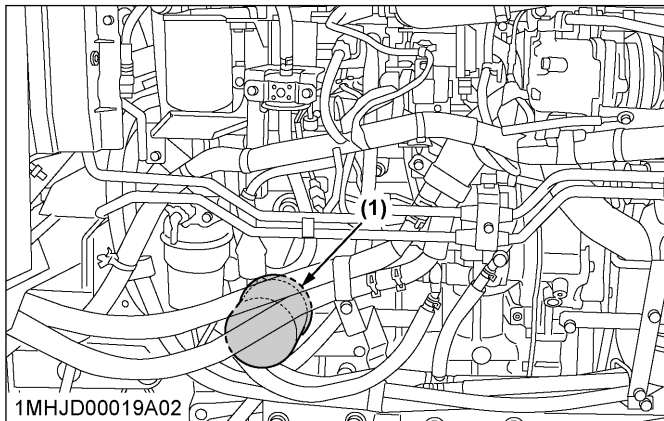

1MHJD00019A02

(1) Engine oil filter

IMPORTANT :

- To prevent serious damage to the engine, use only a Kubota genuine filter.

3. Replacing fuel filter

1. Remove the fuel filter.
2. Put a film of clean fuel on the rubber seal of the new filter.
3. Tighten the filter quickly until it contacts the mounting surface.
Tighten the filter by hand an additional 1/2 turn only.
4. Bleed the fuel system.
(See Bleeding fuel system on page 134.)

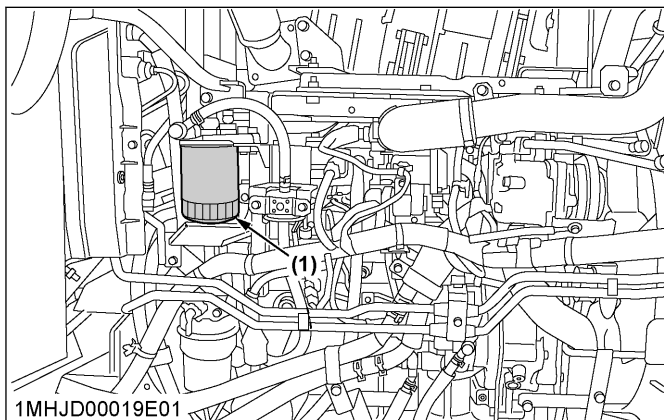

1MHJD00019E01

(1) Fuel filter

4. Replacing hydraulic oil filter

WARNING

To avoid personal injury or death:

- Be sure to stop the engine before changing the oil filter cartridge.
- Allow the engine to cool down sufficiently; oil can be hot and can burn.

1. Remove the drain plug at the bottom of the transmission case and drain the oil completely into an oil pan.
2. After draining reinstall the drain plug.

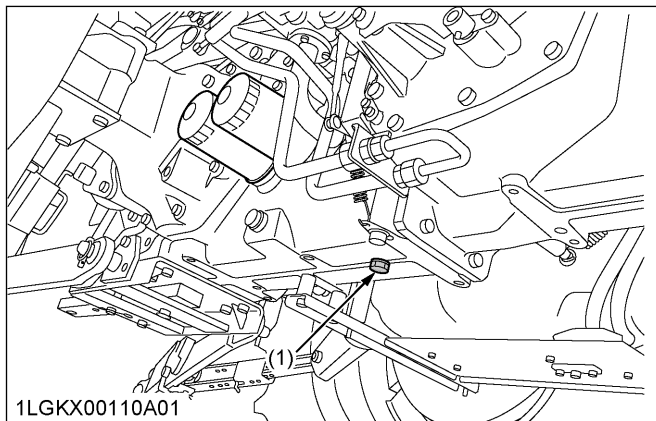

1LGKX00110A01

(1) Drain plug

3. Remove the 2 oil filters.
4. Wipe off metal filings from the magnetic filter with a clean rag.

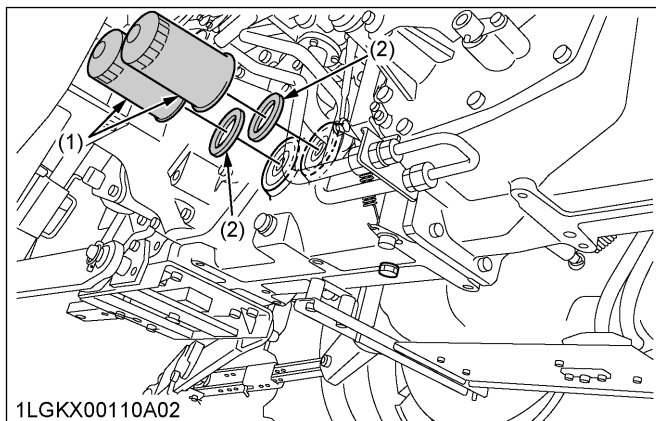

1LGKX00110A02

(1) Hydraulic oil filter
(2) Magnetic filter (wipe off metal filings)

5. Put a film of clean transmission oil on the rubber seal of the new filters.
6. Tighten the filter quickly until it contacts the mounting surface.
Tighten filter by hand an additional 1/2 turn only.

- After the new filters have been replaced, fill the transmission oil up to the upper notch on the dipstick.

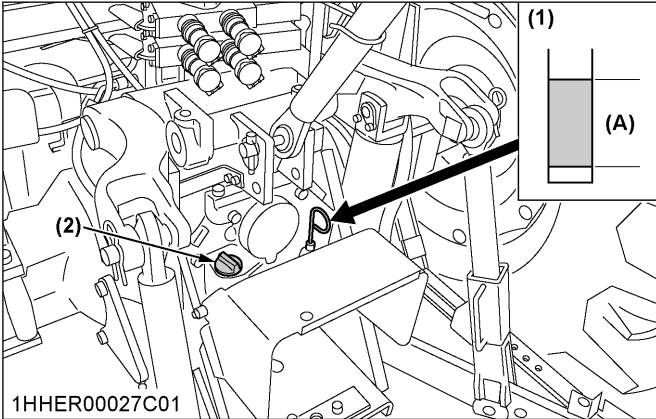

(1) Gauge (A) Oil level is acceptable within this range.

- After running the engine for a few minutes, stop the engine and check the oil level again, add oil to the prescribed level.
- Make sure that the transmission fluid does not leak past the seal on the filter.

IMPORTANT :

- To prevent serious damage to the hydraulic system, use only a KUBOTA genuine filter.

5. Checking power steering line

- Check to see that all lines and hose clamps are tight and not damaged.
- If the hoses and clamps are found to be worn or damaged, replace or repair them at once.

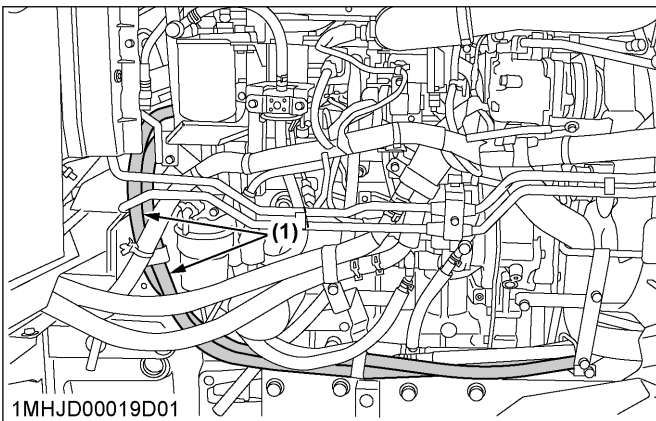

(1) Power steering pressure hoses

6. Checking radiator hose and clamp

Check to see if the radiator hoses are properly fixed every 500 hours of operation.

- If the hose clamps are loose or water leaks, tighten the bands securely.

- Replace the hoses and tighten the hose clamps securely, if the radiator hoses are swollen, hardened or cracked. Replace the hoses and hose clamps every 4 years or earlier if they are found to be swollen, hardened or cracked.

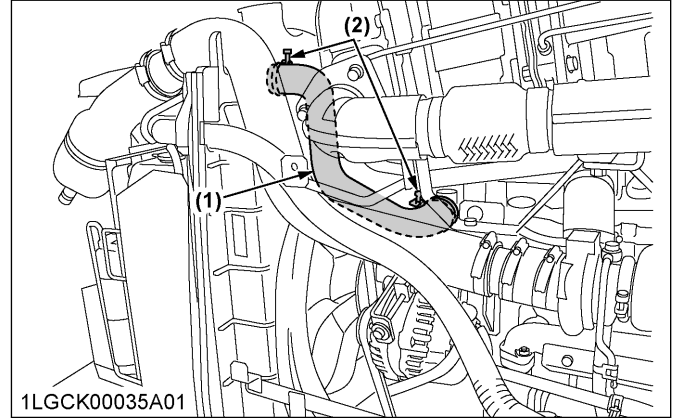

(1) Radiator hoses (2) Hose clamps

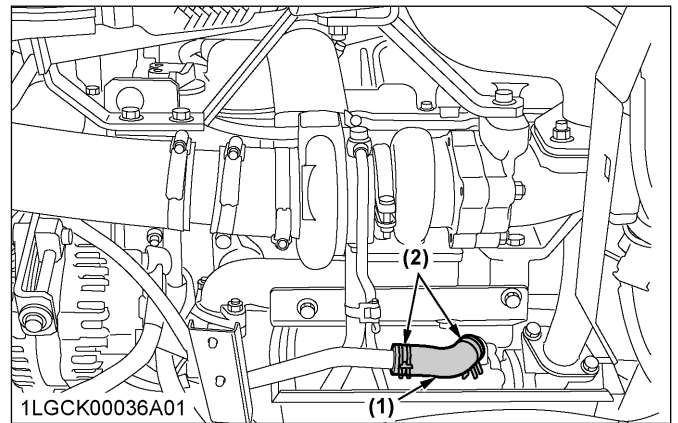

(1) Radiator hoses (2) Hose clamps

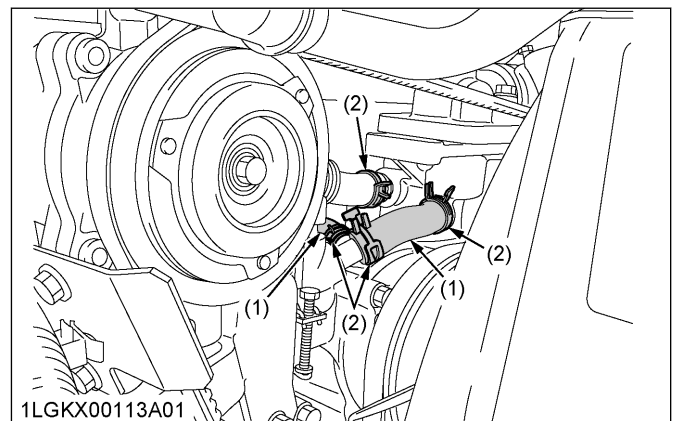

(1) Radiator hoses (2) Hose clamps

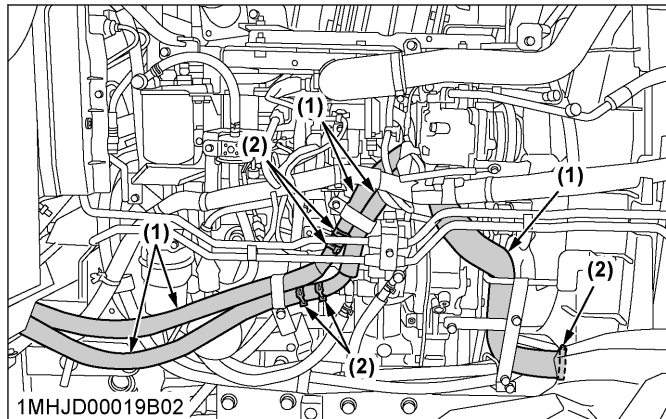

(1) Radiator hoses
(2) Hose clamps

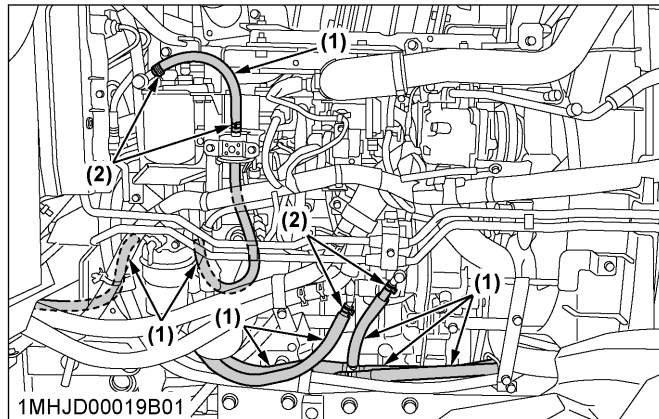

(1) Fuel lines
(2) Clamp bands

6.1 Overheating countermeasures

Take the following actions in the event the coolant temperature is nearly at or over the boiling point, also called "overheating".

1. Park the tractor in a safe place and keep the engine idling unloaded.
2. Allow the engine to idle unloaded for about 5 minutes before stopping it, rather than stopping it suddenly.
3. Keep away from the machine for another 10 minutes or while the steam blows out.
4. Check that there are no dangers such as burns. Get rid of the causes of overheating according to the troubleshooting section of this manual. (See TROUBLESHOOTING on page 141.)
Afterward, restart the engine.

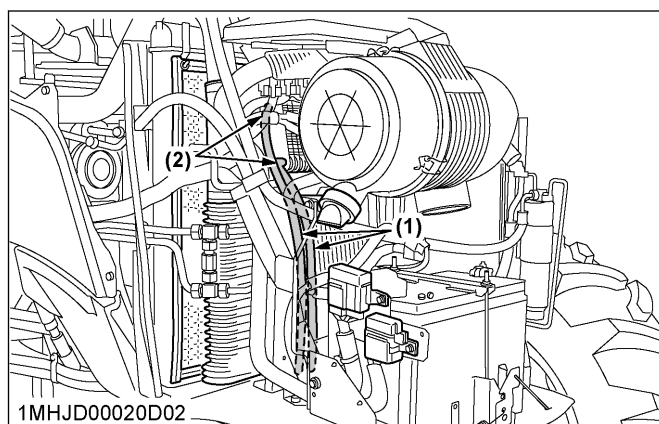

(1) Fuel lines
(2) Clamp bands

NOTE :

- If the fuel line has been replaced, be sure to properly bleed the fuel system. (See Bleeding fuel system on page 134.)

7. Checking fuel line

1. Check to see that all lines and hose clamps are tight and not damaged.
2. If the hoses and clamps are found to be worn or damaged, replace or repair them at once.

8. Checking intake air line

1. Check to see that hoses and hose clamps are tight and not damaged.

2. If the hoses and clamps are found to be worn or damaged, replace or repair them at once.

M5091

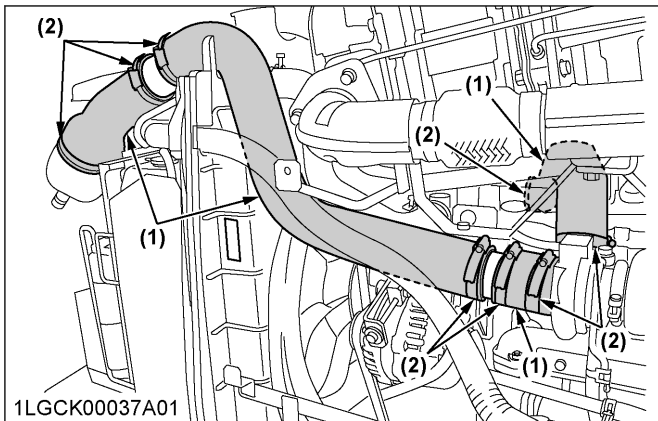

- (1) Hose
- (2) Hose clamps

M5111

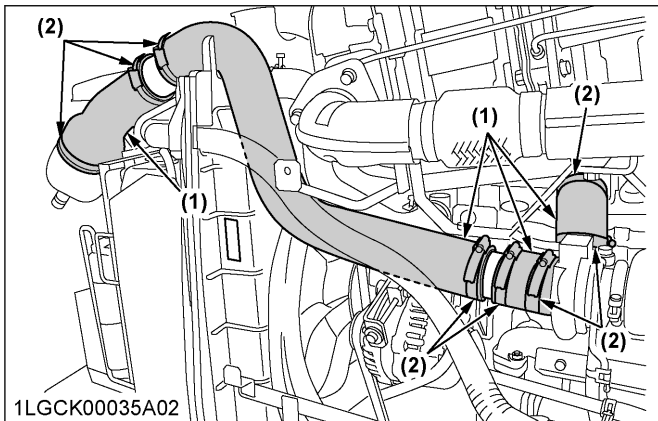

- (1) Hose
- (2) Hose clamps

M5111

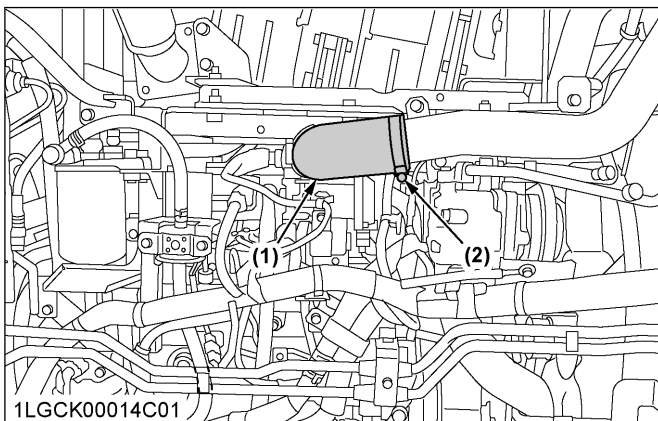

- (1) Hose
- (2) Hose clamps

M5111

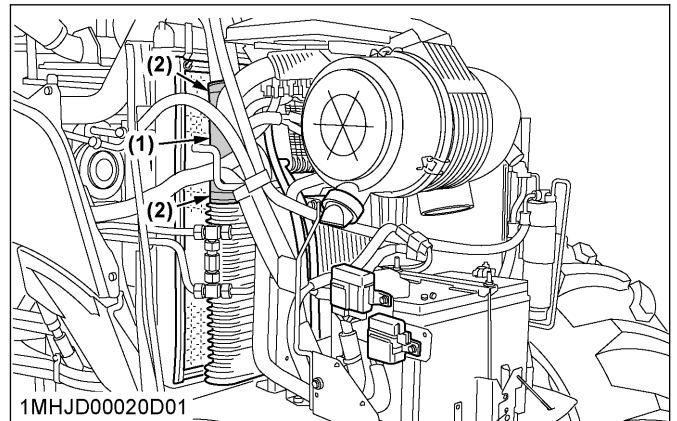

- (1) Hose
- (2) Hose clamps

M5111

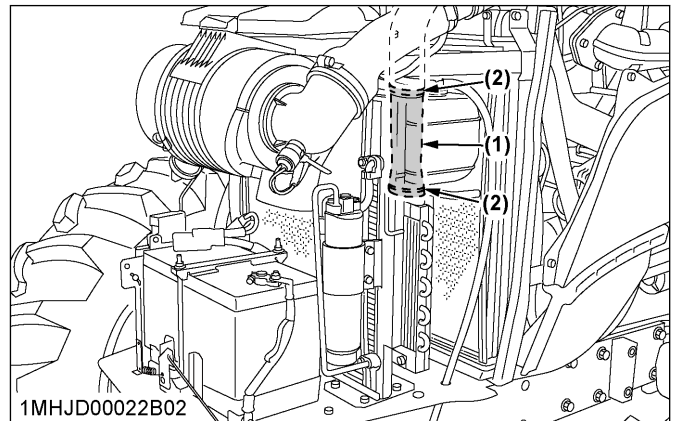

- (1) Hose
- (2) Hose clamps

9. Checking lift cylinder hose

1. Check to see that hoses and hose clamps are tight and not damaged.
2. If hoses and clamps are found worn or damaged, replace or repair them at once.

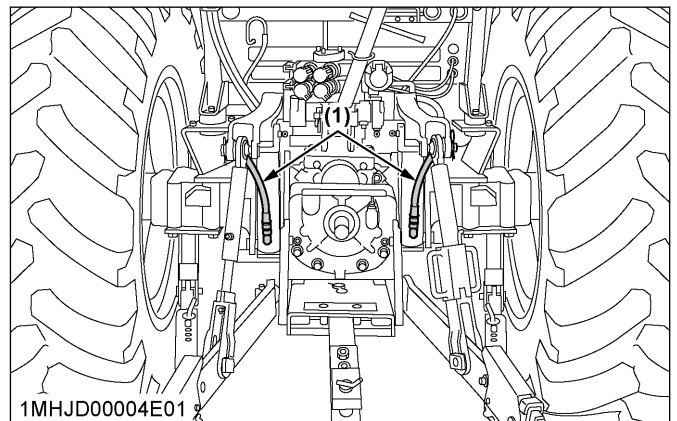

- (1) Lift cylinder hoses

10. Checking air conditioner pipe and hose

1. Check to see that all lines and hose clamps are tight and not damaged.
2. If hoses and clamps are found to be worn or damaged, consult your local KUBOTA Dealer for this service.

EVERY 600 HOURS

1. Adjusting front axle pivot

If the front axle pivot pin adjustment is incorrect, front wheel vibration can occur, causing vibration in the steering wheel.

Adjusting procedure

1. Loosen the lock nut and screw-in the adjusting screw until seated.
2. Tighten the screw by an additional 1/6 turn.
3. Re-tighten the lock nut.

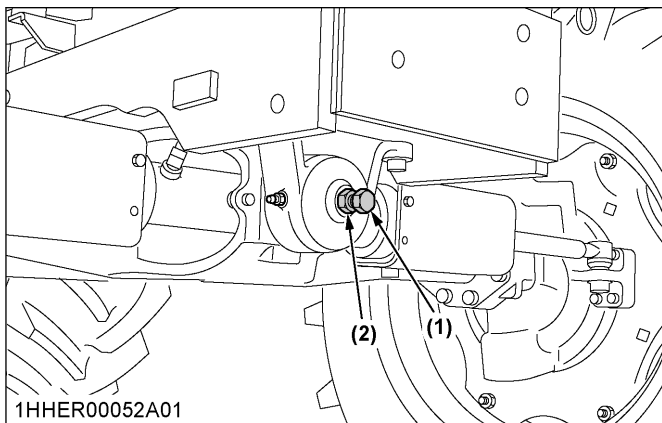

1HHER00052A01
 (1) Adjusting screw
 (2) Lock nut

EVERY 1000 HOURS

1. Changing transmission fluid

WARNING

To avoid personal injury or death:

- Allow the engine to cool down sufficiently; oil can be hot and can burn.
1. To drain the used oil, remove the drain plug at the bottom of the transmission case and drain the oil completely into the oil pan.
 2. After draining, reinstall the drain plug.
 3. Fill with new **KUBOTA SUPER UDT** fluid up to the upper notch on the dipstick.
 (See LUBRICANTS, FUEL AND COOLANT on page 108.)

4. After running the engine for a few minutes, stop the engine, check the oil level again, and add oil to the prescribed level, if necessary.

Oil capacity	60 L
--------------	------

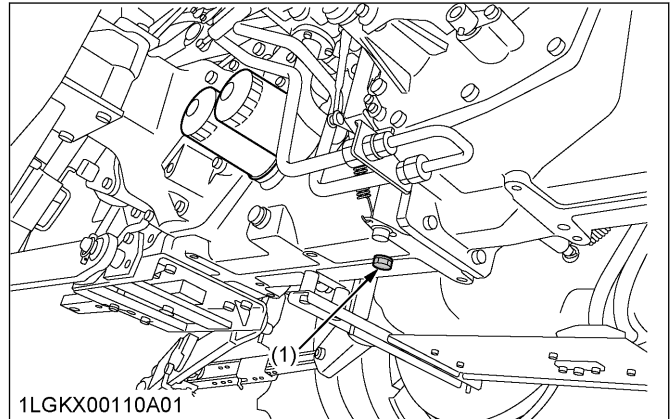

1LGKX00110A01
 (1) Drain plug

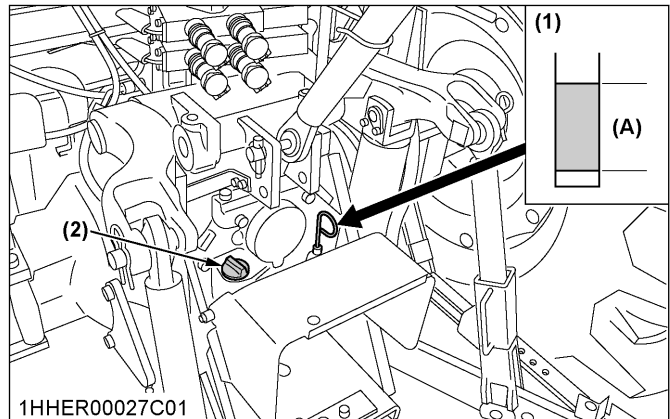

1HHER00027C01
 (1) Dipstick
 (2) Oil inlet
 (A) Oil level is acceptable within this range.

IMPORTANT :

- Do not operate the tractor immediately after changing the transmission fluid.
 Run the engine at medium speed for a few minutes to prevent damage to the transmission.

2. Changing front differential case oil

1. To drain the used oil, remove the drain and filling plug at the front differential case and drain the oil completely into the oil pan.
2. After draining, reinstall the drain plug.
3. Remove the oil level check plug.
4. Fill with the new oil up to the lower rim of check plug port.
 (See LUBRICANTS, FUEL AND COOLANT on page 108.)

5. After filling, reinstall the filling plug and check plug.

Oil capacity	6.0 L
--------------	-------

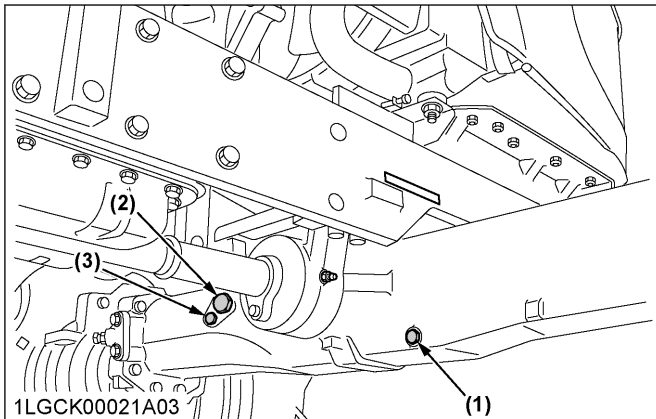

- (1) Drain plug
- (2) Filling plug
- (3) Check plug

3. Changing front axle gear case oil

1. To drain the used oil, remove the right and left drain plugs and filling plugs at the front axle gear case and drain the oil completely into the oil pan.
2. After draining, reinstall the drain plugs.
3. Fill with the new oil up to the filling plug port. (See LUBRICANTS, FUEL AND COOLANT on page 108.)
4. After filling, reinstall the filling plugs.

Oil capacity	3.5 L for each side
--------------	---------------------

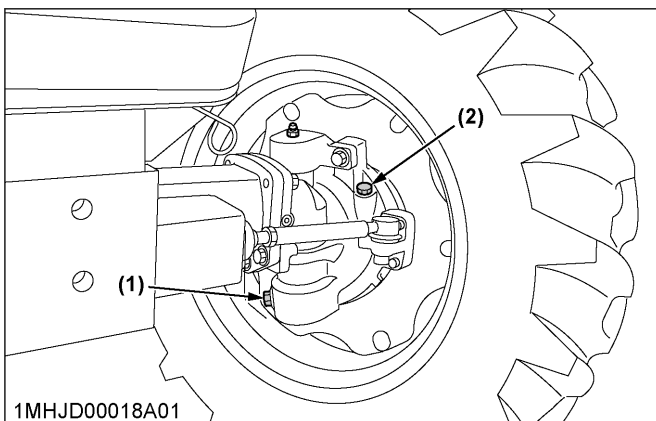

- (1) Drain plug (both sides, RH not shown in illustration)
- (2) Filling plug (both sides, RH not shown in illustration)

4. Adjusting engine valve clearance

Consult your local KUBOTA Dealer for this service.

EVERY 1000 HOURS OR 1 YEAR

Be sure to do the following servicing once every 1000 hours or yearly, whichever comes first.

1. Replacing air cleaner primary element and secondary element

(See Cleaning air cleaner primary element on page 119.)

2. Checking exhaust manifold

Consult your local KUBOTA Dealer for this service.

EVERY 1500 HOURS

1. Cleaning fuel injector nozzle tip

Consult your local KUBOTA Dealer for this service.

2. Checking and cleaning EGR cooler

Consult your local KUBOTA Dealer for this service.

EVERY 2000 HOURS OR 2 YEARS

Be sure to do the following servicing once every 2000 hours or biennially, whichever comes first.

1. Flushing cooling system and changing coolant

⚠ WARNING

To avoid personal injury or death:

- Do not remove the radiator cap while the coolant is hot. When cool, slowly rotate the cap to the first stop and allow sufficient time for excess pressure to escape before removing the cap completely.

1. Stop the engine, remove the key and let it cool down.
2. To drain the coolant, open the radiator drain plug, remove the drain plug and remove the radiator cap. The radiator cap must be removed to completely drain the coolant.
3. After the coolant has drained, reinstall the drain plug.
4. Fill with clean soft water and cooling system cleaner.
5. Follow the cleaner instructions.

6. After flushing, fill with clean soft water and anti-freeze until the coolant level is just below the radiator cap.
Install the radiator cap securely.
7. Fill with coolant up to the **[FULL]** mark of the recovery tank.
8. Start up and operate the engine for a few minutes.
9. Stop the engine, remove the key and let it cool down.
10. Check the coolant level of the recovery tank and add coolant if necessary.
11. Properly dispose of the used coolant.

Coolant capacity	10 L
------------------	------

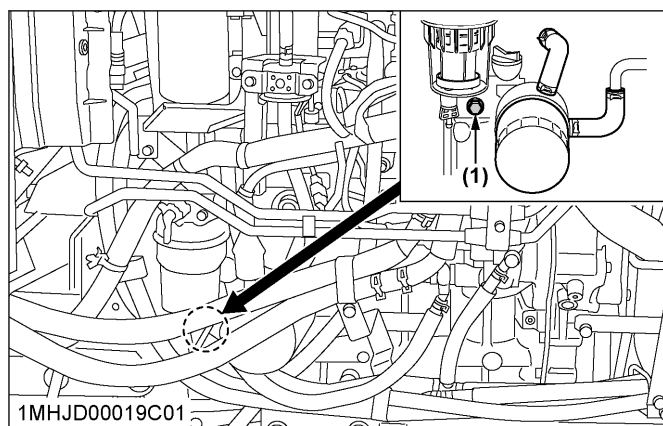

(1) Drain plug

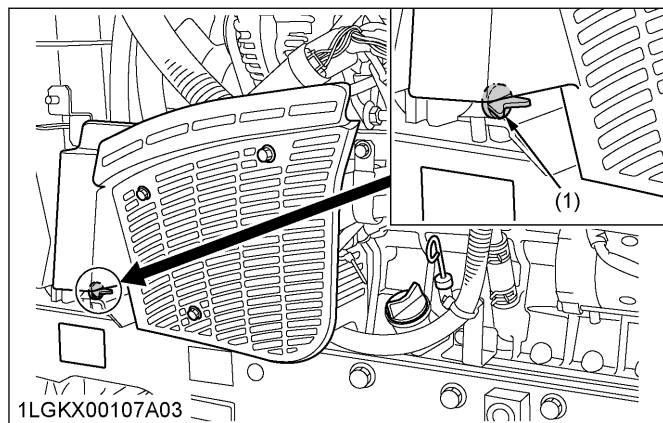

(1) Drain plug

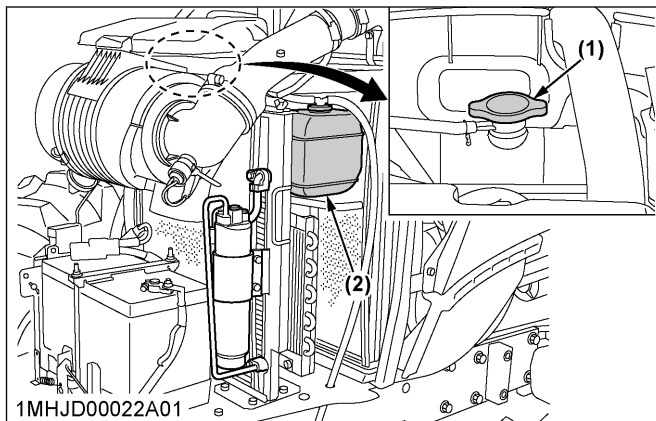

(1) Radiator cap
(2) Recovery tank

IMPORTANT :

- Do not start the engine without any coolant.
- Use clean, fresh soft water and antifreeze to fill the radiator and recovery tank.
- When mixing the antifreeze with water, the antifreeze mixing ratio is 50%.
- Securely tighten the radiator cap. If the cap is loose or improperly fitted, water may leak out and the engine could overheat.

NOTE :

- On CAB type machines, coolant circulates through the heater. This means that approximately one more liter of coolant is required.

In changing coolant, pour coolant up to the filler port of the recovery tank. Turn "ON" the heater (shift the temperature control dial toward "WARM"), and run the engine for a while in order to warm coolant. Then stop the engine.

When the coolant has cooled down, some of the coolant in the recovery tank is drawn into the pipes. Now the recovery tank is appropriately filled with coolant.

2. Antifreeze

! WARNING

To avoid personal injury or death:

- When using antifreeze, put on some protection such as rubber gloves (antifreeze contains poison).
- If you swallow the antifreeze, seek immediate medical help. Do not make a person throw up unless told to do so by a poison control or a healthcare professional. Use standard first aid and CPR for signs of shock or cardiac arrest. Call your local poison control center or your local emergency number for further assistance.

- **When antifreeze comes in contact with the skin or clothing, wash it off immediately.**
- **Do not mix different types of antifreeze. The mixture can produce chemical reactions resulting in harmful substances.**
- **Antifreeze is extremely flammable and explosive under certain conditions. Keep fire and children away from antifreeze.**
- **When draining fluids from the engine, place a container underneath the engine body.**
- **Do not pour waste onto the ground, down a drain, or into any water source.**
- **Also, observe the relevant environmental protection regulations when disposing of antifreeze.**

Always use a 50/50 mix of long-life coolant and clean soft water in Kubota engines.

Consult your local KUBOTA Dealer concerning coolant for extreme conditions.

1. Long-life coolant (hereafter LLC) comes in several types. Use ethylene glycol (EG) type for this engine.
2. Before employing LLC-mixed cooling water, fill the radiator with fresh water and empty it again. Repeat this procedure 2 or 3 times to clean up the inside.
3. **Mixing the LLC**
Premix 50% LLC with 50% clean soft water. When mixing, stir it up well, and then pour it into the radiator.
4. The procedure for the mixing of water and antifreeze differs according to the make of the antifreeze and the ambient temperature. Refer to SAE J1034 standard, more specifically also to SAE J814c.

Vol % antifreeze	Freezing point	Boiling point ^{*1}
	°C	°C
50	-37	108

*1 At 1.013 x 10⁵ Pa (760 mmHg) pressure (atmospheric). A higher boiling point is obtained by using a radiator pressure cap which permits the development of pressure within the cooling system.

5. **Adding the LLC**
 - a. Add only water if the mixture level is reduced by evaporation.
 - b. If there is a mixture leak, add LLC of the same manufacturer and type in the same mixture percentage.

IMPORTANT :

- **Never add any long-life coolant from a different manufacturer. Different brands may have different additive components, and the engine may fail to perform as specified.**

6. When the LLC is mixed, do not employ any radiator cleaning agent. The LLC contains anticorrosive agent. If mixed with the cleaning agent, sludge may build up, adversely affecting the engine parts.
7. Kubota's genuine long-life coolant has a service life of 2 years. Be sure to change the coolant every 2000 hours or every 2 years, whichever comes first.

NOTE :

- **The above data represents industry standards that necessitate a minimum glycol content in the concentrated antifreeze.**

EVERY 3000 HOURS

1. Checking turbocharger

Consult your local KUBOTA Dealer for this service.

2. Checking supply pump

Consult your local KUBOTA Dealer for this service.

3. Checking intake air heater

Consult your local KUBOTA Dealer for this service.

4. Checking and cleaning EGR system

Consult your local KUBOTA Dealer for this service.

5. Cleaning DPF muffler

1. Remove the ash.
The longer the DPF operates, the more ash (burnt residue) is collected in the filter. Too much ash build-up adversely affects the DPF performance. Consult your local KUBOTA Dealer to clean the filter.

IMPORTANT :

- **The DPF needs to be cleaned with a specific cleaning device. Do not disassemble the DPF for cleaning or attempt to clean it yourself. Consult your local KUBOTA Dealer.**

EVERY 1 YEAR

1. Checking CAB isolation cushion

Check the cushion for any breakage or fatigue. Replace them if they have deteriorated.

2. Checking DPF related pipe

Consult your local KUBOTA Dealer for this service.

3. Checking EGR pipe

Consult your local KUBOTA Dealer for this service.

EVERY 2 YEARS

1. Replacing breather related rubber pipe

Consult your local KUBOTA Dealer for this service.

2. Replacing boost sensor hose

Consult your local KUBOTA Dealer for this service.

3. Replacing DPF related rubber pipe

Consult your local KUBOTA Dealer for this service.

4. Replacing EGR cooler hose

Consult your local KUBOTA Dealer for this service.

5. Cleaning master cylinder filter

Consult your local KUBOTA Dealer for this service.

EVERY 3 YEARS

1. Replacing cables of both parking brakes

Consult your local KUBOTA Dealer for this service.

EVERY 4 YEARS

1. Replacing radiator hose (water pipes)

Replace the hoses and clamps.
(See Checking radiator hose and clamp on page 127.)

2. Replacing fuel lines

Consult your local KUBOTA Dealer for this service.

3. Replacing intake air line

Consult your local KUBOTA Dealer for this service.

4. Replacing power steering line

Consult your local KUBOTA Dealer for this service.

5. Replacing lift cylinder hose

Consult your local KUBOTA Dealer for this service.

6. Replacing master cylinder kit

Consult your local KUBOTA Dealer for this service.

7. Replacing brake seal 1 and 2

Consult your local KUBOTA Dealer for this service.

8. Replacing air conditioner hose

Consult your local KUBOTA Dealer for this service.

SERVICE AS REQUIRED

1. Bleeding fuel system

Air must be removed:

- When the fuel filter or lines are removed.
- When the water is drained from the water separator.
- When the tank is completely empty.
- After the tractor has not been used for a long period of time.

Bleeding procedure is as follows:

1. Fill the fuel tank with fuel, and open the fuel shutoff-valve.

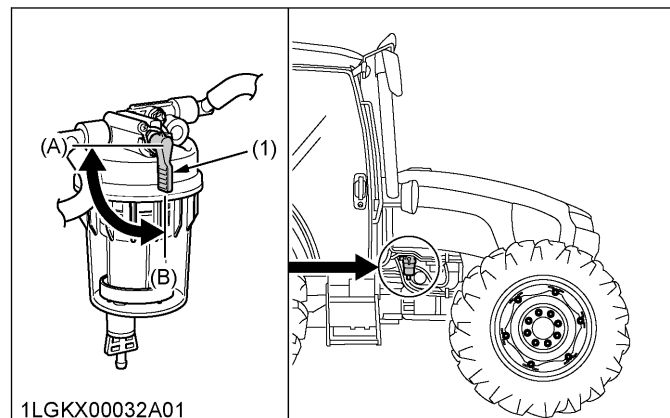

1LGKX00032A01
(1) Fuel shutoff-valve

(A) "CLOSE"
(B) "OPEN"

2. Disconnect the heater connector.

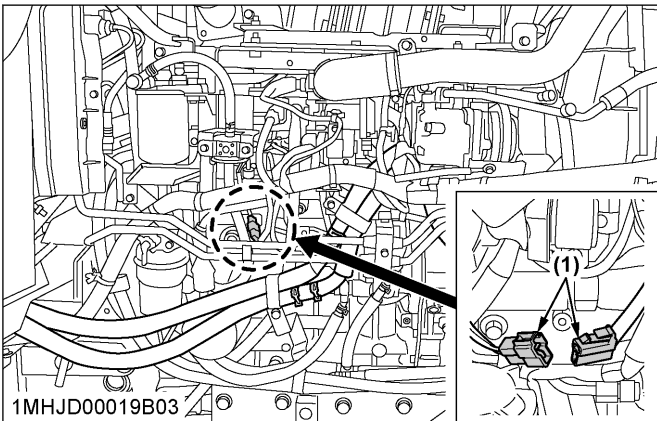

(1) Connector

IMPORTANT :

- Do not try air-bleeding with the heater in operation. Otherwise the battery may be damaged.

3. Turn "ON" and "OFF" the key switch repeatedly 10 times or so at the following intervals. This lets the air out of the fuel line.

- Key switch "ON" time: 30 seconds
- Key switch "OFF" time: 15 seconds

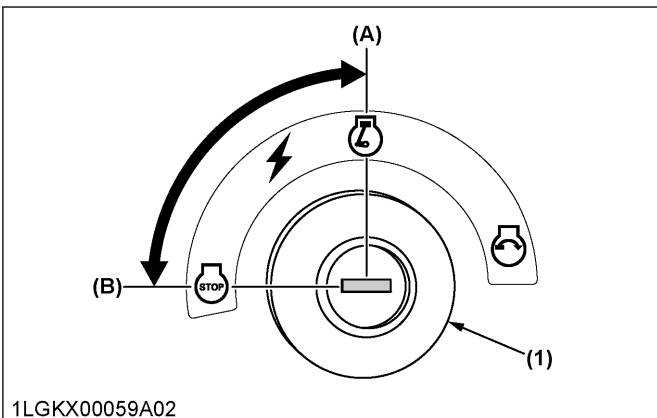

(1) Key switch

(A) "ON"
(B) "OFF"

4. Connect the heater connector.
5. Set the hand throttle lever at the maximum speed position, turn the key switch to start the engine and then reset the throttle lever at the mid speed (around 1500 rpm) position.
If the engine does not start, try it several times at 30 second intervals.

IMPORTANT :

- Do not hold the key switch at the engine start position for more than 10 seconds continuously. If more engine cranking is needed, try again after 30 seconds.

6. Accelerate the engine to remove the small portion of air left in the fuel system.

7. If air still remains and the engine stops, repeat the previous steps.

2. Bleeding brake system

Consult your local KUBOTA Dealer for this service.

3. Draining clutch housing water

The tractor is equipped with a drain plug under the clutch housing.
After operating in the rain or snow, or if the tractor has been washed, water may get into the clutch housing.
Remove the drain plug, drain the water and then reinstall the plug.

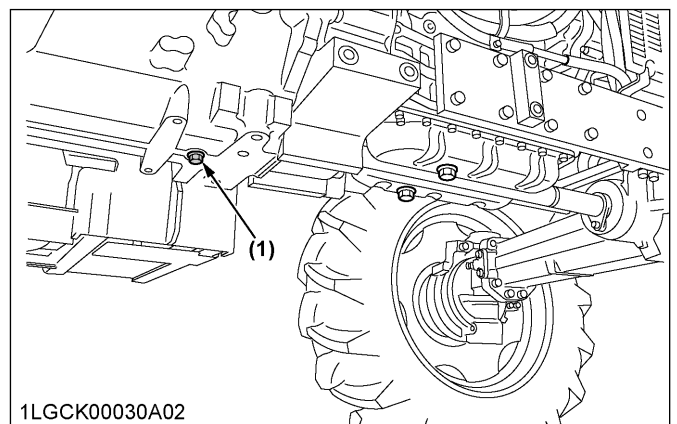

(1) Water drain plug

4. Replacing fuses

The tractor electrical system is protected from potential damage by fuses.
A blown fuse indicates that there is an overload or short somewhere in the electrical system.
If any of the fuses should blow, replace with a new one of the same capacity.

IMPORTANT :

- Before replacing a blown fuse, determine why the fuse blew and make any necessary repairs. Failure to follow this procedure may result in serious damage to the tractor electrical system. For specific information dealing with electrical problems, read the troubleshooting section of this manual or contact your local KUBOTA Dealer.
(See TROUBLESHOOTING on page 141.)

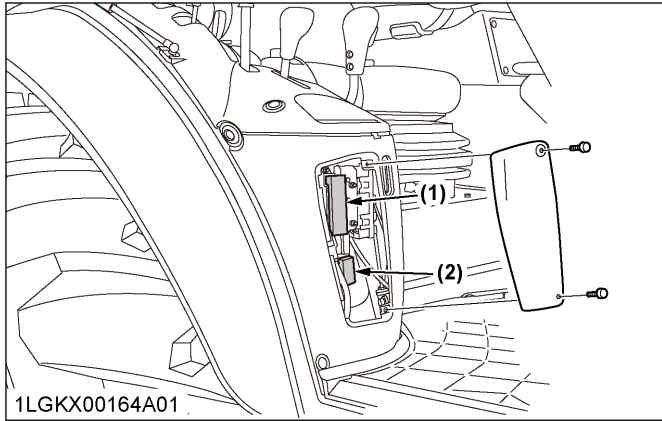

(1) Fuse box 1
(2) Fuse box 2

Fuse box 1

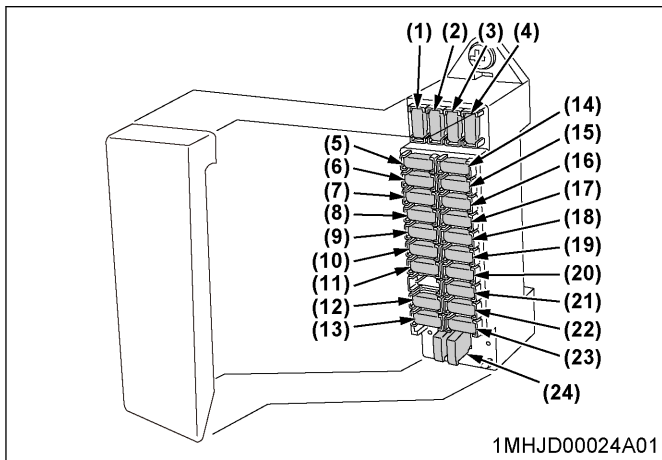

Fuse box 2

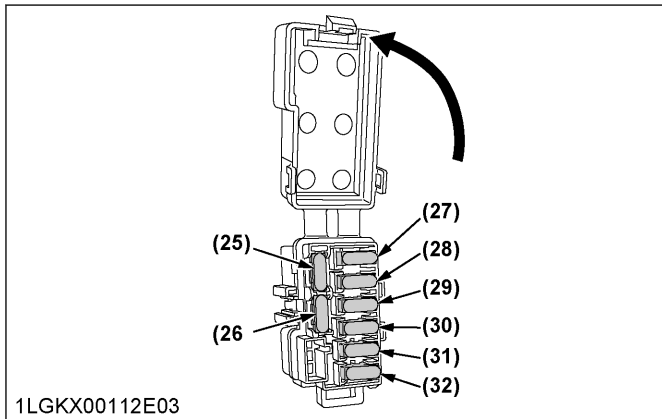

Fuse No.	Capacity	Protected circuit
(1)	20 A	Spare fuse
(2)	15 A	Spare fuse
(3)	10 A	Spare fuse
(4)	5 A	Spare fuse
(5)	15 A	Work light (rear)
(6)	15 A	Work light (front)
(7)	15 A	Cigarette lighter
(8)	30 A	Air conditioner (fan motor)
(9)	10 A	Air conditioner (compressor)
(10)	20 A	Work light (front side)
(11)	5 A	Transmission control
(12)	15 A	ECU
(13)	5 A	Starter relay
(14)	5 A	Radio
(15)	5 A	Air conditioner (control)
(16)	15 A	Wiper
(17)	10 A	Alternator, PTO, engine
(18)	5 A	Meter
(19)	10 A	Turn signal
(20)	10 A	Back up (meter)
(21)	20 A	Headlight
(22)	20 A	Flasher (hazard)
(23)	5 A	Loader (ACC)
(24)	Fuse puller	
(25)	15 A	Spare fuse
(26)	10 A	Spare fuse
(27)	5 A	Back up (ECU)
(28)	15 A	Loader (+B)
(29)	15 A	Work light (option)
(30)	15 A	Stop lamp
(31)	10 A	OBD
(32)	10 A	Trailer brake valve

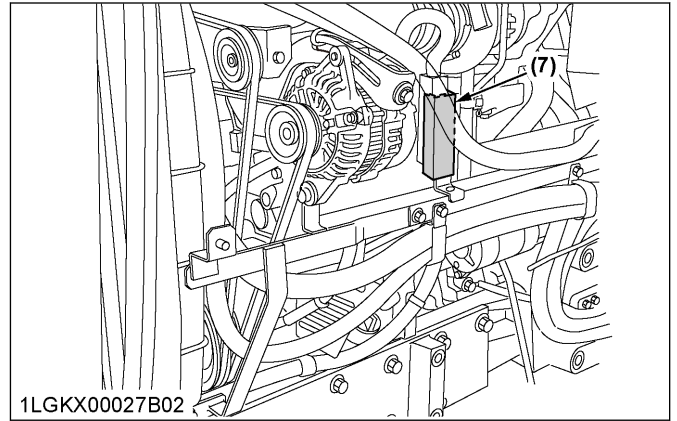
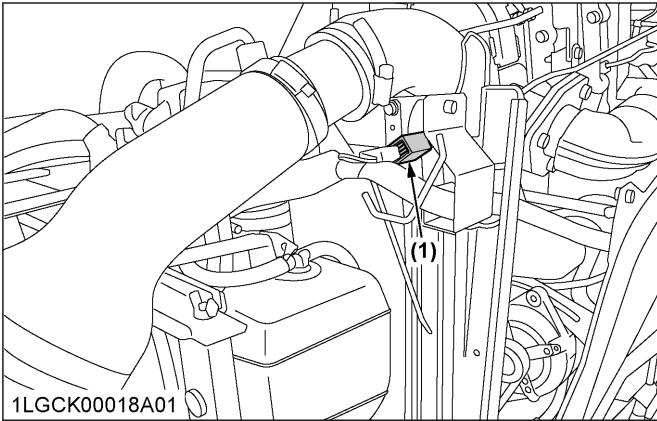

Air suspension seat (if equipped)

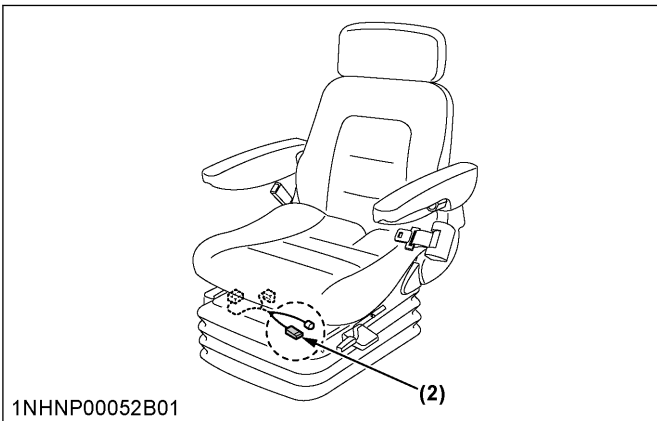

Fuse No.	Capacity	Protected circuit	Type
(1)	120 A	Engine preheat	Bolt fixed
(2)	60 A	Starter, air conditioner	
(3)	30 A	Electrical outlet	Non-bolt-fixed
(4)	40 A	Work light	
(5)	60 A	Headlight, hazard	Bolt fixed
(6)	30 A	Main key switch	
(7)	175 A	Charge	

Fuse No.	Capacity	Protected circuit
(1)	20 A	CRS system fuel pump
(2)	15 A	Air suspension (if equipped)

5. Replacing slow-blow fuses

The slow-blow fuses are intended to protect the electrical cabling. If any of them has blown out, be sure to pinpoint the cause. Never use any substitute, use only a Kubota genuine part.

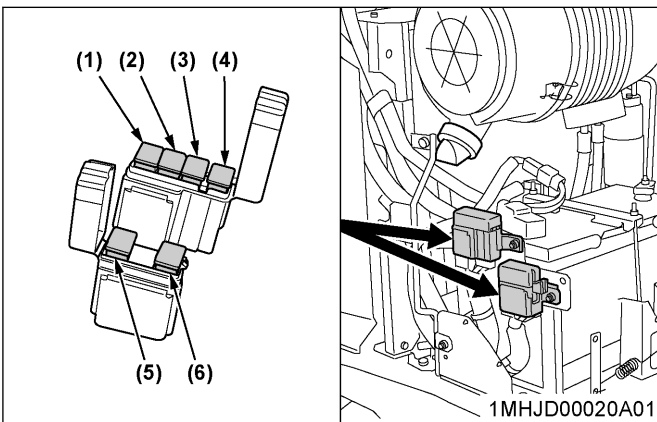

5.1 Replacement procedure

Non-bolt-fixed slow-blow fuse:

1. Disconnect the negative cord of the battery.
2. Pull out the fuse from the fuse box.
3. Replace with a new one of the same capacity.

Bolt fixed slow-blow fuse:

Consult your local KUBOTA Dealer for this service.

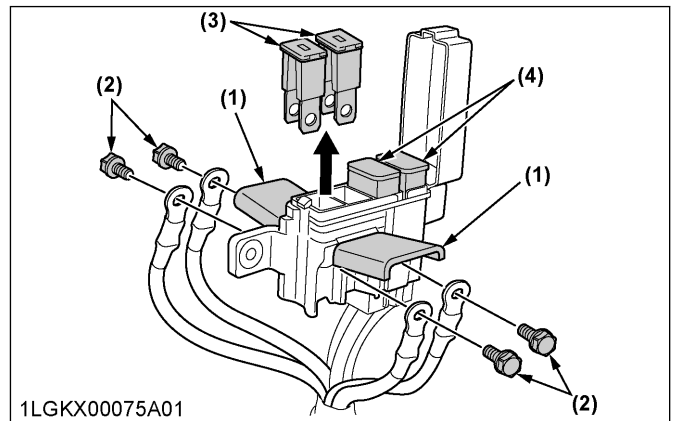

- (1) Fuse box
- (2) Bolt
- (3) Bolt fixed slow-blow fuse
- (4) Non-bolt-fixed slow-blow fuse

6. Replacing light bulb

Light	Capacity
Headlight	12 V, 60 W (HB3)
Turn signal and hazard light (front)	12 V, 21 W
Turn signal and hazard light (rear)	12 V, 21 W
Brake stop light and tail light	12 V, 21/5 W
Front work light	12 V, 35 W
Work light (for outer roof)	12 V, 55 W
Dome light (room lamp)	12 V, 5 W
Registration plate light	12 V, 10 W

7. Replacing head lamp

CAUTION

To avoid personal injury:

- Be careful not to drop the bulb, hit anything against the lamp, apply excess force, or get the lamp scratched. If broken, the glass may cause injury. Pay more attention to halogen lamps in particular, which have high pressure inside.
- Before replacing the lamp, be sure to turn off the light and wait until the bulb cools down; otherwise, you may get burned.

1. While pushing the right and left lock buttons, pull and remove the electrical connector.
2. Turn the cover counterclockwise to remove it.
3. Turn the bulb base counterclockwise to take out the bulb.
4. Replace it with a new bulb and reinstall the head lamp assembly in the reverse order.

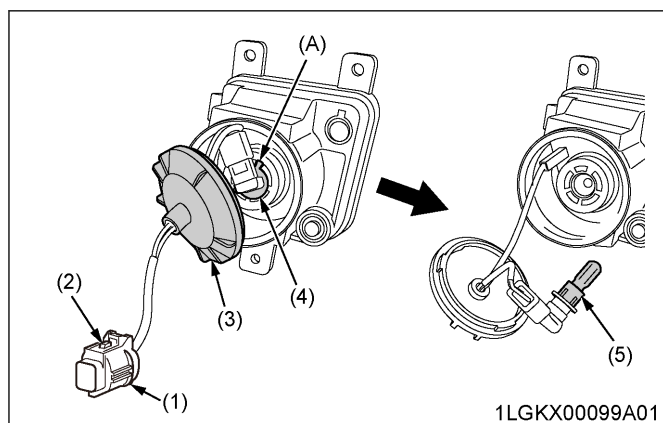

- (1) Electrical connector (A) "Base's wider projection to face upward"
- (2) Lock buttons
- (3) Cover
- (4) Bulb base
- (5) Bulb

IMPORTANT :

- Be sure to use a new bulb of the specified wattage.
- Never touch the bulb surface (glass) with bare hands. Fingerprints, for example, may break the bulb.

8. Lubricating points for door and window

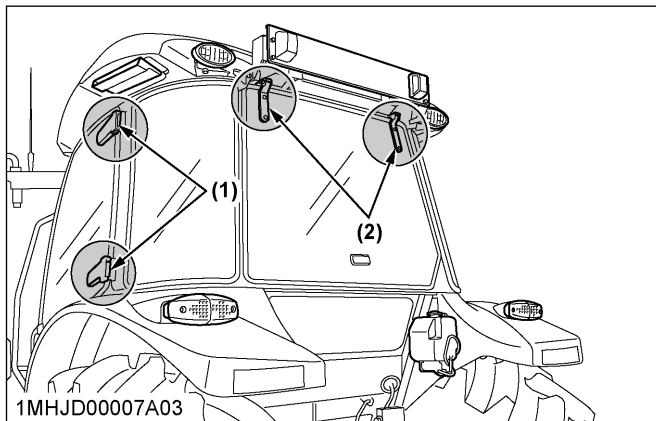

- (1) Door hinge
- (2) Rear window hinge

9. Adding washer liquid

Add a proper amount of automobile washer liquid.

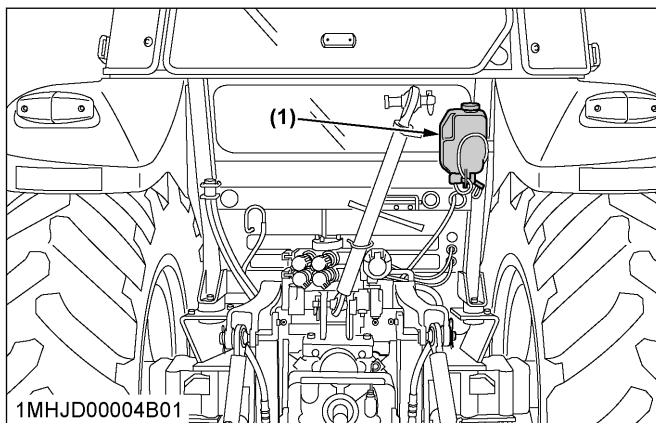

- (1) Washer liquid tank

Washer tank capacity	1.3 L
----------------------	-------

10. Checking amount of refrigerant (gas)

WARNING

To avoid personal injury or death:

- Liquid contact with eyes or skin may cause frostbite.

- In the event of a leakage, wear safety goggles. Escaping refrigerant can cause severe injuries to eyes.
- In contact with a flame, R134a refrigerant produces a toxic gas.
- Do not disconnect any part of the refrigeration circuit of the air conditioning system. Consult your local KUBOTA Dealer for assistance and service.

A shortage of refrigerant impairs the air conditioner performance. Check the following points. If it is indicated that the amount of refrigerant is extremely low, ask your dealer to inspect and refill.

Checking procedure

1. Run the air conditioner in the following conditions.
 - Engine speed - About 1500 rpm
 - Temperature control dial - Maximum cooling position
 - Fan switch - Highest blow
 - Air conditioner switch - "ON"
2. Look into the sight glass to see if and how the refrigerant is flowing through its circuit.

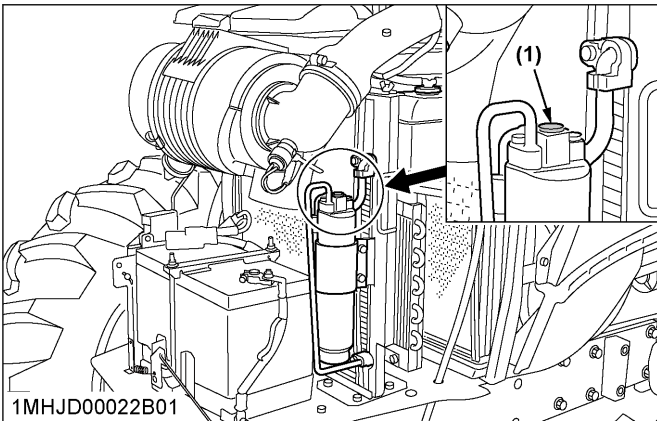

(1) Sight glass

	Proper	Little or no air bubbles in the refrigerant flow.
	Low	Lots of air bubbles in the refrigerant flow (air bubbles or foam passing continuously).
	Overfull or no refrigerant:	Colorless and transparent.

IMPORTANT :

- Charge only with R134a, not R12 refrigerant.

STORAGE



WARNING

To avoid personal injury or death:

- Do not clean the machine while the engine is running.
- To avoid the danger of exhaust fume poisoning, do not operate the engine indoors without proper ventilation.
- When storing, remove the key from the key switch to prevent unauthorized persons from operating the tractor and getting injured.

TRACTOR STORAGE

If you intend to store your tractor for an extended period of time, follow the procedures outlined below.

These procedures will ensure that the tractor is ready to operate with minimum preparation when it is removed from storage.

1. Check the bolts and nuts for looseness and tighten if necessary.
2. Apply grease to tractor areas where bare metal will rust, and also to pivot areas.
3. Detach the weights from the tractor body.
4. Inflate the tires to a pressure a little higher than usual.
5. Change the engine oil and run the engine to circulate oil throughout the engine block and internal moving parts for about 5 minutes.
6. Keep the PTO clutch control switch or lever at "DISENGAGE" position while the tractor is stored for a long period of time.
7. With all implements lowered to the ground, coat any exposed hydraulic cylinder piston rods with grease.
8. Remove the battery from the tractor. Store the battery following the battery storage procedures. (See Checking battery condition on page 121.)
9. Keep the tractor in a dry place where the tractor is sheltered from the elements. Cover the tractor.
10. Store the tractor indoors in a dry area that is protected from sunlight and excessive heat.
If the tractor must be stored outdoors, cover it with a waterproof tarpaulin.
Jack the tractor up and place blocks under the front and rear axles so that all 4 tires are off the ground. Keep the tires out of direct sunlight and extreme heat.

IMPORTANT :

- When washing the tractor, be sure to stop the engine. Allow sufficient time for the engine to cool down before washing.
- Cover the tractor after the muffler and the engine have cooled down.

REMOVING THE TRACTOR FROM STORAGE

1. Check the tire air pressure and inflate the tires if needed.
2. Jack the tractor up and remove the support blocks from under the front and rear axles.
3. Install the battery. Before installing the battery, be sure it is fully charged.
4. Check the fan belt tension.
5. Check all fluid levels (engine oil, transmission and hydraulic oil, engine coolant, and any attached implements).
6. Start the engine. Observe all gauges.
If all the gauges are functioning properly and have normal readings, move the tractor outside.
Once outside, park the tractor and let the engine idle for at least 5 minutes. Shut the engine off and walk around the tractor and make a visual inspection looking for evidence of oil or water leaks.
7. With the engine fully warmed up, release both parking brakes and test the brakes for proper adjustment as you move forward. Adjust the brakes as necessary.

TROUBLESHOOTING

ENGINE TROUBLESHOOTING

If something is wrong with the engine, refer to the following table for the cause and its corrective measure.

Trouble		Cause	Countermeasure
Engine is difficult to start or will not start.		<ul style="list-style-type: none"> No fuel flow. 	<ul style="list-style-type: none"> Check the fuel tank and the fuel filter. Replace filter if necessary.
		<ul style="list-style-type: none"> Air or water is in the fuel system. 	<ul style="list-style-type: none"> Check to see if the fuel line coupler bolt and nut are tight. Bleed the fuel system (See Bleeding fuel system on page 134.)
		<ul style="list-style-type: none"> In winter, oil viscosity increases, and engine revolution is slow. 	<ul style="list-style-type: none"> Use oils of different viscosities, depending on ambient temperatures. Use engine block heater (optional).
		<ul style="list-style-type: none"> Battery becomes weak and the engine does not turn over quick enough. 	<ul style="list-style-type: none"> Clean battery cables and terminals. Charge the battery. In cold weather, always remove the battery from the engine, charge and store it indoors. Install it on the tractor only when the tractor is going to be used.
		<ul style="list-style-type: none"> Intake air heater system trouble. 	<ul style="list-style-type: none"> Check to see if the slow blow fuse of the intake air heater blows. Check to see if the intake air heater functions in cold weather.
Insufficient engine power.		<ul style="list-style-type: none"> Insufficient or dirty fuel. The air cleaner is clogged. 	<ul style="list-style-type: none"> Check the fuel system. Clean or replace the element.
Engine stops suddenly.		<ul style="list-style-type: none"> Insufficient fuel. 	<ul style="list-style-type: none"> Refuel. Bleed the fuel system if necessary.
Exhaust fumes are colored.	Black	<ul style="list-style-type: none"> Fuel quality is poor. Too much oil. The air cleaner is clogged. 	<ul style="list-style-type: none"> Change the fuel and fuel filter. Drain excess oil if necessary. Clean or replace the element.
	Blue white	<ul style="list-style-type: none"> The inside of the exhaust muffler is damp with fuel. Injection nozzle trouble. Fuel quality is poor. 	<ul style="list-style-type: none"> Check to see if the intake air heater functions in cold weather. Heat the muffler by applying load to the engine. Check the injection nozzle. Change the fuel and fuel filter.
Engine overheats.		<ul style="list-style-type: none"> Engine overloaded. 	<ul style="list-style-type: none"> Shift to lower gear or reduce load.
		<ul style="list-style-type: none"> Low coolant level. 	<ul style="list-style-type: none"> Fill cooling system to the correct level; check radiator and hoses for loose connections or leaks.
		<ul style="list-style-type: none"> Loose or defective fan belt. 	<ul style="list-style-type: none"> Adjust or replace fan belt.
		<ul style="list-style-type: none"> Dirty radiator core or grille screens. 	<ul style="list-style-type: none"> Remove all trash.
		<ul style="list-style-type: none"> Coolant flow route corroded. 	<ul style="list-style-type: none"> Flush cooling system.

If you have any questions, contact your local KUBOTA Dealer.

Trouble	Operator's action
Engine not overheated, but engine warning indicator on.	<p>Stop the engine and get it restarted. If the engine fails to restart or the indicator stays on, immediately contact your local KUBOTA Dealer. If the warning indicator lights up, the following phenomena may appear depending on the engine's trouble spot.</p> <ul style="list-style-type: none"> The engine stops unexpected. The engine fails to start or gets interrupted just after start. The engine output is not enough. The engine output is enough, but the warning indicator stays on.

If you have any questions, contact your local KUBOTA Dealer.

POWERTRAIN TROUBLESHOOTING

If something is wrong with the powertrain, the master system warning indicator starts blinking, and the error code shown in the following table is displayed on the LCD. The error code indicates the location of the trouble. If an error code appears, immediately contact your local KUBOTA Dealer for repairs.

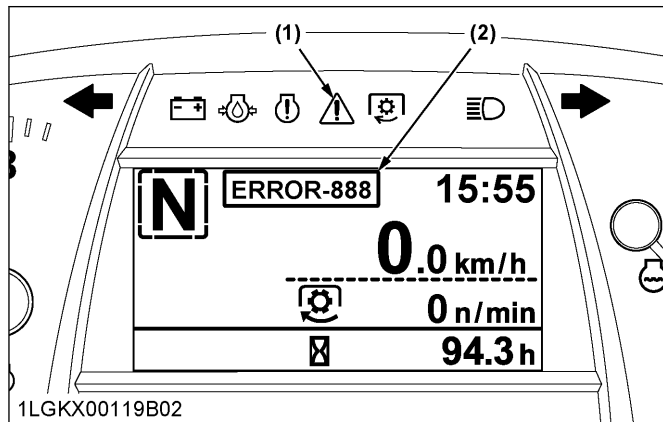

(1) Master system warning indicator

(2) Error code

Displayed error code (DBM)	Trouble
[ERROR-1]	Throttle sensor (main) trouble
[ERROR-2]	Throttle sensor (sub) trouble
[ERROR-3]	Throttle sensor phase shifting trouble
[ERROR-4]	Shuttle sensor (main) trouble
[ERROR-5]	Shuttle sensor (sub) trouble
[ERROR-6]	Shuttle sensor phase shifting trouble
[ERROR-7]	Shuttle sensor signal trouble
[ERROR-8]	Parking brake switch signal error
[ERROR-11]	Rear PTO solenoid valve
[ERROR-12]	4WD solenoid valve trouble
[ERROR-14]	Shuttle forward solenoid valve trouble
[ERROR-15]	Shuttle reverse solenoid valve trouble
[ERROR-17]	Differential lock solenoid valve trouble
[ERROR-21]	Range gear shift high switch trouble
[ERROR-22]	Main gear shift 6th switch trouble
[ERROR-23]	Shuttle revolution sensor signal error
[ERROR-24]	Travel speed revolution sensor signal error
[ERROR-ENG] [(ERROR-41)]	CAN communication error (engine)
[ERROR-ECU] [(ERROR-43)]	CAN communication error (DBM)
[ERROR-60]	Sensor supply error
[ERROR-63]	Accelerator adjustment error
[ERROR-NET]	Communication trouble

OPTIONS

LIST OF OPTIONS

Consult your local KUBOTA Dealer for further details.

- Instructional seat
- Room mirror
- Double acting remote hydraulic control valve with detents and self-canceling
- Double acting remote hydraulic control valve with float position
- Remote control valve lever kit
- Flow control valve kit
- Air suspension seat kit
- Quick hitch lower link kit
- Work light kit
- 540/1000 switchable PTO

INDEX

Symbols

3-point hitch.....	78
lowering speed knob.....	86
starting.....	79
using.....	11
3-point hitch control system.....	85
4WD braking system.....	55
4WD switch.....	60
4WD wheels tread (front) adjusting.....	92

A

aftertreatment devices.....	36
air cleaner primary element cleaning.....	119
replacing.....	131
air cleaner secondary element replacing.....	131
air conditioner cooling.....	102
defrosting or demisting.....	102
dehumidifying-heating.....	102
heating.....	101
air conditioner belt adjusting tension.....	122
air conditioner condenser cleaning.....	113,114
air conditioner condenser assembly sliding.....	114
air conditioner hose checking.....	130
replacing.....	134
air conditioner pipe checking.....	130
air conditioner switch.....	101
air control vent.....	100
air suspension seat (if equipped).....	50
airflow.....	99
antifreeze using.....	132

B

battery charging.....	122
checking condition.....	121
checking condition by reading indicator.....	121
battery mount cleaning.....	113,114
battery storage directions.....	122
beacon light.....	103
before operating the tractor.....	7
block heater (if equipped).....	46

blower switch (air conditioner).....	101
boost sensor hose replacing.....	134
brake pedal adjusting.....	120
checking.....	115
checking equalizer working level (anti-imbalance device).....	120
checking free travel.....	120
checking stroke.....	120
brake pedals (right and left).....	54
brake seal 1 and 2 replacing.....	134
brake system bleeding.....	135
braking system (4WD).....	55
breather related rubber pipe replacing.....	134

C

CAB classification.....	96
CAB isolation cushion checking.....	133
CAB maintenance.....	96
cables of both parking brakes replacing.....	134
clock setting.....	64
clock display setting ON/OFF.....	65
clutch housing water draining.....	135
clutch pedal.....	55
clutch-off switch (if equipped).....	59
constant RPM Management control.....	70
control panel (air conditioner).....	100
coolant.....	108
changing.....	131
checking level.....	113
coolant temperature gauge.....	63
cooling system changing coolant.....	131
flushing.....	131
creep speed.....	58

D

daily check.....	35,111
attaching and detaching panel.....	114
checking brake pedal.....	115
checking coolant level.....	113
checking DPF muffler.....	114
checking Easy Checker.....	115
checking engine oil level.....	112

checking fuel gauge.....	111
checking gauges.....	115
checking hazard light.....	116
checking headlight.....	116
checking meter.....	115
checking movable parts.....	116
checking parking brake.....	115
checking seat belt.....	116
checking transmission fluid level.....	112
checking turn signal light.....	116
checking water separator.....	112
checking gear-locked parking brake.....	115
cleaning.....	114
cleaning air conditioner condenser.....	113,114
cleaning battery mount.....	113,114
cleaning evacuator valve.....	113
cleaning fuel cooler.....	113,114
cleaning grill.....	113,114
cleaning oil cooler.....	113,114
cleaning radiator screen.....	113,114
refueling.....	111
walking around inspection.....	111
warning.....	111
diesel particulate filter (DPF) muffler.....	36
differential lock.....	72
dome light.....	97
door	
locking and unlocking.....	96
lubricating points.....	138
opening.....	96
DPF auto regeneration mode.....	39
operating procedure.....	38
DPF muffler.....	36
checking.....	114
cleaning.....	133
handling points.....	36
DPF parked regeneration mode	
operating procedure.....	42
DPF regeneration	
tips.....	43
DPF regeneration inhibit mode.....	41
operating procedure.....	40
DPF regeneration process.....	37
DPF related pipe	
checking.....	133
DPF related rubber pipe	
replacing.....	134
draft control.....	85
drawbar.....	78,83
adjusting length.....	83
removing.....	80
dual speed shift switch (if equipped).....	59
dual tires.....	91

E

Easy Checker	
checking.....	115

Easy Checker indicator	
checking.....	45
Easy Checker indicators.....	61
EGR cooler	
checking.....	131
EGR cooler hose	
replacing.....	134
EGR pipe	
checking.....	134
EGR system	
checking.....	133
cleaning.....	133
electrical outlet.....	103
electrical outlet for trailer.....	74
electronic engine control.....	69
emergency exit.....	97
engine	
jump starting.....	46
operating in freezing conditions.....	46
overheating.....	128
starting.....	43
stopping.....	46
stopping immediately.....	61
troubleshooting.....	141
warming up.....	46
warming up at low temperature range.....	46
engine oil	
changing.....	116,125
checking level.....	112
engine oil filter	
replacing.....	116,125
engine over-speed limiting indicator.....	61
engine start system	
checking.....	116
checking operator presence control (OPC) system..	
.....	117
preparation before testing.....	116
testing switch for PTO clutch control switch.....	116
testing switch for shuttle shift lever.....	116
engine valve clearance	
adjusting.....	131
evacuator valve	
cleaning.....	113
exhaust aftertreatment devices.....	36
exhaust manifold	
checking.....	131

F

fan belt tension	
adjusting.....	119
float control.....	86
flow control valve (option).....	88
flow control valve advantages.....	88
flow control valve positions.....	88
flow rate	
adjusting.....	88
fluorinated greenhouse gases.....	138

foot controls.....	34
foot throttle.....	60
fresh air filter	
cleaning.....	124
removing.....	124
front axle gear case oil	
changing.....	131
front axle pivot	
adjusting.....	130
front differential case oil	
changing.....	130
front jack point.....	93
front wheels tread (4WD)	
adjusting.....	92
front wiper and washer switch.....	99
front work light.....	98
front-wheel drive (4WD).....	60
fuel.....	108
fuel cooler	
cleaning.....	113,114
fuel filter	
replacing.....	126
fuel gauge.....	62
fuel injector nozzle tip	
cleaning.....	131
fuel lines	
checking.....	128
replacing.....	134
fuel system	
bleeding.....	134
fuel tank water	
draining.....	123
fuse	
replacing.....	135
G	
gauge	
checking.....	115
gear-locked parking brake	
checking.....	115
gear-locked parking brake lever.....	55
grease fittings	
lubricating.....	117
grill	
cleaning.....	113,114
H	
hand controls.....	32,34
hand throttle lever.....	60
hazard and turn signal indicator.....	53,54
hazard light	
checking.....	116
hazard light switch.....	53
head lamp	
replacing.....	138
headlight	
checking.....	116

hood.....	110
horn button.....	54
hydraulic control unit	
reference chart.....	90
hydraulic oil filter	
replacing.....	126

I

implement	
attaching to tractor.....	82
detaching from tractor.....	83
installing ball-joint.....	82
implement control box	
installing.....	103
implement limitations.....	27
indicator (hazard and turn signal).....	54
indicator (trailer).....	54
inner air filter	
cleaning.....	123
instructional seat (if equipped).....	9
instructional seat precautions.....	51
instrument panel.....	33
intake air heater	
checking.....	133
intake air line	
checking.....	128
replacing.....	134

J

jack point (front).....	93
jack point (rear).....	95

L

lateral float	
adjusting.....	79
LCD monitor.....	63
lift cylinder hose	
checking.....	129
replacing.....	134
lifting rod (left).....	80
lifting rod (right).....	80
light bulb	
replacing.....	138
light switch.....	53
lower link	
adjusting width.....	82
selecting holes.....	79
lower link (telescopic).....	81
lubricants.....	108
lubricating oil	
changing.....	48
lubricating points (door).....	138
lubricating points (window).....	138

M

main gear shift lever.....	58
maintenance intervals.....	105
maintenance items chart.....	106
master cylinder filter	
cleaning.....	134
master cylinder kit	
replacing.....	134
mechanical suspension seat.....	49
meter	
checking.....	115
mixed control.....	85
mode switch (air conditioner).....	100
movable parts	
checking.....	116

O

oil cooler	
cleaning.....	113,114
operator presence control (OPC) system	
checking.....	117
operator's seat.....	49
options	
list.....	143
overheating countermeasures.....	128

P

panel	
attaching and detaching.....	114
parking brake	
checking.....	115
parking brake (gear-locked)	
checking.....	120
parking brake lever.....	55
adjusting.....	121
performance monitor.....	68
PM warning level (DPF auto regeneration mode).....	39
PM warning level (DPF regeneration inhibit mode).....	41
position control.....	85
power steering	
directions for use.....	74
power steering line	
checking.....	127
replacing.....	134
powertrain	
troubleshooting.....	142
PTO	
operating.....	10,75
PTO (540/540E rpm model).....	76
PTO 540/1000 rpm model.....	77
PTO clutch control switch.....	75
PTO clutch control switch lever	
testing.....	116
PTO clutch indicator.....	75
PTO gear shift lever.....	76
PTO models.....	76

PTO rpm display.....	76
PTO shaft 1000 rpm (540/1000 rpm model)	
interchanging.....	77
PTO shaft cap.....	76
PTO shaft cover.....	76
PTO speed display	
setting.....	66
PTO speed limiter.....	77

Q

quick hitch	
hook type (if equipped).....	81

R

radiator clamp	
checking.....	127
radiator hose	
checking.....	127
radiator hose (water pipes)	
replacing.....	134
radiator screen	
cleaning.....	113,114
range gear shift lever.....	58
rear jack point.....	95
rear wheels tread	
adjusting.....	94
rear window.....	97
rear wiper and washer switch.....	99
rear work light.....	98
recirculation or fresh air selection switch.....	101
refrigerant (gas) amount	
checking.....	138
remote control valve.....	86
remote control valve coupler	
connecting.....	87
disconnecting.....	87
remote control valve lever.....	87
remote hydraulic control system.....	86
RPM dual memory	
setting.....	69

S

safety	
CAB and ROPS.....	7
driving tractor on the road.....	9
general information.....	7
instructional seat (if equipped).....	9
operating PTO.....	10
operating tractor.....	8
operating tractor on slopes.....	9
parking tractor.....	10
safety labels.....	14
servicing tractor.....	11
starting to operate tractor.....	8
transporting tractor.....	74
using 3-point hitch.....	11

working tractor.....	8
safety for children.....	9
safety labels.....	14
taking care of the labels	19
seat belt.....	50
checking.....	116
seat for passenger (if equipped).....	50
service intervals.....	105
shift lever (main gear).....	58
shift lever (PTO gear).....	76
shift lever (range gear).....	58
shift lever (shuttle).....	58
shuttle shift lever.....	58
shuttle shift lever switch	
testing.....	116
side cover.....	110
side window.....	97
slow-blow fuse	
replacement procedure.....	137
replacing.....	137
specification table (implement).....	28
specification table (tractor).....	23
sunroof.....	97
supply pump	
checking.....	133
swing drawbar.....	84
switches.....	32

T

tachometer.....	63
telescopic stabilizers.....	81
temperature control dial (air conditioner).....	101
tie-rod dust cover	
checking.....	117
tilt steering	
adjusting.....	52
tire circumference	
setting.....	65
tire size and inflation pressure.....	91
tires.....	91
toe-in	
adjusting.....	123
adjusting procedure.....	123
top link.....	80
selecting mounting holes.....	79
tractor	
before operating.....	7
boarding.....	48
detaching implement.....	83
driving on the road.....	9
leaving.....	48
operating.....	8
operating on a road.....	73
operating on slopes.....	9
operating on slopes and rough terrain.....	73
operating techniques.....	72
parking.....	10,71

removing from storage.....	140
scrapping procedure.....	22
servicing.....	11
starting.....	48
starting to operate.....	8
stopping.....	61
storing procedure.....	140
transporting safely.....	74
working.....	8
tractor (new)	
changing lubricating oil.....	48
operating.....	48
operating caution.....	48
tractor parts (overview).....	30
trailer connector.....	54
trailer indicator.....	54
transmission fluid	
changing.....	130
checking level.....	112
transmission fluid at low temperature range.....	46
travel speed control.....	57
travel speed limiter.....	58
travel speeds.....	25
turbocharger	
checking.....	133
turn signal light	
checking.....	116
turn signal light switch.....	53

U

unit	
setting.....	66

V

various setting mode.....	64
---------------------------	----

W

warranty.....	22
washer liquid	
adding.....	138
waste disposal.....	110
water separator	
checking.....	112
cleaning.....	124
wheel	
adjusting.....	91
wheel bolt torque	
checking.....	117
wheels tread (4WD, front)	
adjusting.....	92
wheels tread (rear)	
adjusting.....	94
window	
lubricating points.....	138
window (rear).....	97
window (side).....	97

wiper and washer switch (front).....	99
wiper and washer switch (rear).....	99
wipers	
using in cold season.....	99
work light.....	98
work light (front).....	98
work light (rear).....	98
work light switch.....	98