



- U.S.A. : **KUBOTA TRACTOR CORPORATION**
3401 Del Amo Blvd., Torrance, CA 90503, U.S.A.
Telephone : (310)370-3370
- Western Division : 1175 S. Guild Av., Lodi, CA 95240
Telephone : (209)334-9910
- Central Division : 14855 FAA Blvd., Fort Worth, TX 76155
Telephone : (817)571-0900
- Northern Division : 6300 at One Kubota Way, Groveport, OH 43125
Telephone : (614)835-1100
- Southeast Division : 1025 Northbrook Parkway, Suwanee, GA 30024
Telephone : (770)995-8855
- Canada : **KUBOTA CANADA LTD.**
5900 14th Avenue, Markham, Ontario, L3S 4K4, Canada
Telephone : (905)294-7477
- France : **KUBOTA EUROPE S.A.S**
19-25, Rue Jules Vercey, Z.I. BP88, 95101 Argenteuil Cedex, France
Telephone : (33)1-3426-3434
- Italy : **KUBOTA EUROPE S.A.S Italy Branch**
Via Grandi, 29 20068 Peschiera Borrome (MI) Italy
Telephone : (39)02-51650377
- Germany : **KUBOTA (DEUTSCHLAND) GmbH**
Senefelder Str. 3-5 63110 Rodgau /Nieder-Roden, Germany
Telephone : (49)6106-873-0
- U.K. : **KUBOTA (U.K.) LTD.**
Dormer Road, Thame, Oxfordshire, OX9 3UN, U.K.
Telephone : (44)1844-214500
- Spain : **KUBOTA ESPAÑA S.A.**
Avenida Recomba No.5, Poligono Industrial la Laguna, Leganes, 28914 (Madrid) Spain
Telephone : (34)91-508-6442
- Australia : **KUBOTA TRACTOR AUSTRALIA PTY LTD.**
25-29 Permas Way, Truganina, VIC 3029, Australia
Telephone : (61)-3-9394-4400
- Malaysia : **SIME KUBOTA SDN. BHD.**
No.3 Jalan Sepadu 25/123 Taman Perindustrian Axis,
Seksyen 25, 40400 Shah Alam, Selangor Darul Ehsan Malaysia
Telephone : (60)3-736-1388
- Philippines : **KUBOTA PHILIPPINES, INC.**
232 Quirino Highway, Baesa, Quezon City 1106, Philippines
Telephone : (63)2-422-3500
- Taiwan : **SHIN TAIWAN AGRICULTURAL MACHINERY CO., LTD.**
16, Fengping 2nd Rd, Taliaw Shiang Kaohsiung 83107, Taiwan R.O.C.
Telephone : (886)7-702-2333
- Indonesia : **PT KUBOTA MACHINERY INDONESIA**
Tower A at EightyEight@Kasablanka Lantai 16
Jalan Raya Casablanka Kav. 88, Jakarta 12870 Indonesia
Telephone : (62)-21-29568-720
- Thailand : **SIAM KUBOTA CORPORATION CO., LTD.**
101/19-24 Moo 20, Navanakorn Industrial Estate, Tambon Khlongnueng, Amphur Khlongluang,
Pathumthani 12120, THAILAND
Telephone : (66)2-909-0300
- Korea : **KUBOTA KOREA CO., LTD.**
41-27, Jayumuyeok-gil, Baeksan-myeon, Gimje-si, Jeollabuk-do, Korea
Telephone : (82)-63-544-5822
- India : **KUBOTA AGRICULTURAL MACHINERY INDIA PVT. LTD.**
Regus, Level 2 Altius, Olympia Tech Park, No.1 SIDCO Industrial Estate, Guindy, Chennai 600032, TN, India
Telephone : (91)-44-4299-4237
- Vietnam : **KUBOTA VIETNAM CO., LTD.**
Lot B-3A2-CN, My Phuoc 3 Industrial Park, Ben Cat District, Binh Duong Province, Vietnam
Telephone : (84)-650-3577-507

KUBOTA Corporation

English (Australia)
Code No. 3C363-9971-1

M
7
0
4
0
S
U
H
D

OPERATOR'S MANUAL

KUBOTA TRACTOR

MODEL M7040SUHD

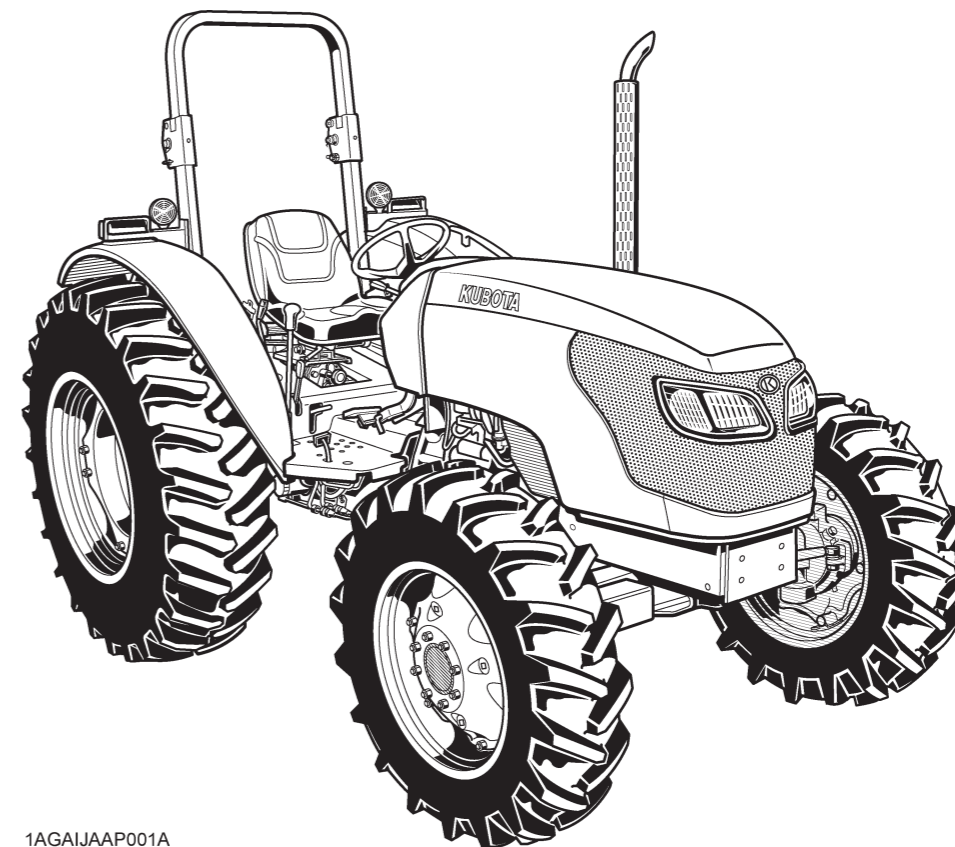

1AGAIJAP001A

FOREWORD

Thank you very much for choosing the M series tractor.

This operator's manual covers the operation, inspection and preventive maintenance instructions that is specific to the oceania models. For other information and instructions, refer to the separately issued operator's manual for the sister models. (M7040SUHD)

Please read both manuals carefully, to operate the machine properly and safety.

Proper daily inspection, servicing and lubrication keeps your machine in good condition.

KUBOTA Corporation is ...

Since its inception in 1890, KUBOTA Corporation has grown to rank as one of the major firms in Japan.

To achieve this status, the company has through the years diversified the range of its products and services to a remarkable extent, until today, 19 plants and 16,000 employees produce over 1,000 different items, large and small.

All these products and all the services which accompany them, however, are unified by one central commitment. KUBOTA makes products which, taken on a national scale, are basic necessities. Products which are indispensable, products intended to help individuals and nations fulfill the potential inherent in their environment. For KUBOTA is the Basic Necessities Giant.

This potential includes water supply, food from the soil and from the sea, industrial development, architecture and construction, and transportation.

Thousands of people depend on KUBOTA's know-how, technology, experience and customer service. You too can depend on KUBOTA.

SAFETY FIRST

This symbol, the industry's "Safety Alert Symbol", is used throughout this manual and on labels on the machine itself to warn of the possibility of personal injury. Read these instructions carefully. It is essential that you read the instructions and safety regulations before you attempt to assemble or use this unit.

 **DANGER :** Indicates an imminently hazardous situation which, if not avoided, will result in death or serious injury.

 **WARNING :** Indicates a potentially hazardous situation which, if not avoided, could result in death or serious injury.

 **CAUTION :** Indicates a potentially hazardous situation which, if not avoided, could result in minor or moderate injury.

IMPORTANT : Indicates that equipment or property damage could result if instructions are not followed.

NOTE : Gives helpful information.

CONTENTS

- ▲ SAFE OPERATION ▲ -1
- SPECIFICATIONS 1
 - SPECIFICATION TABLE 1
 - TRAVELING SPEEDS 3
- INSTRUMENT PANEL AND CONTROLS 4
- OPERATING THE TRACTOR 6
 - STARTING 6
 - Turn Signal / Hazard Light Switch 6
 - Horn Button 6
- 3-POINT HITCH & DRAWBAR 7
 - DRAWBAR 7
 - Adjusting Drawbar Length 7
 - Swing Drawbar 7
- HYDRAULIC UNIT 8
 - REMOTE HYDRAULIC CONTROL SYSTEM 8
 - Remote Control Valve 8
 - Remote Control Valve Lever 8
- PERIODIC SERVICE 10
 - SERVICE AS REQUIRED 10
 - Replacing Fuse 10
 - Replacing Light Bulb 10
- OPTIONS 11



SAFE OPERATION

Careful operation is your best insurance against an accident.

Read and understand this manual carefully before operating the tractor.

All operators, no matter how much experience they may have, should read this and other related manuals before operating the tractor or any implement attached to it. It is the owner's obligation to instruct all operators in safe operation.

1. BEFORE OPERATING THE TRACTOR

1. Know your equipment and its limitations. Read this entire manual before attempting to start and operate the tractor.
2. Pay special attention to the danger, warning and caution labels on the tractor.
3. Do not operate the tractor or any implement attached to it while under the influence of alcohol, medication, controlled substances or while fatigued.
4. Before allowing other people to use your tractor, explain how to operate and have them read this manual before operation.
5. Never wear loose, torn, or bulky clothing around tractor. It may catch on moving parts or controls, leading to the risk of an accident. Use additional safety items, e.g. hard hat, safety boots or shoes, eye and hearing protection, gloves, etc., as appropriate or required.
6. Do not allow passengers to ride on any part of the tractor at anytime. The operator must remain in the tractor seat during operation.
7. Check brakes, clutch, linkage pins and other mechanical parts for improper adjustment and wear. Replace worn or damaged parts promptly. Check the tightness of all nuts and bolts regularly. (For further details, see "MAINTENANCE" section.)
8. Keep your tractor clean. Dirt, grease, and trash build up may contribute to fires and lead to personal injury.
9. Use only implements meeting the specifications listed under "IMPLEMENT LIMITATIONS" in this manual or implements approved by KUBOTA.
10. Use proper weights on the front or rear of the tractor to reduce the risk of upsets. When using the front loader, put an implement or ballast on the 3-point hitch to improve stability. Follow the safe operating procedures specified in the implement or attachment manual.
11. The narrower the tread, the greater the risk of a tractor upset. For maximum stability, adjust the wheels to the widest practical tread width for your application. (See "TIRES, WHEELS AND BALLAST" section.)
12. Do not modify the tractor. Unauthorized modification may affect the function of the tractor, which may result in personal injury.

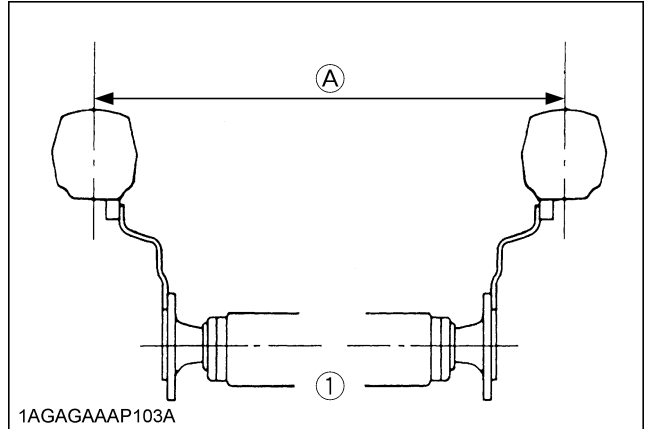

(1) Rear wheels

(A) Tread Width

◆ CAB, ROPS

1. KUBOTA recommends the use of a CAB or Roll Over Protective Structures (ROPS) and seat belt in almost all applications. This combination will reduce the risk of serious injury or death, should the tractor be upset. Check for overhead clearance which may interfere with a CAB or ROPS.
2. Set parking brake and stop engine. Remove any obstruction that may prevent raising or folding of the ROPS. Do not allow any bystanders. Always perform function from a stable position at the rear of the tractor. Hold the top of the ROPS securely when raising or folding. Make sure all pins are installed and locked.
3. If the CAB or ROPS is loosened or removed for any reason, make sure that all parts are reinstalled correctly before operating the tractor.
4. Never modify or repair any structural member of a CAB or ROPS because welding, bending, drilling, grinding, or cutting may weaken the structure.
5. A damaged CAB or ROPS structure must be replaced, not repaired or revised.
6. If any structural member of the CAB or ROPS is damaged, replace the entire structure at your local KUBOTA Dealer.

▲-2 SAFE OPERATION

7. If the tractor is equipped with a foldable ROPS it may be temporarily folded down only when absolutely necessary for areas with height constraints. (There is no operator protection provided by the ROPS in the folded position. For operator safety the ROPS should be placed in the upright and locked position and the seat belt fastened for all other operations.)
8. Always use the seat belt if the tractor has a CAB or ROPS.
Do not use the seat belt if a foldable ROPS is down or there is no ROPS. Check the seat belt regularly and replace if frayed or damaged.

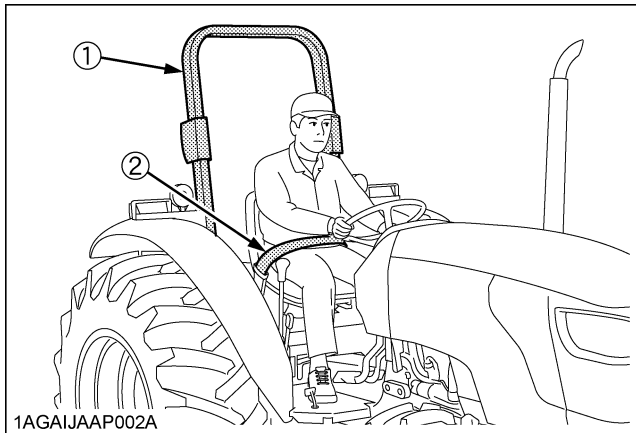

- (1) ROPS
(2) Seat belt

2. OPERATING THE TRACTOR

Operator safety is a priority. Safe operation, specifically with respect to overturning hazards, entails understanding the equipment and environmental conditions at the time of use. Some prohibited uses which can affect overturning hazards include traveling and turning with implements and loads carried too high etc. This manual sets forth some of the obvious risks, but the list is not, and cannot be, exhaustive. It is the operator's responsibility to be alert for any equipment or environmental condition that could compromise safe operation.

◆ Starting

1. Always sit in the operator's seat when starting engine or operating levers or controls. Adjust seat per instructions in the operating the tractor section. Never start engine while standing on the ground.
2. Before starting the engine, make sure that all levers (including auxiliary control levers) are in their neutral positions, that the parking brake is engaged, and that both the clutch and the Power Take-Off (PTO) are disengaged or "OFF".
Fasten the seat belt if the tractor has a CAB, a fixed ROPS or a foldable ROPS in the upright and locked position.

3. Do not start engine by shorting across starter terminals or bypassing the safety start switch. Machine may start in gear and move if normal starting circuitry is bypassed.
4. Do not operate or idle engine in a non-ventilated area. Carbon monoxide gas is colorless, odorless, and deadly.
5. Check before each use that operator presence controls are functioning correctly. Test safety systems. (See "Checking Engine Start System" in "EVERY 50 HOURS" in "PERIODIC SERVICE" section.)
Do not operate unless they are functioning correctly.

◆ Working

1. Pull only from the drawbar. Never hitch to axle housing or any other point except drawbar; such arrangements will increase the risk of serious personal injury or death due to a tractor upset.

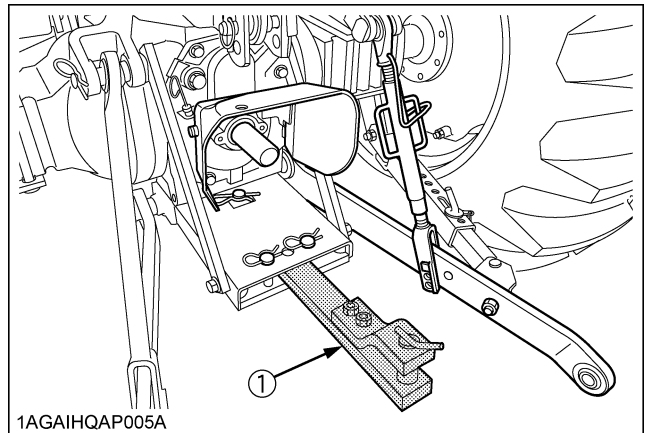

- (1) Drawbar

2. For trailing PTO-driven implements, set the drawbar to the towing position.
3. Attach pulled or towed loads to the drawbar only.
4. Keep all shields and guards in place. Replace any that are missing or damaged.
5. Avoid sudden starts. To avoid upsets, slow down when turning, on uneven ground, and before stopping.
6. The tractor cannot turn with the differential locked and attempting to do so could be dangerous.
7. Do not operate near ditches, holes, embankments, or other ground surface features which may collapse under the tractor's weight. The risk of tractor upset is even higher when the ground is loose or wet. Tall grass can hide obstacles, walk the area first to be sure.
8. Watch where you are going at all times. Watch for and avoid obstacles. Be alert at row ends, near trees, and other obstructions.
9. When working in groups, always let the others know what you are going to do before you do it.
10. Never try to get on or off a moving tractor.
11. Always sit in the operator's seat when operating levers or controls.
12. Do not stand between tractor and implement or trailed vehicle unless parking brake is applied.

◆ Safety for children

Tragedy can occur if the operator is not alert to the presence of children. Children generally are attracted to machines and the work they do.

1. Never assume that children will remain where you last saw them.
2. Keep children out of the work area and under the watchful eye of another responsible adult.
3. Be alert and shut your machine down if children enter the work area.
4. Never carry children on your machine. There is no safe place for them to ride. They may fall off and be run over or interfere with your control of the machine.
5. Never allow children to operate the machine even under adult supervision.
6. Never allow children to play on the machine or on the implement.
7. Use extra caution when backing up. Look behind and down to make sure area is clear before moving.

◆ Operating on slopes

Slopes are a major factor related to loss-of-control and tip-over accidents, which can result in severe injury or death. All slopes require extra caution.

1. To avoid upsets, always back up steep slopes. If you cannot back up the slope or if you feel uneasy on it, do not operate on it. Stay off slopes too steep for safe operation.
2. Driving forward out of a ditch, mired condition or up a steep slope increases the risk of a tractor to be upset backward. Always back out of these situations. Extra caution is required with 4-wheel drive models because their increased traction can give the operator false confidence in the tractor's ability to climb slopes.
3. Keep all movement on slopes slow and gradual. Do not make sudden changes in speed, direction or apply brake and make sudden motions of the steering wheel.
4. Avoid disengaging the clutch or changing gears speed when climbing or going down a slope. If on a slope disengaging the clutch or changing gears to neutral could cause loss of control.
5. Special attention should be made to the weight and location of implements and loads as such will affect the stability of the tractor.
6. To improve stability on slope, set widest wheel tread as shown in "TIRES, WHEELS AND BALLAST" section.
Follow recommendations for proper ballasting.
7. To avoid free wheeling:
 - Do not shift the shuttle lever while on a slope.
 - Stop completely by using the brake and by depressing the clutch pedal, then shift the shuttle lever.
 - Start off after selecting shuttle direction, by releasing the clutch pedal.

◆ Driving the tractor on the road

1. Lock the 2 brake pedals together to help assure straight-line stops. Uneven braking at road speeds could cause the tractor to tip over.

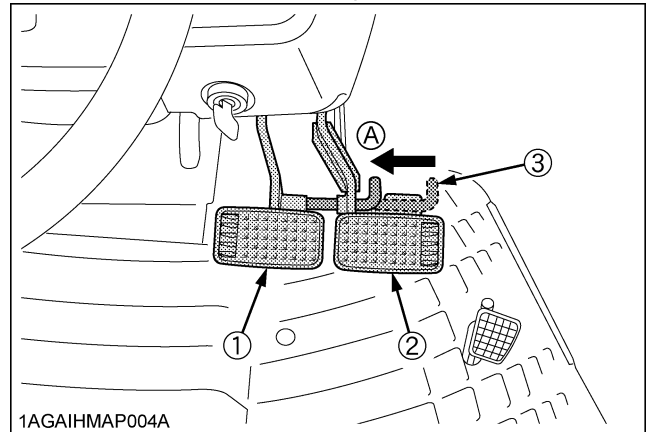

1AGAIHMAP004A

- (1) Brake Pedal (LH) (A) Whenever travelling on the road
 (2) Brake Pedal (RH)
 (3) Brake Pedal Lock

2. Check the front wheel engagement. The braking characteristics are different between 2 and 4-wheel drive. Be aware of the difference and use carefully.
3. Always slow the tractor down before turning. Turning at high speed may tip the tractor over.
4. Observe all local traffic and safety regulations.
5. Turn the headlights on. Dim them when meeting another vehicle.
6. Drive at speeds that allow you to maintain control at all times.
7. Do not apply the differential lock while traveling at road speeds. The tractor may run out of control.
8. Avoid sudden motions of the steering wheel as they can lead to a dangerous loss of stability. The risk is especially great when the tractor is traveling at road speeds.
9. Keep the ROPS in the "UP" position and wear the seat belt when driving the tractor on the road. Otherwise, you will not be protected in the event of a tractor roll-over.
10. Do not operate an implement while the tractor is on the road. Lock the 3-point hitch in the raised position.

▲-4 SAFE OPERATION

11. Do not ride or stand on the step during operation. Riding or standing there could result in being crushed under the rear tire due to slippage or the step fracturing or displacing due to unintended loading.

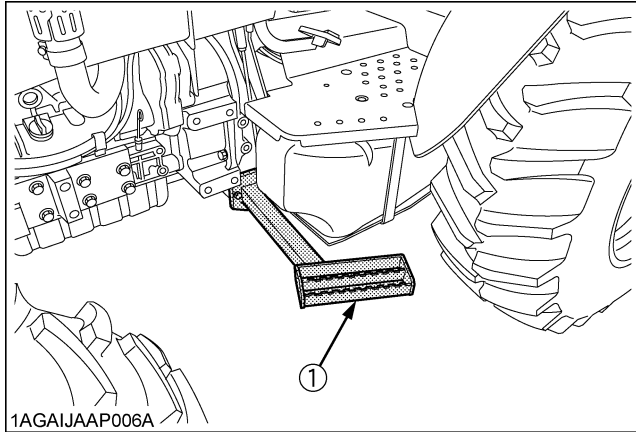

(1) Step

12. Set the implement lowering speed knob in the "LOCK" position to hold the implement in the raised position.

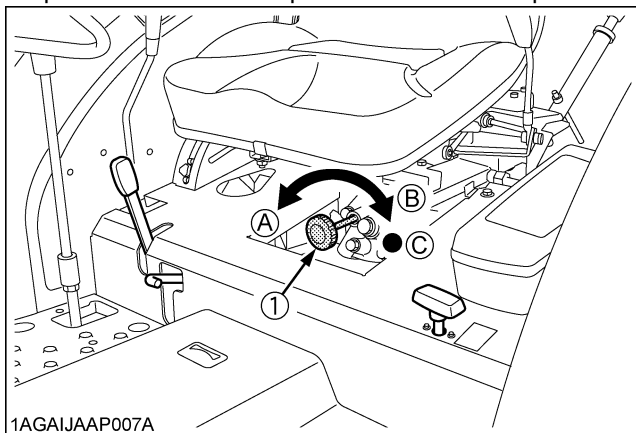

(1) 3-point hitch lowering speed knob

(A) "FAST"
(B) "SLOW"
(C) "LOCK"

3. PARKING THE TRACTOR

1. Disengage the PTO, lower all implements to the ground, place all control levers in their neutral positions, set the parking brake, stop the engine, remove the key from the ignition and lock the cab door (if equipped). Leaving transmission in gear with the engine stopped will not prevent tractor from rolling.
2. Make sure that the tractor has come to a complete stop before dismounting.
3. Avoid parking on steep slopes, if at all possible park on a firm and level surface; if not, park across a slope with chock the wheels.
Failure to comply with this warning may allow the tractor to move and could cause injury or death.

4. OPERATING THE PTO

1. Wait until all moving components have completely stopped before getting off the tractor, connecting, disconnecting, adjusting, cleaning, or servicing any PTO driven equipment.
2. Keep the PTO shaft cover in place at all times. Replace the PTO shaft cap when the shaft is not in use.

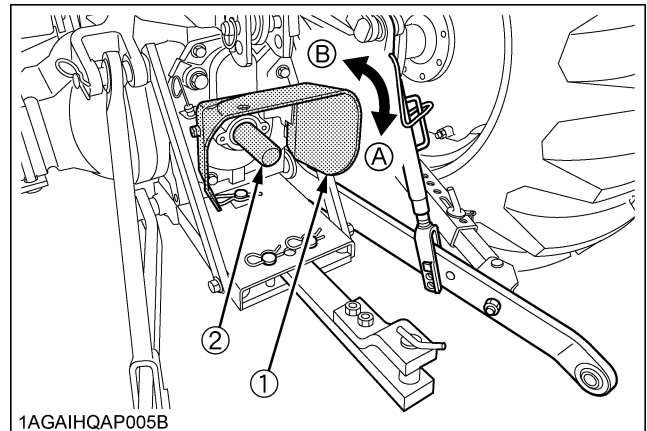

(1) PTO Shaft cover
(2) PTO Shaft cap

(A) "NORMAL POSITION"
(B) "RAISED POSITION"

3. Before installing or using PTO driven equipment, read the manufacturer's manual and review the safety labels attached to the equipment.
4. When operating stationary PTO driven equipment, always apply the tractor parking brake and place chocks behind and in front of the rear wheels. Stay clear of all rotating parts. Never step over rotating parts.

5. USING 3-POINT HITCH

1. Use the 3-point hitch only with equipment designed for 3-point hitch usage.
2. When using a 3-point hitch mounted implement, be sure to install the proper counterbalance weight on the front of the tractor.

3. To avoid injury from separation:
Do not extend lift rod beyond the groove on the threaded rod.

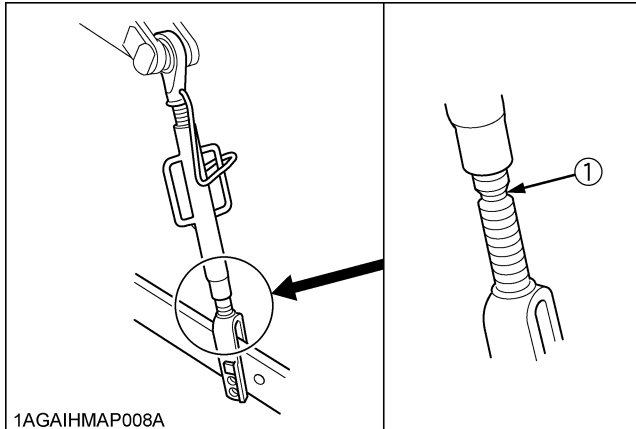

1AGAIHMAP008A

(1) Groove

6. SERVICING THE TRACTOR

Before servicing the tractor, park it on a firm, flat and level surface, set the parking brake, lower all implements to the ground, place the gear shift lever in neutral, stop the engine and remove the key.

1. Allow the tractor time to cool off before working on or near the engine, muffler, radiator, etc.
2. Do not remove radiator cap while coolant is hot. When cool, slowly rotate cap to the first stop and allow sufficient time for excess pressure to escape before removing the cap completely. If the tractor has a coolant recovery tank, add coolant or water to the tank, not the radiator. (See "Checking Coolant Level" in "DAILY CHECK" in "PERIODIC SERVICE" section.)
3. Always stop the engine before refueling. Avoid spills and overfilling.
4. Do not smoke when working around battery or when refueling. Keep all sparks and flames away from battery and fuel tank. The battery presents an explosive hazard, because it gives off hydrogen and oxygen especially when recharging.
5. Before "jump starting" a dead battery, read and follow all of the instructions. (See "JUMP STARTING" in "OPERATING THE ENGINE" section.)
6. Keep first aid kit and fire extinguisher handy at all times.
7. Disconnect the battery's ground cable before working on or near electric components.
8. To avoid the possibility of battery explosion, do not use or charge the refillable type battery if the fluid level is below the LOWER (lower limit level) mark. Check the fluid level regularly and add distilled water as required so that the fluid level is between the UPPER and LOWER levels.

9. To avoid sparks from an accidental short circuit, always disconnect the battery's ground cable (-) first and reconnect it last.

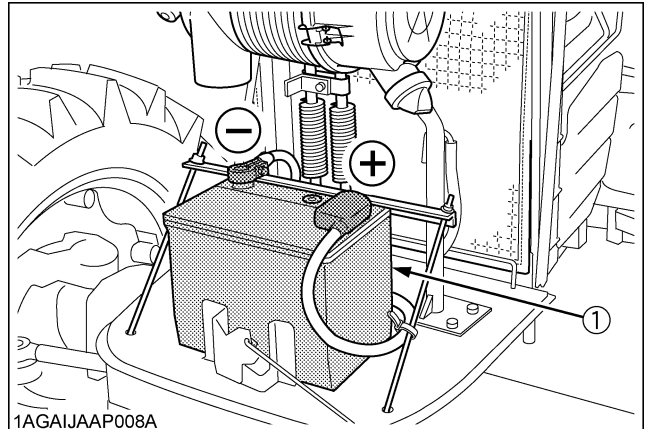

1AGAIJAP008A

(1) Battery

10. Do not attempt to mount a tire on a rim. This should be done by a qualified person with the proper equipment.
11. Always maintain the correct tire pressure. Do not inflate tires above the recommended pressure shown in the operator's manual.

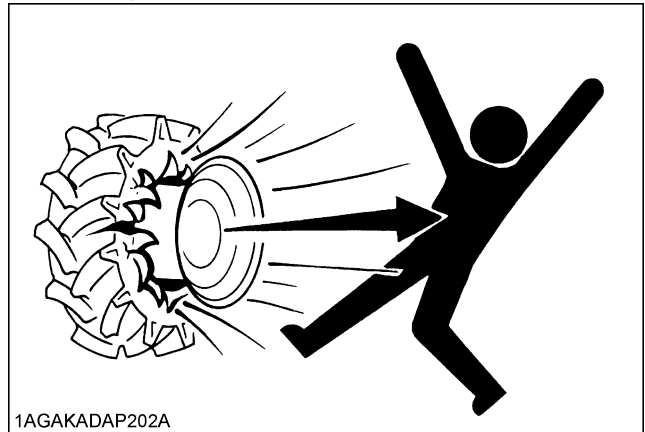

1AGAKADAP202A

12. Securely support the tractor when either changing wheels or adjusting the wheel tread width.
13. Make sure that wheel bolts have been tightened to the specified torque.
14. Do not work under any hydraulically supported devices. They can settle, suddenly leak down, or be accidentally lowered. If it is necessary to work under tractor or any machine elements for servicing or adjustment, securely support them with stands or suitable blocking beforehand.

▲-6 SAFE OPERATION

15. Escaping hydraulic fluid under pressure has sufficient force to penetrate skin, causing serious personal injury. Before disconnecting hydraulic lines, be sure to release all residual pressure. Before applying pressure to the hydraulic system, make sure that all connections are tight and that all lines, pipes, and hoses are free of damage.



1BAACAAAP010B

16. Fluid escaping from pinholes may be invisible. Do not use hands to search for suspected leaks; use a piece of cardboard or wood. Use of safety goggles or other eye protection is also highly recommended. If injured by escaping fluid, see a medical doctor at once. This fluid will produce gangrene or severe allergic reaction.

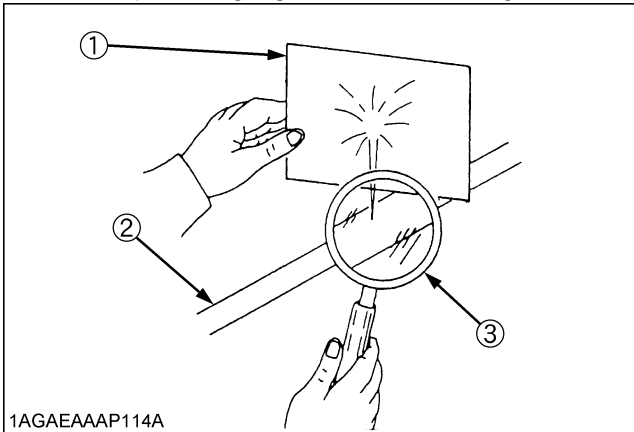

1AGAEAAAP114A

- (1) Cardboard
- (2) Hydraulic line
- (3) Magnifying glass

7. DANGER, WARNING AND CAUTION LABELS

(1) Part No. 6C090-4958-2

Do not get your hands close to engine fan and fan belt.



1AGAIAZAP110A

(2) Part No. 32310-4958-1

Do not touch hot surface like muffler, etc.

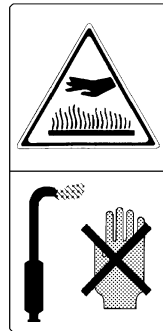

1AGAIAZAP071A

(3) Part No. 3F240-9857-1



1AGAIBDAP039A

(4) Part No. TA040-4965-2



1AGAIAZAP009A

(5) Part No. 3A111-9801-1

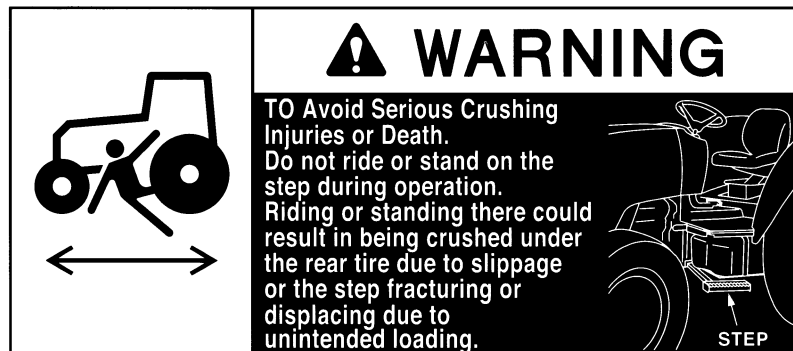

1AGAIHAP099A

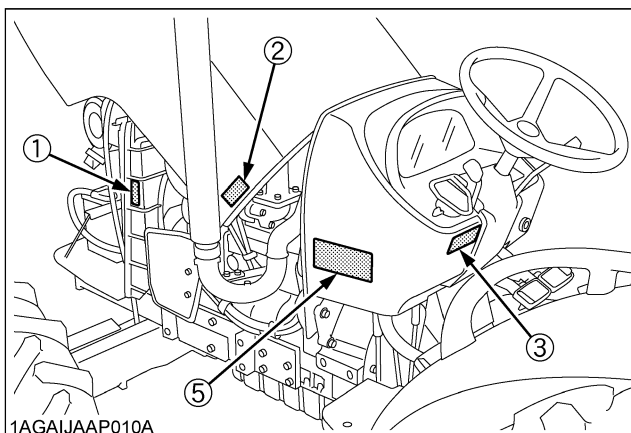

1AGAIJAP010A

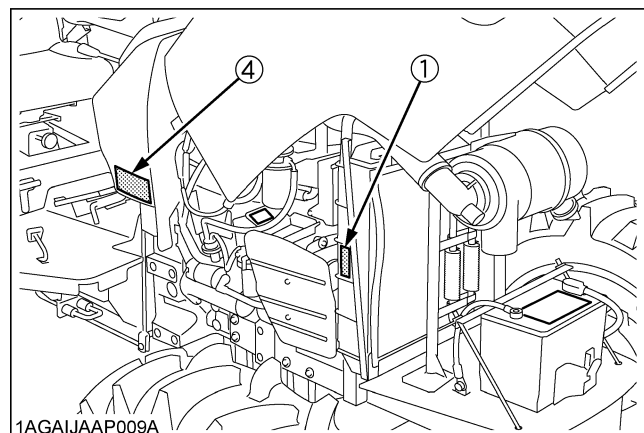

1AGAIJAP009A

1AGAIJAP045A

(1) Part No. 6C040-4742-2

▲ CAUTION

TO AVOID PERSONAL INJURY:

1. Read and understand the operator's manual before operation.
2. Before starting the engine, make sure that everyone is at a safe distance from the tractor and that the PTO is OFF.
3. Do not allow passengers on the tractor at any time.
4. Before allowing other people to use the tractor, have them read the operator's manual.
5. Check the tightness of all nuts and bolts regularly.
6. Keep all shields in place and stay away from all moving parts.
7. Lock the two brake pedals together before driving on the road.
8. Slow down for turns, or rough roads, or when applying individual brakes.
9. On public roads use SMV emblem and hazard lights, if required by local traffic and safety regulations.
10. Pull only from the drawbar.
11. Before dismounting, lower the implement to the ground, set the parking brake, stop the engine and remove the key.
12. Securely support tractor and implements before working underneath.

1AGAIAP109A

(2) Part No. 3A111-9848-2

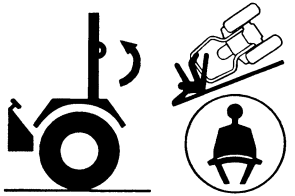
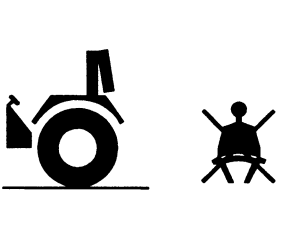
	<p style="text-align: center;">▲ WARNING</p> <p>TO AVOID INJURY OR DEATH FROM ROLL-OVER:</p> <ul style="list-style-type: none"> • Keep Roll-Over Protective Structures (ROPS) in the upright and locked position. • Fasten SEAT BELT before operating.
	<p>THERE IS NO OPERATOR PROTECTION WHEN THE ROPS IS IN THE FOLDED POSITION.</p> <ul style="list-style-type: none"> • Check the operating area and fold the ROPS only when absolutely necessary. • Do not wear SEAT BELT if ROPS is folded. • Raise and lock ROPS as soon as vertical clearance allows. • Read ROPS related instructions and warnings.

1AGAIIDCAP066E

(3) Part No. 3A481-9853-1

Diesel fuel only No fire

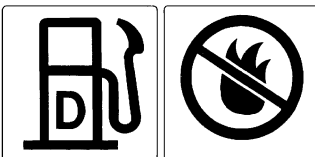

1AGAIAP118A

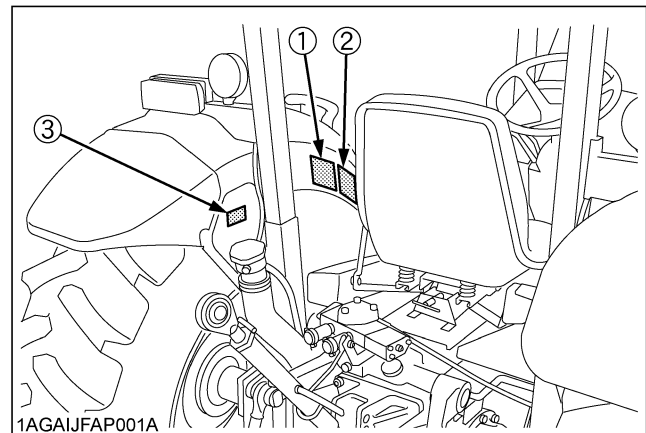

1AGAIJFAP001A

1AGAIJFAP002A

(1) Part No. 3A111-9554-1

⚠ WARNING

Never modify or repair a ROPS because welding, grinding, drilling or cutting any portion may weaken the structure.

⚠ CAUTION



TO AVOID INJURY WHEN RAISING OR FOLDING ROPS:

- Set parking brake and stop engine.
- Remove any obstruction that may prevent raising or folding of the ROPS.
- Do not allow any bystanders.
- Always perform function from a stable position at the rear of the tractor.
- Hold the top of the ROPS securely when raising or folding.
- Make sure all pins are installed and locked.

1AGAIAP076A

(2) Part No. 3Y205-9892-1

⚠ DANGER/POISON

 SHIELD EYES. EXPLOSIVE GASES CAN CAUSE BLINDNESS OR INJURY.	 NO SPARKS *FLAMES *SMOKING	 SULFURIC ACID CAN CAUSE BLINDNESS OR SEVERE BURNS.
--	---	---

KEEP OUT OF REACH OF CHILDREN. DO NOT TIP. DO NOT OPEN BATTERY.

FLUSH EYES IMMEDIATELY WITH WATER.  **GET MEDICAL HELP FAST.**

PROPOSITION 65 WARNING
 BATTERY POSTS, TERMINALS, AND RELATED ACCESSORIES CONTAIN LEAD AND LEAD COMPOUNDS, CHEMICALS KNOWN TO THE STATE OF CALIFORNIA TO CAUSE CANCER AND REPRODUCTIVE HARM. WASH HANDS AFTER HANDLING.

105E41R 12V	
AMP. HR (5HR)	80
AMP. HR (20HR)	100
RESERVE CAPACITY (MIN)	160
BCI CCA	900
EN CCA	800

 SOC INDICATOR

 OK

 CHARGE REPAIR BATTERY

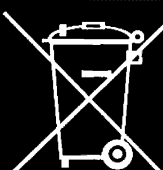
Pb

 RECYCLE

DK 85330

(3) Part No. 3A272-9856-1

⚠ CAUTION

TO AVOID INJURY FROM SEPARATION :

DO NOT EXTEND LIFT ROD BEYOND THE GROOVE ON THE THREADED ROD.

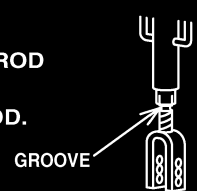

GROOVE

1AGAIHAP077A

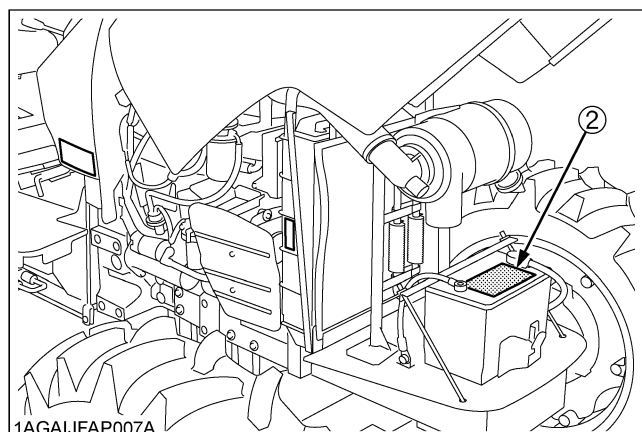
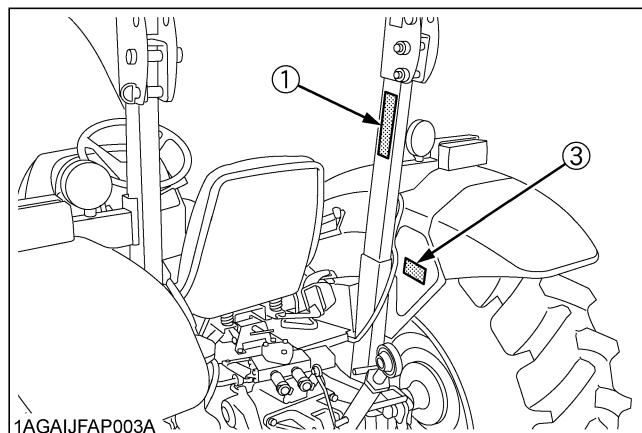

1AGAIJFAP004A

(1) Part No. 6C150-4743-1

 WARNING	<p>BEFORE DISMOUNTING TRACTOR:</p> <ol style="list-style-type: none"> 1. ALWAYS SET PARKING BRAKE. Leaving transmission in gear with the engine stopped will not prevent tractor from rolling. 2. PARK ON LEVEL GROUND WHENEVER POSSIBLE. If parking on a slope, position tractor across the slope. 3. LOWER ALL IMPLEMENTS TO THE GROUND. 4. STOP THE ENGINE.
	



1AGAIBDAP040E

(2) Part No. TA040-4935-1

 WARNING
<p>TO AVOID PERSONAL INJURY:</p> <ol style="list-style-type: none"> 1. Attach pulled or towed loads to the drawbar only. 2. Use the 3-point hitch only with equipment designed for 3-point hitch usage.

1AGAIAZAP056A

(3) Part No. TA040-4959-3

	<p style="text-align: center;"> WARNING</p> <p>TO AVOID PERSONAL INJURY.</p> <ol style="list-style-type: none"> 1. Keep PTO shield in place at all times. 2. Do not operate the PTO at speeds faster than the speed recommended by the implement manufacturer. 3. For trailing PTO-driven implements, set drawbar at towing position. (see operator's manual)
---	---

1AGAIAZAP116A

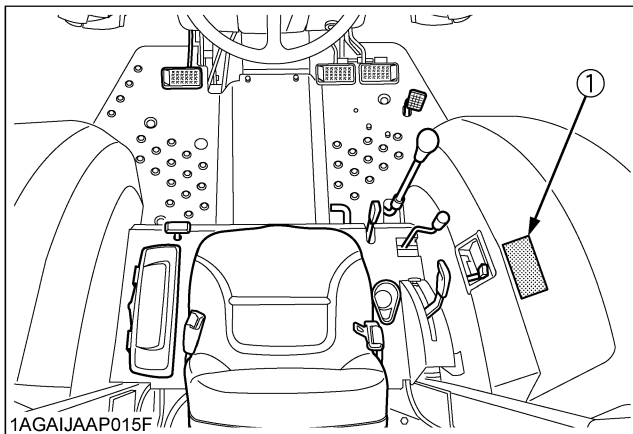

1AGAIJAP015F

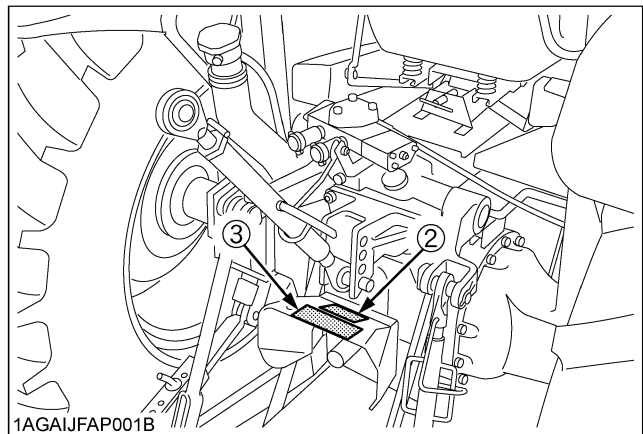

1AGAIJFAP001B

1AGAIJFAP005A

8. CARE OF DANGER, WARNING AND CAUTION LABELS

1. Keep danger, warning and caution labels clean and free from obstructing material.
2. Clean danger, warning and caution labels with soap and water, dry with a soft cloth.
3. Replace damaged or missing danger, warning and caution labels with new labels from your local KUBOTA Dealer.
4. If a component with danger, warning and caution label(s) affixed is replaced with new part, make sure new label(s) is (are) attached in the same location(s) as the replaced component.
5. Mount new danger, warning and caution labels by applying on a clean dry surface and pressing any bubbles to outside edge.

SPECIFICATIONS

SPECIFICATION TABLE

Model			M7040SUH
			4WD
Engine	Model		V3307-DI-TE2
	Type		Direct Injection, liquid cooled 4 cylinder diesel
	Number of cylinders		4
	Total displacement	cm ³	3331
	Bore and stroke	mm	94 x 120
	Rated revolution	rpm	2600
	Low idling revolution	rpm	875 to 925
	Net power *1	kW (HP)	50.7 (68)
	PTO power *1 (factory observed)	kW (HP)	46.2 (62)
	Maximum torque	N-m / rpm	232 / 1500 to 1700
	Battery capacity		12V, RC: 160 min, CCA 900A
	Fuel tank capacity	L	70
	Engine oil capacity	L	11
	Coolant capacity	L	8
Dimensions	Overall length		mm 3500
	Overall width (minimum tread)		mm 1860
	Overall height		mm 2470
	Wheel base		mm 2050
	Tread	Front	mm 1420, 1520
		Rear	mm 1420 to 1720
	Minimum ground clearance		mm 415 (Fuel tank stay)
Weight		kg 2090	
Traveling system	Standard tire size	Front tires	9.5-24
		Rear tires	16.9-30
	Clutch		Multiple wet disks
	Steering		Hydraulic Power Steering
	Braking system		Multiple wet disks mechanical
	Differential		Bevel gears with differential lock (Rear)

2 SPECIFICATIONS





Model			M7040SUH		
			4WD		
Hydraulic unit	Hydraulic control system		Position control		
	Pump capacity	L / min	43.9		
	3-point hitch		Category 1 and 2		
	Max. lifting force	At lifting points	kg	1900 At lower link end with links horizontal	
		24 in. behind lifting point	kg	1500	
	Remote hydraulic control		1 standard with detent and self cancelling (2nd and 3rd valve optional)		
	System pressure	MPa (kgf/cm ²)	19.1 (195)		
Traction system		Swinging drawbar, adjustable in direction			
PTO	Live PTO (Independent)	Direction of turning		Clockwise, viewed from tractor rear	
		PTO/Engine speed	rpm	6 spline: 540 / 2295	

The company reserves the right to change the specifications without notice.

NOTE: *1 Manufacturer's estimate

TRAVELING SPEEDS

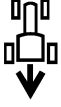
(At rated engine rpm)

Model			M7040SUH	
Tire size (Rear)			16.9-30	
Shuttle shift lever	Range gear shift lever	Main gear shift lever	km/h	mph
Forward 		1	2.8	1.7
		2	3.9	2.4
		3	5.4	3.4
		4	8.3	5.2
		1	10.5	6.5
		2	14.8	9.2
		3	20.7	12.9
		4	31.5	19.7
Reverse 		1	2.8	1.8
		2	4.0	2.5
		3	5.5	3.5
		4	8.4	5.3
		1	10.7	6.7
		2	15.1	9.4
		3	21.1	13.2
		4	32.2	20.1

The company reserves the right to change the specifications without notice

INSTRUMENT PANEL AND CONTROLS

■ Instrument Panel, Switches and Hand Controls

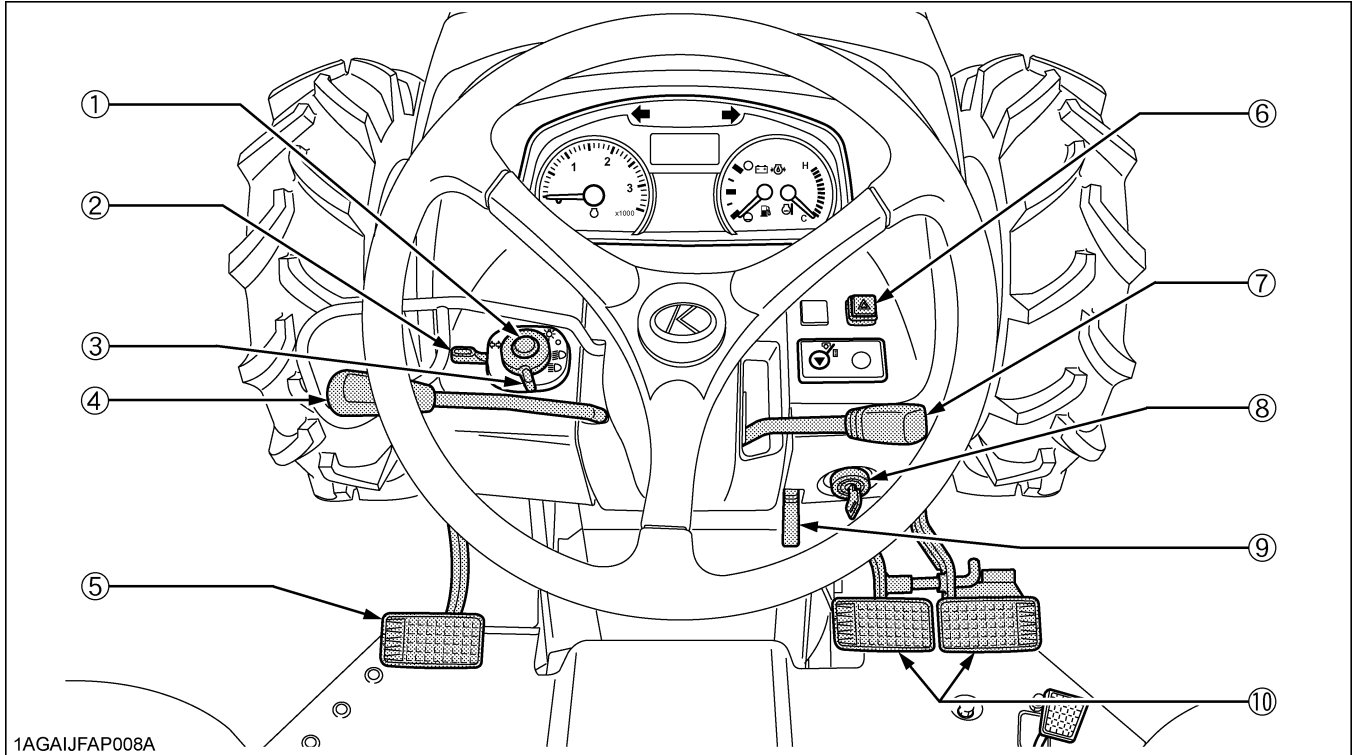

1AGAIJFAP008A

ILLUSTRATED CONTENTS

(1) Horn button	6
(2) Turn signal light switch	6
(3) Head light switch	*
(4) Hydraulic-shuttle shift lever	*
(5) Clutch pedal	*
(6) Hazard light switch	6
(7) Hand throttle lever	*
(8) Key switch	*
(9) Parking brake lever	*
(10) Brake pedal	*

* See operator's manual issued separately for the sister model. [M7040SUHD]

■ Foot and Hand Controls

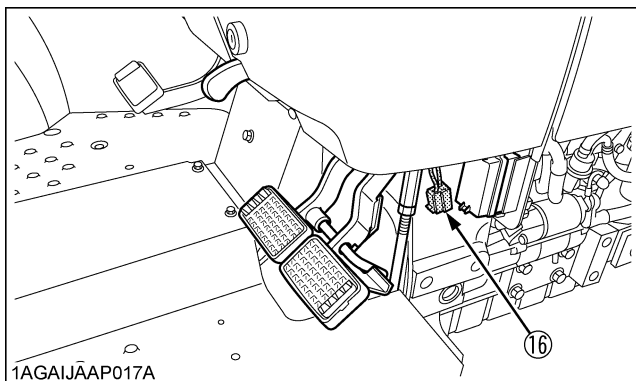
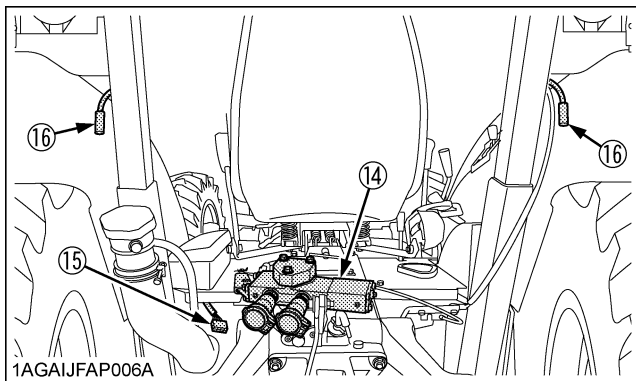
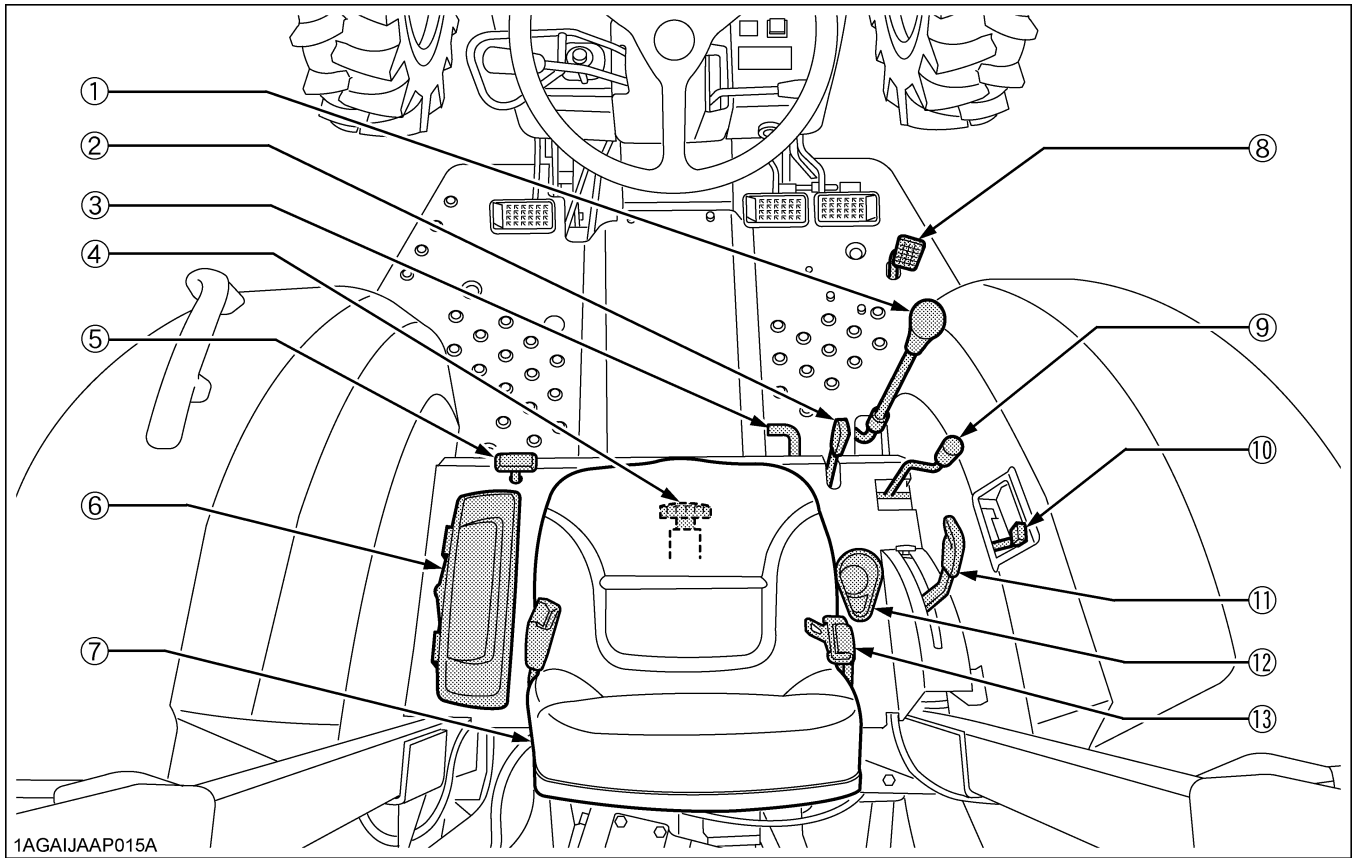

ILLUSTRATED CONTENTS

(1) Main gear shift lever	*
(2) Range gear shift lever	*
(3) Differential lock pedal	*
(4) 3-Point hitch lowering speed knob	*
(5) Front wheel drive lever	*
(6) Tool box	*
(7) Operator's seat	*
(8) Foot throttle	*
(9) Remote control valve lever	8
(10) PTO clutch control lever	*
(11) Position control lever	*
(12) Cup holder	*
(13) Seat belt	*
(14) Remote control valve	8
(15) Trailer electrical outlet	*
(16) Electrical outlet	*

OPERATING THE TRACTOR

STARTING

■ Turn Signal / Hazard Light Switch

◆ Turn Signal Light Switch

To indicate a right turn, turn the turn signal light switch clockwise. To indicate a left turn, turn the turn signal light switch counter-clockwise. The corresponding right and left turn signal lights and indicator on the instrument panel will flash. Turn signal is active when key switch is in the "ON" position.

NOTE :

- Be sure to return switch to center position after turning.

◆ Hazard Light Switch

When hazard light switch is pushed, the hazard lights flash along with the indicator on the instrument panel. Press the hazard light switch again to turn off the light.

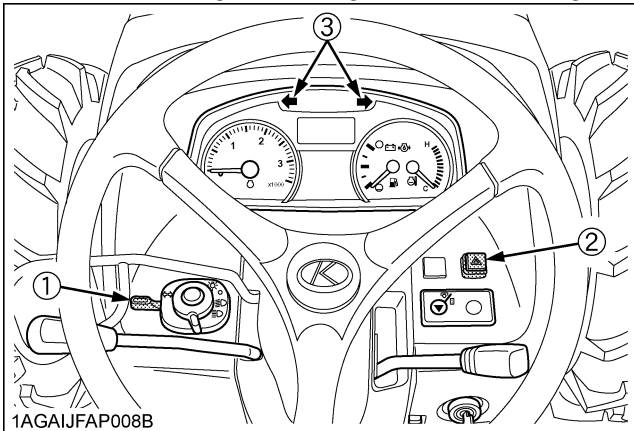

- (1) Turn signal light switch
- (2) Hazard light switch
- (3) Hazard / Turn signal indicator

■ Horn Button

The horn will sound when the key switch is in the "ON" position and the horn button pressed.

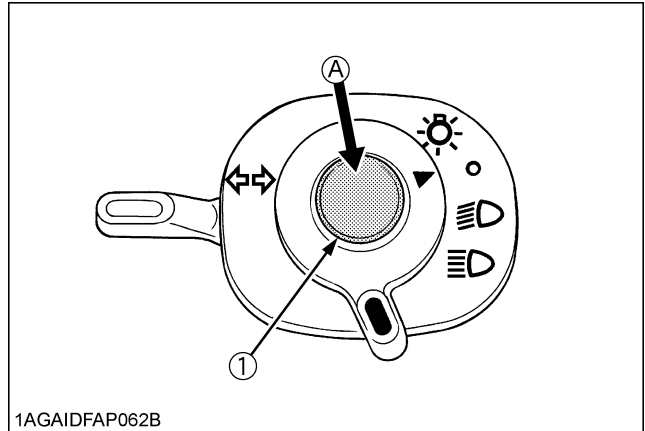

1AGAIJFAP062B

(1) Horn button

(A) "PUSH"

3-POINT HITCH & DRAWBAR

DRAWBAR



WARNING

To avoid personal injury or death:

- Never pull from the top link, the rear axle or any point above the drawbar. Doing so could cause the tractor to tip over rearward causing personal injury or death.

■ Adjusting Drawbar Length

When towing an implement, it is recommended that the (A) hole in drawbar be utilized.

The drawbar load is specified in the "IMPLEMENT LIMITATIONS" section.

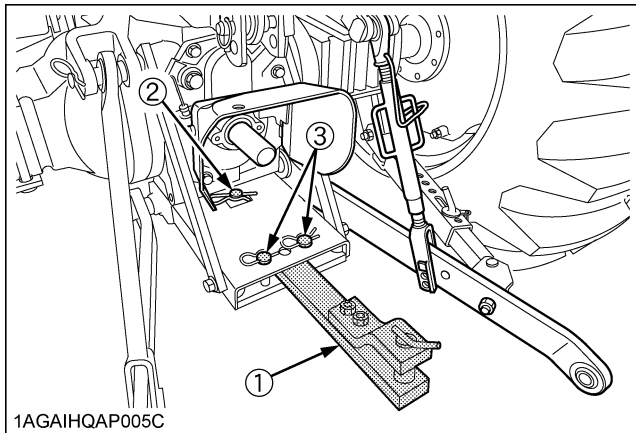

1AGAIHQAP005C

■ Swing Drawbar

The drawbar can be used in 3 different ways as illustrated below. Assemble it correctly with locating pins.

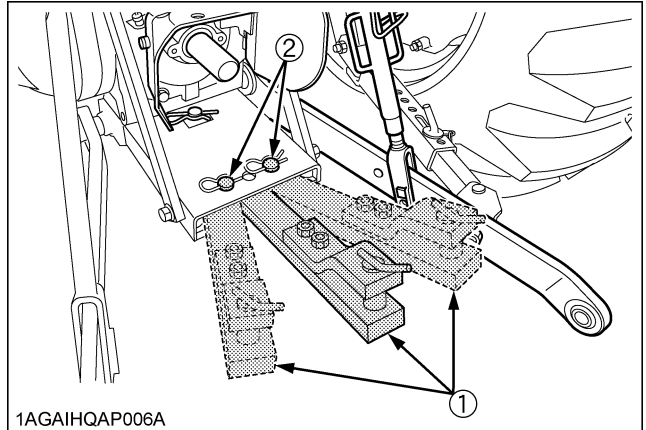

1AGAIHQAP006A

- (1) Drawbar
(2) Locating pin

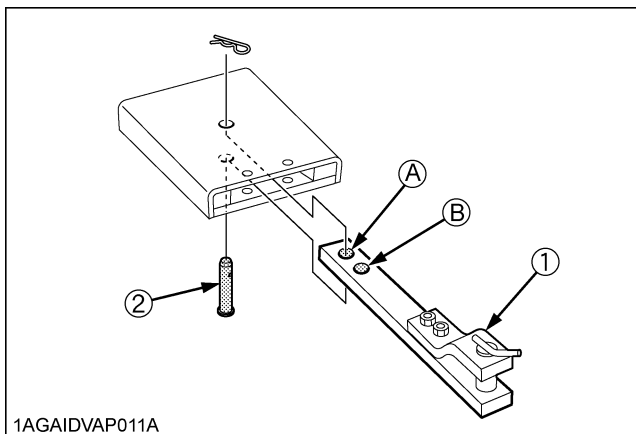

1AGAIHQAP011A

- (1) Drawbar
(2) Pivot pin

Holes: (A), (B)

HYDRAULIC UNIT

REMOTE HYDRAULIC CONTROL SYSTEM

The hydraulic auxiliary control valves can be installed up to triple segments.

Remote Control Valve

There are 3 types of remote valves available for these models.

- Double acting valve with detents and self cancelling:
This valve may be placed in the detent mode. The lever will stay in this position until the pressure reaches a predetermined level or a cylinder reaches the end of its stroke. Then it will automatically return to neutral.
- Double acting valve with float position:
This valve may be placed in the float mode with the control lever all the way forward. The cylinder is free to extend or retract, letting an implement such as a loader bucket follow the ground.
- Single/double acting valve:
This valve can be utilized as single or double acting valve by adjusting the auxiliary control valve selector knob located on the valve.
 - 1) Turn the auxiliary control valve selector knob clockwise all the way to utilize as single acting valve.
 - 2) Turn the auxiliary control valve selector knob anticlockwise all the way to utilize as double acting valve.

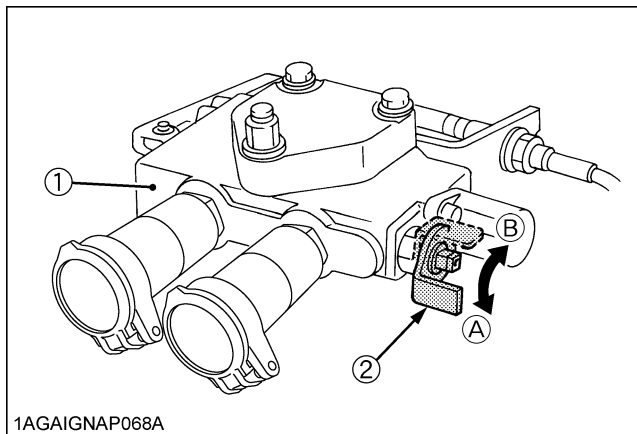

(1) Single / double acting valve
(2) Auxiliary control valve selector knob
(A) Double acting
(B) Single acting

NOTE :

Standard mounted valve:

- Lever 1 Double acting valve with detents and self cancelling

Remote Control Valve Lever

The remote control valve lever directs pressurized oil flow to the implement hydraulic system.

[Example: Installing triple segment valve]

1st	Double acting valve with detents and self cancelling
2nd	Double acting valve with float position
3rd	Single / Double acting valve

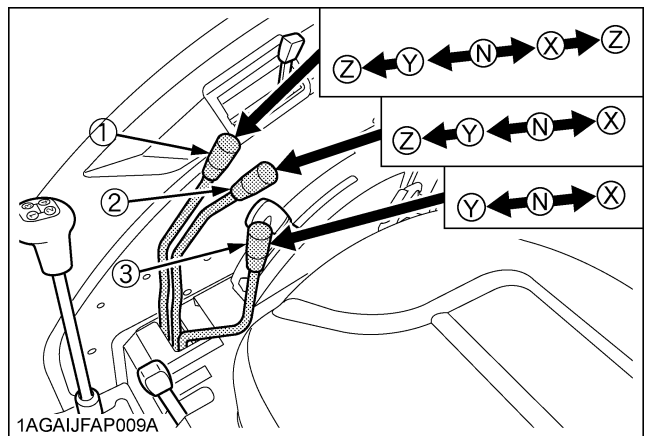

(1) Remote control valve lever with double acting valve (1)
(2) Remote control valve lever with double acting valve / float position (2)
(3) Remote control valve lever with single / double acting valve (3)

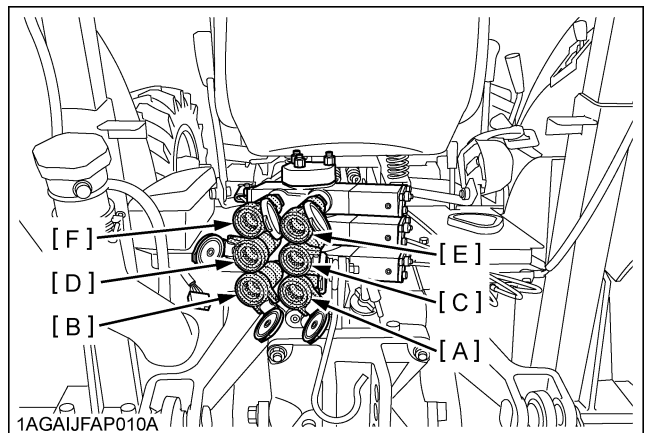

Pressure →
 Returning ←

Lever (1)		Lever position			
		Z (detent)	Y	X	Z (detent)
Port	[A]	out →		in ←	
	[B]	in ←		out →	

Lever (2)		Lever position			
		Z (detent)	Y	X	
Port	[C]	in	Float	out →	in ←
	[D]	out		in ←	out →

Lever (3)		Lever position			
		Double-acting		Single-acting	
		Y	X	Y	X
Port	[E]	out →	in ←	-	-
	[F]	in ←	out →	in ←	out →

IMPORTANT :

- Do not hold the lever in the "pull" or "push" position once the remote cylinder has reached the end of the stroke, as this will cause oil to flow through the relief valve. Forcing oil through the relief valve for extended periods will overheat the oil.
- When using the tractor hydraulic system to power front loader, do not operate boom and bucket cylinders simultaneously.

NOTE :

- Connect the pressure of load side of implement cylinders to ports [B], [D] or [F] which have built in load check valve to prevent leak down.
- To use the single-acting cylinder with the float valve, connect this cylinder to the [B], [D] or [F] port. To extend a single-acting cylinder, pull the remote control valve lever rearward. To retract a cylinder, push it fully forward to the "FLOAT" position. Do not hold it in the down position, the transmission fluid may be overheat.

PERIODIC SERVICE

SERVICE AS REQUIRED

■ Replacing Fuse

The tractor electrical system is protected from potential damage by fuses.

A blown fuse indicates that there is an overload or short somewhere in the electrical system.

If any of the fuses should blow, replace with a new one of the same capacity.

IMPORTANT :

- Before replacing a blown fuse, determine why the fuse blew and make any necessary repairs. Failure to follow this procedure may result in serious damage to the tractor electrical system. Refer to the "TROUBLESHOOTING" section of this manual or your local KUBOTA Dealer for specific information dealing with electrical problems.

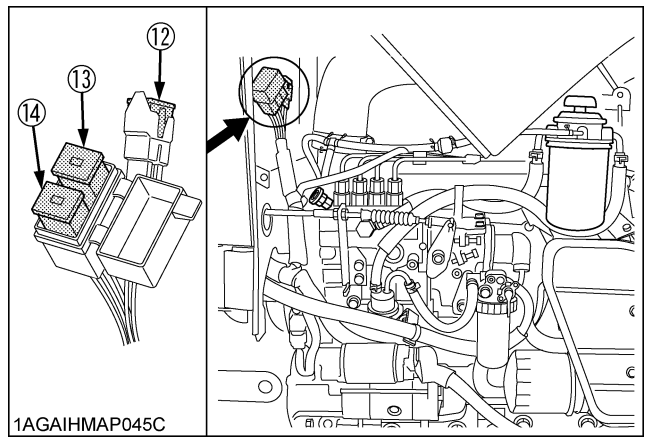
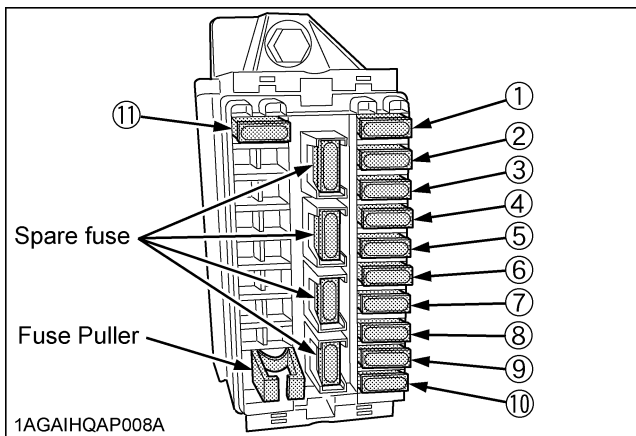
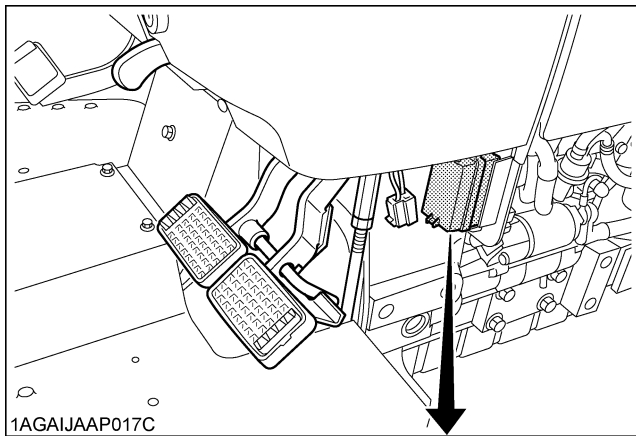

FUSE No.	CAPACITY (A)	Protected circuit
(1)	15	Work Light (R)
(2)	15	Work Light (L)
(3)	5	Alternator, Engine, Glow Plug
(4)	5	Meter Panel, OPC
(5)	10	Turn Signal
(6)	15	Auxiliary Power
(7)	5	Meter (Back Up)
(8)	20	Head Light, Tail Lamp
(9)	15	Flasher (Hazard)
(10)	5	Starter Relay
(11)	10	Horn
(12)	50	Charge, Glow Plug
(13)	30	Fuel Cut Solenoid, Work Light
(14)	40	Key switch, Head Light, Hazard

■ Replacing Light Bulb

Light	Capacity
Head light	12 V, 55 / 60 W (H4)
Hazard and turn signal light (Round)	12 V, 23 W
Hazard and turn signal light	12 V, 21 W
Brake stop light / Tail light	12 V, 21 / 5 W

OPTIONS

Consult your local KUBOTA Dealer for further details.

- Double Acting Remote Hydraulic Control Valve with Detents and Self-Cancelling
- Double Acting Remote Hydraulic Control Valve with Float Position
- Front end weights
For front ballast
- Rear Wheel Weights
For rear ballast
- Trailer Electrical Outlet
For operating remote lighting