



- U.S.A. : **KUBOTA TRACTOR CORPORATION**  
1000 Kubota Drive, Grapevine, TX 76051  
Telephone : 888-4KUBOTA
- Canada : **KUBOTA CANADA LTD.**  
5900 14th Avenue, Markham, Ontario, L3S 4K4, Canada  
Telephone : (905)294-7477
- France : **KUBOTA EUROPE S.A.S**  
19-25, Rue Jules Vercey, Z.I. BP88, 95101 Argenteuil Cedex, France  
Telephone : (33)1-3426-3434
- Italy : **KUBOTA EUROPE S.A.S Italy Branch**  
Via Grandi, 29 20068 Peschiera Borrome (MI) Italy  
Telephone : (39)02-51650377
- Germany : **KUBOTA (DEUTSCHLAND) GmbH**  
Senefelder Str. 3-5 63110 Rodgau /Nieder-Roden, Germany  
Telephone : (49)6106-873-0
- U.K. : **KUBOTA (U.K.) LTD.**  
Dormer Road, Thame, Oxfordshire, OX9 3UN, U.K.  
Telephone : (44)1844-214500
- Spain : **KUBOTA ESPAÑA S.A.**  
Avenida Recomba No.5, Poligno Industrial la Laguna, Leganes, 28914 (Madrid) Spain  
Telephone : (34)91-508-6442
- Australia : **KUBOTA AUSTRALIA PTY LTD.**  
25-29 Permas Way, Truganina, VIC 3029, Australia  
Telephone : (61)-3-9394-4400
- Malaysia : **KUBOTA MALAYSIA SDN. BHD.**  
No.3 Jalan Sepadu 25/123 Taman Perindustrian Axis,  
Seksyen 25, 40400 Shah Alam, Selangor Darul Ehsan Malaysia  
Telephone : (60)3-736-1388
- Philippines : **KUBOTA PHILIPPINES, INC.**  
232 Quirino Highway, Baesa, Quezon City 1106, Philippines  
Telephone : (63)2-422-3500
- Taiwan : **SHIN TAIWAN AGRICULTURAL MACHINERY CO., LTD.**  
16, Fengping 2nd Rd, Taliiao Shiang Kaohsiung 83107, Taiwan R.O.C.  
Telephone : (886)7-702-2333
- Indonesia : **PT KUBOTA MACHINERY INDONESIA**  
Tower A at EightyEight@Kasablanka Lantai 16  
Jalan Raya Casablanka Kav. 88, Jakarta 12870 Indonesia  
Telephone : (62)-21-29568-720
- Thailand : **SIAM KUBOTA CORPORATION CO., LTD.**  
101/19-24 Moo 20, Navanakorn Industrial Estate, Tambon Khlongnueng, Amphur Khlongluang,  
Pathumthani 12120, THAILAND  
Telephone : (66)2-909-0300
- Korea : **KUBOTA KOREA CO., LTD.**  
41-27, Jayumyeok-gil, Baeksan-myeon, Gimje-si, Jeollabuk-do, Korea  
Telephone : (82)-63-544-5822
- India : **KUBOTA AGRICULTURAL MACHINERY INDIA PVT. LTD.**  
No.15, Medavakkam Road, Sholinganallur, Chennai-600119, T.N., India  
Telephone : (91)44-6104-1500
- Vietnam : **KUBOTA VIETNAM CO., LTD.**  
Lot B-3A2-CN, My Phuoc 3 Industrial Park, Thoi Hoa Ward, Ben Cat Town, Binh Duong Province, Vietnam  
Telephone : (84)-274-3577-507

KUBOTA Corporation

AX . J . 1 - 1 . . . AK

English (Australia)  
Code No. K3287-7126-1

# OPERATOR'S MANUAL

# KUBOTA ZERO TURN MOWER

MODEL ZG327A-AU

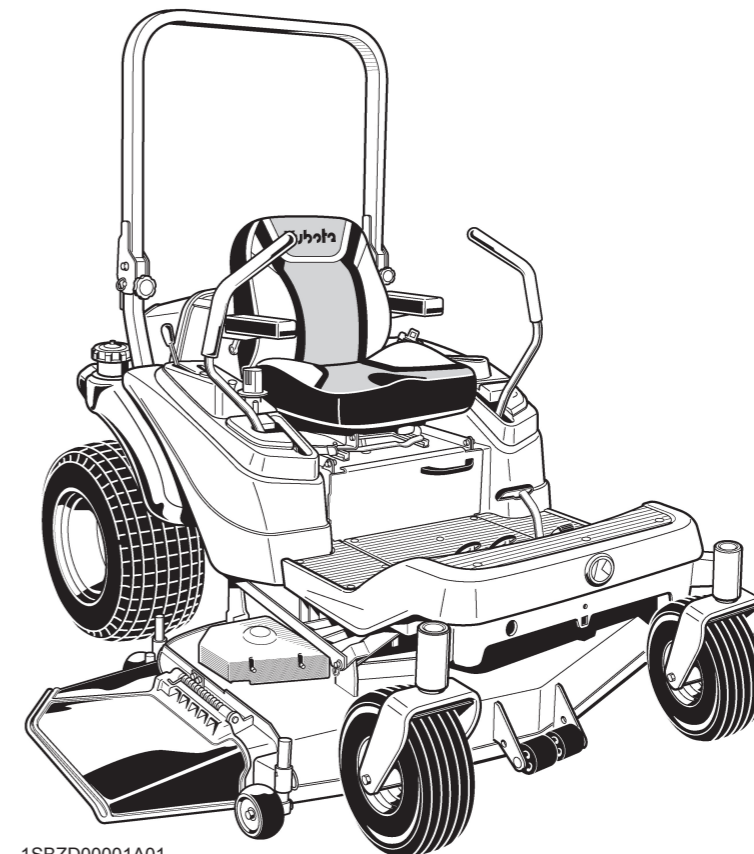

1SBZD00001A01

Z  
G  
3  
2  
7  
A  
·  
A  
U

READ AND SAVE THIS MANUAL



# ABBREVIATION LIST

Abbreviations	Definitions
API	American Petroleum Institute
ASTM	American Society for Testing and Materials, USA
fpm	Feet Per Minute
HST	Hydrostatic Transmission
m/s	Meters Per Second
PTO	Power Take Off
RH/LH	Right-hand and left-hand sides are determined by facing in the direction of forward travel
ROPS	Roll-Over Protective Structures
rpm	Revolutions Per Minute
r/s	Revolutions Per Second
SAE	Society of Automotive Engineers

## KUBOTA Corporation is ...

Since its inception in 1890, KUBOTA Corporation has grown to rank as one of the major firms in Japan.

To achieve this status, the company has through the years diversified the range of its products and services to a remarkable extent, until today, 30 plants and 35,000 employees produce over 1,000 different items, large and small.





















All these products and all the services which accompany them, however, are unified by one central commitment. KUBOTA makes products which, taken on a national scale, are basic necessities. Products which are indispensable, products intended to help individuals and nations fulfill the potential inherent in their environment. For KUBOTA is the Basic Necessities Giant.

This potential includes water supply, food from the soil and from the sea, industrial development, architecture, construction and transportation.

Thousands of people depend on KUBOTA's know-how, technology, experience and customer service. You too can depend on KUBOTA.

# UNIVERSAL SYMBOLS

As a guide to the operation of your machine, various universal symbols have been utilized on the instruments and controls. The symbols are shown below with an indication of their meaning.

- |   |  |
|---|--|
|  Safety Alert Symbol                                     |  Hours                  |
|  Gasoline Fuel   |  Cutting Height         |
|  Fuel-Level  |  Mower-Lowered position |
|  Fuel-Level Warning                                      |  Mower-Raised position  |
|  Parking Brake   |  Fast                   |
|  Engine-Stop   |  Slow                   |
|  Engine-Run  |  Engine Speed Control   |
|  Starter Control   |  Battery                |
|  Power Take-Off Clutch Control-Off Position (Disengaged) |  Oil Pressure           |
|  Power Take-Off Clutch Control-On Position (Engaged)     |  Choke                  |

# FOREWORD

You are now the proud owner of a KUBOTA ZERO TURN MOWER. This machine is a product of KUBOTA's quality engineering and manufacturing. It is made of excellent materials and under a rigid quality control system. It will give you long, satisfactory service. To obtain the best use of your machine, please read this manual carefully. It will help you become familiar with the operation of the machine and contains many helpful hints about machine maintenance. It is KUBOTA's policy to utilize, as quickly as possible, every advance in our research. The immediate use of new techniques in the manufacturing of products may cause some small parts of this manual to become outdated. KUBOTA distributors and dealers will have the most up-to-date information. Please do not hesitate to consult them.



## SAFETY FIRST

This symbol, the industry's "Safety Alert Symbol", is used throughout this manual and on labels on the machine itself to warn of the possibility of personal injury. Read these instructions carefully. It is essential that you read the instructions and safety regulations before you attempt to assemble or use this unit.



**DANGER :** Indicates an imminently hazardous situation which, if not avoided, will result in death or serious injury.



**WARNING :** Indicates a potentially hazardous situation which, if not avoided, could result in death or serious injury.



**CAUTION :** Indicates a potentially hazardous situation which, if not avoided, could result in minor or moderate injury.

**IMPORTANT :** Indicates that equipment or property damage could result if instructions are not followed.

**NOTE :** Gives helpful information.

# CONTENTS

<b>SAFE OPERATION</b> .....	<b>5</b>
<b>SERVICING OF MACHINE</b> .....	<b>15</b>
<b>SPECIFICATIONS</b> .....	<b>16</b>
SPECIFICATION TABLE.....	16
<b>IMPLEMENT LIMITATIONS</b> .....	<b>18</b>
<b>INSTRUMENT PANEL AND CONTROLS</b> .....	<b>19</b>
INSTRUMENT PANEL, SWITCHES AND HAND CONTROLS.....	19
MOWER.....	20
<b>MOWER MOUNTING</b> .....	<b>21</b>
MOUNTING THE MOWER DECK.....	21
ADJUSTING THE MOWER.....	22
DISMOUNTING THE MOWER DECK.....	22
<b>OPERATING THE ENGINE</b> .....	<b>23</b>
GETTING ON AND OFF THE MACHINE SAFELY.....	23
STARTING THE ENGINE.....	23
1. Throttle lever and choke knob.....	24
2. Key switch.....	25
STOPPING THE ENGINE.....	25
1. Engine stop (by manual).....	25
CHECK DURING OPERATING.....	26
1. Easy Checker™.....	26
2. Fuel gauge.....	26
3. Fuel pump.....	26
4. Hour meter.....	26
COLD WEATHER STARTING.....	27
WARMING UP THE ENGINE.....	27
1. Warm-up and transmission oil in the low temperature range.....	27
JUMP STARTING.....	27
<b>OPERATING THE MACHINE</b> .....	<b>29</b>
OPERATING A NEW MACHINE.....	29
1. Changing lubricating oil for new machine.....	29
2. Engine break-in.....	29
3. Machine break-in.....	29
OPERATING THE FOLDABLE ROPS.....	30
1. Folding the ROPS.....	30
2. Raising the ROPS to the upright position.....	31
3. Adjusting the foldable ROPS.....	31
STARTING THE MACHINE.....	31
1. Operator's seat.....	31
2. Seat belt.....	32
3. Hydraulic lift control pedal.....	32
4. Throttle lever.....	33
5. Parking brake pedal.....	33
6. Motion control lever.....	33
6.1 Stop position of the motion control lever.....	33
6.2 Operating position of the motion control lever.....	34
6.3 Re-start on slopes.....	35
STOPPING THE MACHINE.....	36
PARKING THE MACHINE.....	36



TRANSPORTING THE MACHINE.....	36
WORK LIGHT (OPTIONAL KIT).....	37
<b>OPERATING THE MOWER.....</b>	<b>38</b>
MOWING TIPS.....	38
ADJUSTING THE CUTTING HEIGHT.....	38
1. Cutting height reference chart.....	40
OPERATING THE MOWER.....	41
1. PTO lever.....	41
2. Starting the machine.....	41
<b>TIRES AND WHEELS.....</b>	<b>42</b>
TIRES.....	42
1. Inflation pressure.....	42
WHEELS.....	42
1. Removing the front caster wheels.....	42
2. Installing the front caster wheels.....	43
<b>MAINTENANCE.....</b>	<b>44</b>
SERVICE INTERVALS.....	44
PERIODIC SERVICE CHART LABEL.....	46
LUBRICANTS AND FUEL.....	47
<b>PERIODIC SERVICE.....</b>	<b>49</b>
OPENING THE HOOD, AND STEP.....	49
1. Hood.....	49
2. Step.....	49
RAISING AND LOWERING THE OPERATOR'S SEAT.....	49
OPENING THE LEVER GUIDE.....	50
LIFT-UP POINT.....	50
1. Front side:.....	50
2. Rear side:.....	51
DAILY CHECK.....	51
1. Checking the engine oil level.....	51
2. Checking the amount of fuel and refueling.....	52
3. Checking transmission fluid level.....	53
4. Checking and cleaning bonnet screen and air intake area to prevent overheating.....	53
5. Checking and cleaning bottom dust cover.....	54
6. Checking and cleaning area around engine to prevent overheating.....	54
7. Checking the tire pressure.....	55
7.1 Inflation pressure.....	55
8. Lubricating all grease fittings.....	55
9. Checking movable parts.....	56
EVERY 50 HOURS.....	56
1. Checking the engine start system.....	56
2. Checking the OPC system.....	57
3. Checking gear box oil level.....	57
4. Greasing.....	58
5. Oiling.....	59
EVERY 100 HOURS.....	60
1. Changing engine oil.....	60
2. Cleaning air cleaner primary element.....	60
3. Cleaning engine shroud panel.....	61
4. Cleaning engine oil cooler fins.....	62
5. Checking the fuel filter.....	63
6. Cleaning fuel filter bowl.....	64
7. Adjusting parking brake.....	65
7.1 Check brake spring.....	65
7.2 Check on the slope.....	66

8. Checking the battery condition .....	66
8.1 Charging the battery .....	67
8.2 Cleaning area around battery .....	68
9. Adjusting throttle cable .....	68
EVERY 150 HOURS .....	68
1. Changing gear box oil .....	68
EVERY 200 HOURS .....	69
1. Replacing the engine oil filter .....	69
2. Checking spark plug condition and gap .....	70
3. Replacing transmission oil filter (HST) .....	70
4. Adjusting the motion control lever pivot .....	71
5. Cleaning engine shroud .....	71
EVERY 400 HOURS .....	71
1. Changing transmission fluid and rear axle gear case oil (RH and LH) .....	71
2. Replacing hydraulic oil filter .....	72
3. Replacing fuel filter .....	73
EVERY 500 HOURS .....	73
1. Adjusting engine valve clearance .....	73
EVERY AFTER 1000 HOURS .....	73
1. Cleaning combustion chamber .....	73
EVERY 1000 HOURS OR EVERY 1 YEAR .....	73
1. Replacing air cleaner primary element and secondary element .....	73
EVERY 1 YEAR .....	73
1. Checking fuel lines .....	73
2. Checking hydraulic hose .....	73
3. Checking intake air line .....	74
4. Checking engine breather hose .....	74
5. Checking mower gear box oil seal .....	74
EVERY 2 YEARS .....	75
1. Replacing one way valve .....	75
EVERY 4 YEARS .....	75
1. Replacing hydraulic hoses .....	75
2. Replacing fuel lines .....	75
3. Replacing engine breather hose .....	75
4. Replacing mower gear box oil seal .....	75
5. Replacing intake air line .....	75
SERVICE AS REQUIRED .....	75
1. Replacing fuses .....	75
2. Checking and replacing blades .....	76
3. Replacing the mower belt .....	77
4. Bleeding fuel system .....	77
<b>ADJUSTMENT .....</b>	<b>78</b>
MOTION CONTROL LEVER .....	78
1. HST neutral .....	78
2. Motion control lever neutral position .....	78
3. Maximum speed (forward) .....	79
4. Motion control lever alignment .....	79
4.1 Checking the alignment .....	79
4.2 Aligning the motion control levers .....	79
MOWER DECK LEVEL .....	80
1. Anti-scalp rollers .....	80
2. Leveling the mower deck (side-to-side) .....	80
3. Leveling the mower deck (front-to-rear) .....	81
GENERAL TORQUE SPECIFICATION .....	83
TIGHTENING TORQUE CHART .....	84
<b>STORAGE .....</b>	<b>85</b>

STORING THE MACHINE .....	85
REMOVING THE MACHINE FROM STORAGE.....	85
1. Fuel.....	85
2. Inspecting and cleaning fuel filter bowl.....	86
<b>TROUBLESHOOTING .....</b>	<b>88</b>
ENGINE TROUBLESHOOTING .....	88
BATTERY TROUBLESHOOTING.....	90
MACHINE TROUBLESHOOTING .....	90
MOWER TROUBLESHOOTING.....	91
<b>ENGINE EMISSION RELATED INFORMATION .....</b>	<b>93</b>
<b>INDEX.....</b>	<b>94</b>

# SAFE OPERATION

Careful operation is your best insurance against an accident.

The owner/user can prevent and is responsible for accidents or injuries occurring to themselves, other people or property. Read and understand this manual carefully before operating the machine. All operators, no matter how much experience they may have had, must read and understand this and other related manuals before operating the machine or any implement attached to it. It is the owner's obligation to instruct all operators in safe operation.

If the operator(s) or mechanic(s) cannot understand the contents, it is the owner's responsibility to explain this material to them. This mowing machine is capable of amputating hands, feet and throwing objects. Failure to observe the following safety instructions could result in serious injury or death.

## BEFORE OPERATING THE MACHINE

Know your equipment and its limitations. Read all instructions in this manual before attempting to start and operate the machine.

### 1. General

- The zero turn mowing machine has different steering characteristics than other machines with a steering wheel and does not have a service brake pedal (but, has a parking brake pedal that can be used to stop the machine in an emergency). Normal slowing down and stopping is done with the motion control levers. Read and understand the operator's manual before operating the machine. Practice operating the machine at low engine speed in an unobstructed area without engaging the mower.
- Pay special attention to the safety labels on the machine itself.
- Do not operate the machine or any attachments while under the influence of alcohol, medication, controlled substances or when fatigued.
- Do not wear loose, torn, or bulky clothing around the machine. The clothing may catch on moving parts or controls, leading to the risk of an accident. Wear and use any additional safety items such as a hard hat, safety boots or shoes, eye and hearing protection, gloves and so on, as appropriate or required.
- Do not wear radio or music headphones while operating the machine.
- Do not operate the machine or any attachments while using or texting with a cellphone or any other electronic device.  
Safe operation requires your full attention.
- Carefully check the vicinity before operating machine or any implement attached to it. Clear the work area of objects (such as wires and rocks,) that might be picked up and thrown. Check for overhead clearance which may interfere with a grass catcher.
- Check parking brake and other mechanical parts for correct adjustment and wear. Replace worn or damaged parts promptly. Check the tightness of all nuts and bolts regularly.  
(See PERIODIC SERVICE on page 49 and ADJUSTMENT on page 78.)
- Keep all shields and guards in place. Replace any that are damaged or missing. Do not operate unless they are functioning properly.
- Before allowing other people to use your machine, explain how to operate and have them read this manual before operation.
- Do not allow any bystanders around or near machine during operation.
- Do not allow passengers, children or non-qualified operators on the machine at any time. The operator must remain in the machine seat throughout operation.
- In addition to the design and configuration of equipment, hazard control and accident prevention are dependent upon the awareness, concern and prudence of personnel involved in the operation, transport, maintenance of the equipment.
- Evaluate the terrain to determine what accessories and attachments are needed to properly and safely perform the job. Keep the machine and attachments in good operating condition and keep safety devices in place and in proper working condition. Do not operate unless they are functioning properly.
- Do not modify the machine. Unauthorized modification may affect the function of the machine, which may result in personal injury.
- Use only implements approved by KUBOTA. Use proper ballast on the front or rear of the machine to reduce the risk of upsets. Follow the safe operating procedures specified in the manuals of the equipment.
- Keep your machine clean. Accumulations of dirt, grease, and trash can contribute to fires and lead to personal injury.
- The exhaust gas from the muffler is very hot. To prevent fire, do not expose dry grass, mowed

## SAFE OPERATION

grass, oil and any other combustible materials to the exhaust gas. Use a spark arrester where required. Keep the engine and muffler clean all the times.

### 2. ROPS

- The ROPS is an integral and effective safety device.
- KUBOTA recommends the use of a roll-over protective structure (ROPS) and seat belt in almost all applications. This combination will reduce the risk of serious injury or death, should the machine be upset.
- The machine is equipped with a foldable ROPS, which may be temporarily folded down only when absolutely necessary for areas with height constraints.
- There is no operator protection provided by the ROPS in the folded position. For operator safety you must set the ROPS in the upright and locked position and put on the seat belt for all other operations.
- If the ROPS is loosened or removed for any reason, make sure that all parts are reinstalled correctly before operating the machine.
- Never modify or repair a ROPS because welding, bending, drilling, grinding, or cutting may weaken the structure.
- If any structural member of the ROPS is damaged, replace the entire structure at your local KUBOTA Dealer. Any alterations to a ROPS must be approved by the manufacturer.
- Check the area to be mowed and never fold down a foldable ROPS in areas where there are slopes, drop-offs or water.
- Check carefully for overhead clearances (such as branches, doorways and electrical wires) before driving under any objects and do not contact them.
- Keep the ROPS in safe operating condition by periodically and thoroughly inspecting for damage and keeping all mounting fasteners tight.
- Always use the seat belt when the ROPS is upright. Do not use the seat belt if the ROPS is down or if there is no ROPS. Check the seat belt regularly and replace if frayed or damaged. Be certain that the seat belt can be released quickly in the event of an emergency.

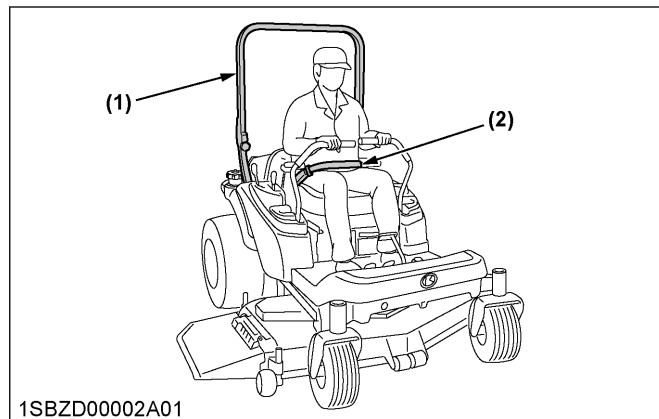

1SBZD00002A01

- (1) ROPS
- (2) Seat belt

## OPERATING THE MACHINE

### 1. Starting to operate the machine

- Always sit in the operator's seat when starting the engine or operating levers or controls.
- Before starting the engine make sure that the motion control levers are in neutral lock, the parking brake is applied, hood is closed and the power take-off (PTO) is disengaged (OFF).
- Do not start the engine by shorting across starter terminals. The machine may start in gear and move if the normal starting circuitry is bypassed.
- Do not operate or idle the engine in a non-ventilated area. Carbon monoxide gas is colorless, odorless, and deadly.
- Do not start the engine while tilting deck.
- Check before each use that the operator presence control (OPC) system is functioning correctly. Test the safety systems. (See Checking the engine start system on page 56 and Checking the OPC system on page 57.) Do not operate unless they are functioning correctly.
- Check all fluids before starting.

### 2. Working the machine

- Do not turn sharply when driving at high speed.
- To avoid tip-over accidents, slow down when turning on uneven terrain or before stopping.
- Do not operate near ditches, holes, embankments, or other terrain, which may collapse under the machine's weight. The risk of machine tip-overs increases when the ground is loose or wet.
- Park the machine on a firm and level surface. Before you get off, apply the parking brake, place the motion control levers in their neutral lock positions, disengage the PTO, lower all attachments to the ground, turn off the engine, and remove the key.

# SAFE OPERATION

- Watch where you are going at all times. Watch for and avoid obstacles. Be alert at curbs, shrubs, near trees, and other obstructions and hidden hazards. Obstacles can damage machine (fuel hoses, wire harness, and so on).
- Know what is behind you before backing up. Look to the rear before and when backing. Do not mow while in reverse. Operate in reverse with the blades engaged only when absolutely necessary and make sure the area immediately behind you is clear of obstructions or holes, and small children.
- When working in groups, always let others know what you are doing ahead of time.
- Do not drive the machine on streets or highways. Watch for traffic when you cross roads or operate near roads.
- Be aware of the mower discharge direction and do not point it at anyone.  
Never operate with the discharge deflector raised, removed or altered.
- When using any attachments, never direct discharge material toward bystanders. Do not allow people or pets near the attachments while in operation.  
Do not mow when bystanders are present in the mowing area.
- To reduce fire hazards, keep the engine exhaust area free of grass or leaves.
- Be sure that the rotating blades and the engine are stopped and the key is removed before placing hands or feet near blades, cleaning blockages or unclogging the discharge deflector.
- Keep hands and feet away from the cutting units.  
Shut the engine off and wait for all movement to stop before removing the grass catcher or unclogging the discharge deflector.
- Watch the temperature gauge and maintain all screens to avoid overheating conditions.
- Always inspect the mower for damage after striking a foreign object. Repair or replace any damaged parts before restarting.
- Operate during daylight or in bright artificial light.
- Never raise the deck with the blades running.  
Disengage the PTO and stop the blades from rotating if not mowing.

## 3. Safety for children

Tragic accidents can occur if the operator is not alert of the presence of children. Children are attracted to the machine and mowing activity.

- Never assume that children will remain where you last saw them.
- Keep children out of the mowing area and under the watchful care of another responsible adult.
- Be alert and turn the machine off if children enter the area.

- Before and when backing, look behind and down for small children.
- Never carry children. There is no safe place for them to ride. They may fall off and be seriously injured or interfere with safe machine operation.
- Never allow children to operate the machine, even under adult supervision.
- Use extra care when approaching blind corners, shrubs, trees, or other obstructions that might hide children from sight.
- Do not mow in reverse. Operate in reverse with the blades engaged only when it is absolutely necessary and make sure that the area to the rear is clear of children before doing so.

## 4. Operators, age 60 years and older

Data indicates that operators, age 60 years and older, are involved in a large percentage of machine-related injuries. These operators must evaluate their ability to operate the machine safely enough to protect themselves and others from serious injury.

## 5. Operating on slopes

Slopes are a major factor related to loss-of-control and tip-over accidents, which can result in severe injury or death. All slopes require extra caution.

If you cannot back up the slope or if you feel uneasy on it, do not mow it.

If the engine stops when operating on a slope, apply the parking brake immediately to prevent machine runaway.

### Do

- To avoid tip-over accidents, operate across slopes, not up and down. Stay off hills and slopes too steep for safe operation.
- Remove obstacles such as rocks and tree limbs, and so on.
- Stay alert for holes in the terrain and other hidden hazards. Keep away from drop-offs. Uneven terrain could overturn the machine. Tall grass can hide obstacles.
- Follow the manufacturer's recommendations for wheel weight or counterweights to improve stability.
- Keep all movement on slopes slow and gradual. Do not make sudden changes in speed or direction.
- Avoid starting or stopping on a slope. If tires lose traction, disengage the PTO and proceed slowly straight down the slope.
- Reduce the speed and exercise extreme caution on slopes and in sharp turns to prevent tip-over accidents or loss of control.
- Use special caution when changing direction on slopes. Slow down, and use extra caution when changing direction on a slope.

# SAFE OPERATION

## Do not

- Do not turn on slopes unless necessary. If necessary, turn uphill slowly and gradually.
- Do not mow near drop-offs, ditches, or embankments. The mower could suddenly turn over if a wheel is over the edge of cliff or ditch, or if an edge caves in.
- Do not mow on wet grass. Reduced traction could cause sliding and loss of control.
- Do not try to stabilize the machine by putting your foot on the ground.
- Do not use grass catcher on steep slopes.
- Do not start or stop suddenly when going uphill or downhill. Avoid sudden start and stops on slopes.
- Never "freewheel". Do not let the machine travel downhill with motion control levers at the neutral lock position or in neutral.
- Do not operate the machine without the mower deck installed.

## 6. Stopping the machine

- Park the machine on level ground.
- Make sure that the machine and all attachments have come to a complete stop before you get off.
- Before you get off, apply the parking brake, place the motion control levers in their neutral lock positions, disengage the PTO, lower all attachments to the ground, turn off the engine, and remove the key.
- Do not park the machine on dry grass or leaves.

## 7. Using the PTO

- Before installing or using PTO-driven equipment, read the manufacturer's manual and review the safety labels attached to the equipment.
- Wait until all moving components have completely stopped before connecting, disconnecting, adjusting, cleaning, or servicing any PTO-driven equipment.
- Use the PTO with KUBOTA approved attachments.

The speed of PTO:

**ZG327A-AU:** 2530 rpm at 3200 engine rpm

## 8. Using the lift link

- Use lift link only with authorized attachments designed for lift link usage.

## TRANSPORTING THE MACHINE

- Disengage power to attachment(s) when transporting or not in use.
- Do not tow this machine. Use a suitable truck or trailer when transporting on public roads.

- Use extra care when loading or unloading the machine into a trailer or truck.
- This machine is not allowed to be used on public roads.

## SERVICING AND STORAGE

### 1. Servicing the machine

- Before servicing, park the machine on a firm, level surface and apply the parking brake. Remove the key to prevent an accidental start-up.
- Allow the machine time to cool before touching the engine, muffler, radiator and so on.
- Always stop the engine before refueling. Avoid spills and overfilling. If fuel is spilled, do not attempt to start the engine and avoid creating any source of ignition until fuel vapors have dissipated.

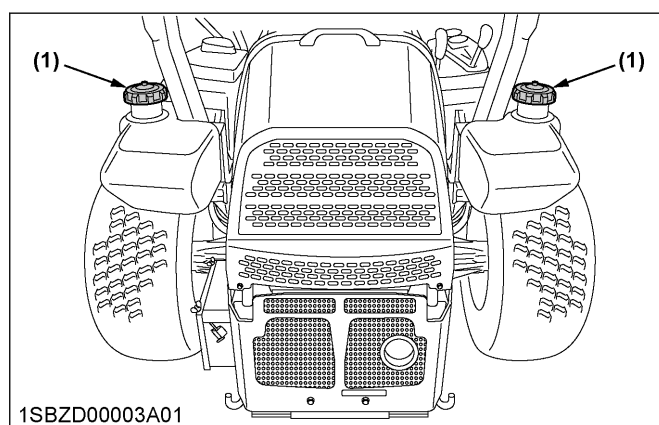

(1) Fuel tank cap

- Use extra care when handling gasoline fuels. They are flammable.
  1. Use only an approved container.
  2. Do not remove the fuel cap or refuel with the engine running. Allow the engine to cool before refueling. Do not smoke while refueling or when standing near fuel.
  3. Do not refuel the machine indoors and always clean up spilled fuel or oil.
  4. Do not store the machine or fuel container inside where there is an open flame, such as in a water heater.
- Do not smoke when working around battery or when refueling. Keep all sparks and flames away from battery and fuel tank.

A battery, especially when charging, will give off hydrogen and oxygen gases, which can explode and cause serious personal injury.



# ! SAFE OPERATION



1SFRT00004A01

- Before “jump starting” a dead battery, read and observe all of the instructions.
- Disconnect the battery or remove the spark plug wire before making any repairs. Disconnect the negative terminal first and the positive last. Reconnect the positive first and negative last. Wear protective clothing and use insulated tools.

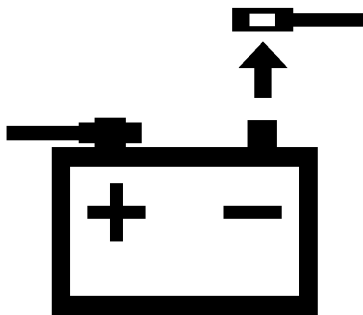

1SHWZ00038A01

- Do not use or charge the refillable type battery if the fluid level is below the [LOWER] (lower limit level) mark. Otherwise, the battery component parts may prematurely deteriorate, which may shorten the battery's service life or cause an explosion. Check the fluid level regularly and add distilled water as required so that the fluid level is between the [UPPER] and [LOWER] levels.
- Keep a first aid kit and fire extinguisher handy at all times.

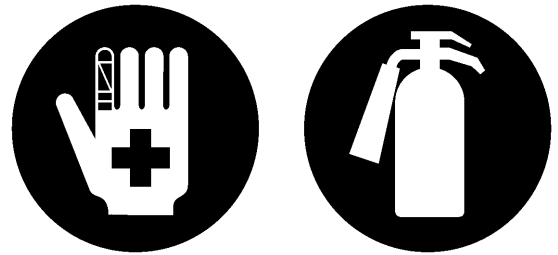

1SHWZ00039A01

- Do not attempt to mount a tire on a rim unless qualified to do so and all proper safety precautions are followed. Never allow untrained personnel to service the machine.
- Always maintain the correct tire inflation pressure. Do not inflate tires above the recommended pressure shown in the operator's manual.

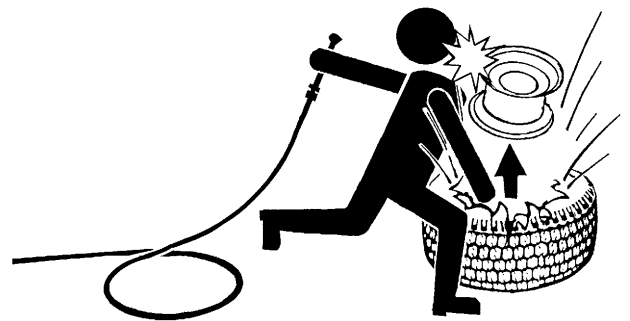

1SFRT00006A01

- Provide adequate support when changing wheels.
- Make sure that wheel nuts and bolts have been tightened to the specified torque.
- Escaping hydraulic fluid under pressure has sufficient force to penetrate the skin causing serious personal injury. Before disconnecting lines, be sure to relieve all pressure. Before applying pressure to the system, make sure all connections are tight and that lines, pipes, and hoses are not damaged.



1LLEE00009A01

# ! SAFE OPERATION

- Fluid escaping from pinholes may be invisible. Use a piece of cardboard or wood to search for suspected leaks: do not use hands. Use safety goggles or other eye protection.

If you get injured by escaping fluid, see a medical doctor at once. Serious infection or reaction will result if proper medical treatment is not administered immediately. This fluid can produce gangrene or severe allergic reaction.

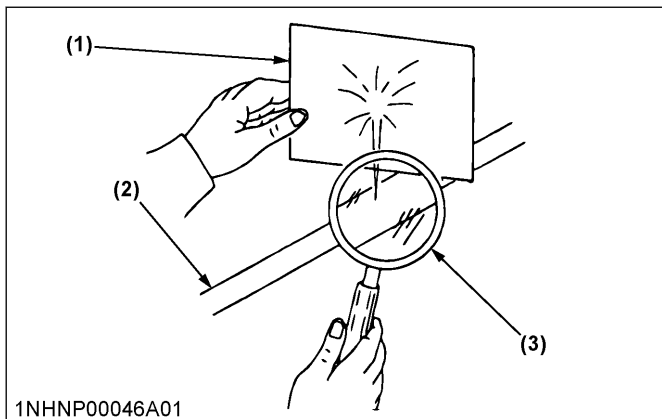

(1) Cardboard (3) Magnifying glass  
(2) Hydraulic line

- Do not make adjustments or repairs with the engine running.
- Keep the machine free of grass, leaves, or other debris build-up.
- Do not change the engine governor setting or overspeed the engine.
- Do not run the machine inside a closed area.
- Mower blades are sharp and can cut your hands. Wrap the blade(s) or wear gloves, and use extra caution when servicing them.
- Keep nuts and bolts, especially blade attachment bolts, tight and keep equipment in good condition.
- Never tamper with safety devices. Check their operation for proper function regularly.
- Waste products such as used oil, fuel, coolant, brake fluid, and batteries can harm the environment, people, pets and wildlife. Please dispose of the waste products properly.
- Do not use beverage containers for waste fluids or other products. Someone, particularly children, may drink them by mistake.
- Securely support the machine or any machine elements with stands or suitable blocking before working underneath. For your safety, do not rely on hydraulically supported devices as they may leak down, suddenly drop or be accidentally lowered.
- Consult your local recycling center or KUBOTA Dealer to learn how to recycle or get rid of waste products.
  - A material safety data sheet (MSDS) provides specific details on chemical products, physical and health hazards, safety procedures, and emergency response techniques. The seller of

the chemical products used with your machine is responsible for providing the MSDS for that product upon request.

## 2. Storage

- Keep the machine and supply of fuel in locked storage and remove the ignition key to prevent children or others from playing or tampering with them.
- To avoid sparks from an accidental short circuit, always disconnect the battery's ground cable (-) first and reconnect it last.

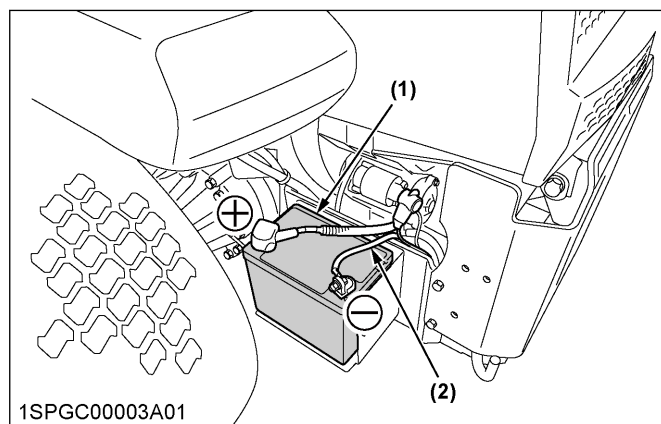

(1) Battery (+) Positive terminal  
(2) Ground cable (-) Negative terminal

- To avoid the danger of exhaust fume poisoning, do not operate the engine indoors without adequate ventilation.
- To reduce fire hazards, clean the machine thoroughly before storage. Dry grass and leaves around the engine and muffler may ignite.

## SAFETY LABELS

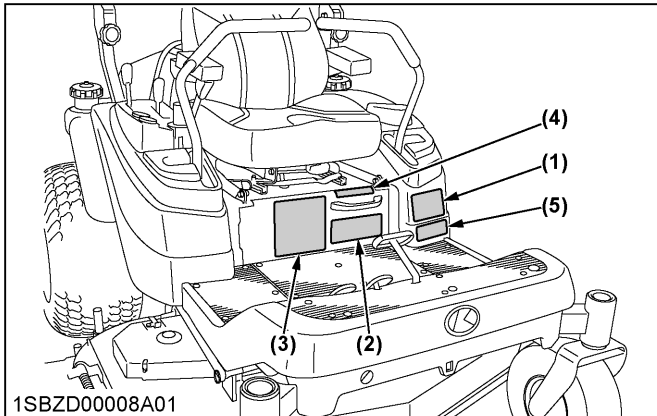

(1) Part No. K3181-6585-1

**! WARNING**

**TO AVOID SERIOUS INJURY OR DEATH**

1. Park the machine on level ground.
2. If necessary to park on an incline.
  - ① Stop the machine.
  - ② Apply the parking brake.
  - ③ Stop the engine.
 If you stop the engine on an incline without applying the parking brake, the machine could move and runaway.
3. If the engine stops suddenly during operation, apply the parking brake immediately to prevent machine runaway.

(2) Part No. K3181-6584-1

**! WARNING**

**TO AVOID SERIOUS INJURY OR DEATH**

1. Mow across slopes-Not up and down.
2. Use extreme caution when operating on slopes.
3. Loss of traction may occur when operating on slopes.
4. Drive slowly on slopes.
5. Do not operate on wet slopes.
6. Avoid sudden starts.
7. Execute turns slowly.

(4) Part No. K3441-6569-1

**! WARNING**

When Engine is running, do not open this cover.

(5) Part No. K3284-6569-1

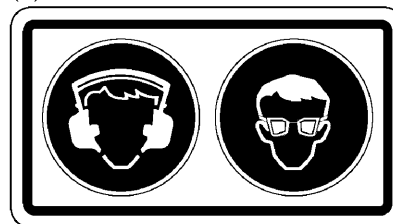

(3) Part No. K3441-6582-1

**! WARNING**

**TO AVOID SERIOUS INJURY OR DEATH**

1. Read and understand the operator's manual before operation.
2. Do not operate this machine unless you are trained.
3. Before allowing other people to use the machine, have them read the operator's manual.
4. Check the tightness of all nuts and bolts regularly.
5. Before starting the engine, make certain that everyone is at a safe distance from the machine, PTO is disengaged and motion control levers are in neutral lock.
6. Remove objects that could be thrown by the blade.
7. Do not operate the machine when children and/or others are around.
8. Do not carry children or others on the machine at any time.
9. Before dismounting, disengage PTO clutch, lower the implement, place motion control levers in neutral lock position, set the parking brake, stop the engine and remove the key.
10. Keep safety devices (guards, shields and switches) in place, and working.
11. To reduce the fire hazard, keep the exhaust clear of dry grass, dry leaves or other combustible materials.
12. This machine is not for street or highway use.
13. Securely support the machine and implement before working underneath.

# ⚠️ SAFE OPERATION

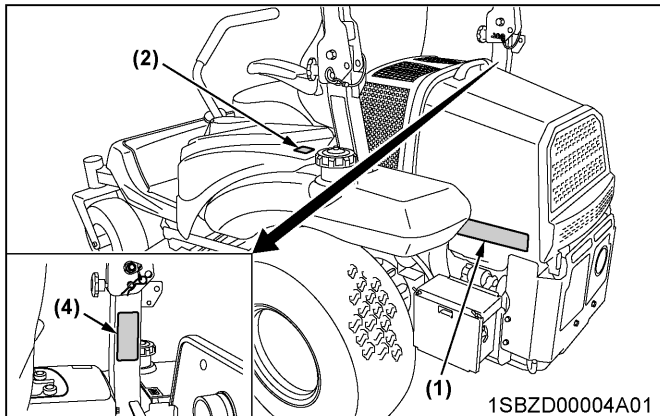

(1) Part No. K3181-6583-2

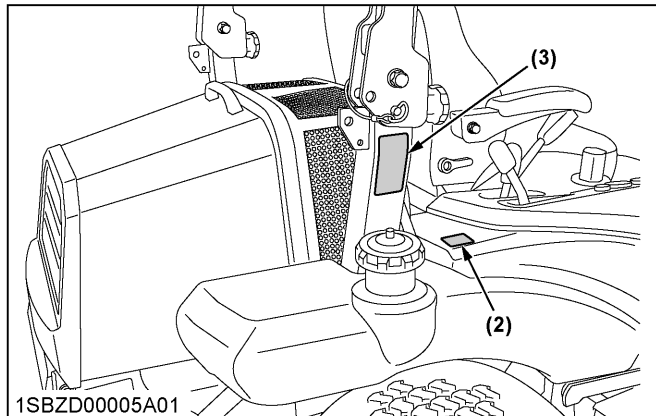



## ⚠️ DANGER

**TO AVOID POSSIBLE INJURY OR DEATH FROM A MACHINE RUNAWAY.**

1. Do not start engine by shorting across starter terminals or bypassing the safety start switch. Machine may start in gear and move if normal starting circuitry is bypassed.
2. Start engine only from operator's seat with motion control levers in neutral lock position and PTO OFF. Never start engine while standing on the ground.

(2) Part No. K3282-6587-1

Gasoline fuel only      No fire



GASOLINE  
GASOLINA

---

REFUEL BOTH  
TANKS EVENLY  
RELLENE AMBOS  
TANQUES AL  
MISMO NIVEL

(3) Part No. K3441-6566-1

**⚠️ WARNING**

Never modify or repair a ROPS because welding, grinding, drilling, or cutting any portion may weaken the structure.

**⚠️ WARNING**

**TO AVOID PERSONAL INJURY WHEN RAISING OR FOLDING ROPS:**

1. Set parking brake and stop engine.
2. Remove any obstruction that may prevent raising or folding of the ROPS.
3. Do not allow any bystanders.
4. Always perform function from a stable position at the rear of the tractor.
5. Hold the top of the ROPS securely when raising or folding.
6. Make sure all pins are installed and locked.

(4) Part No. K3181-6563-1

**⚠️ WARNING**



**TO AVOID PERSONAL INJURY OR DEATH FROM ROLL-OVER:**

1. Keep Roll-Over Protective Structures (ROPS) in the upright and locked position.
2. Fasten SEAT BELT before operating.





**THERE IS NO OPERATOR PROTECTION WHEN THE ROPS IS IN THE FOLDED POSITION.**

1. Check the operating area and fold the ROPS only when absolutely necessary.
2. Do not wear SEAT BELT if ROPS is folded.
3. Raise and lock ROPS as soon as vertical clearance allows.
4. Read ROPS related instructions and warnings.

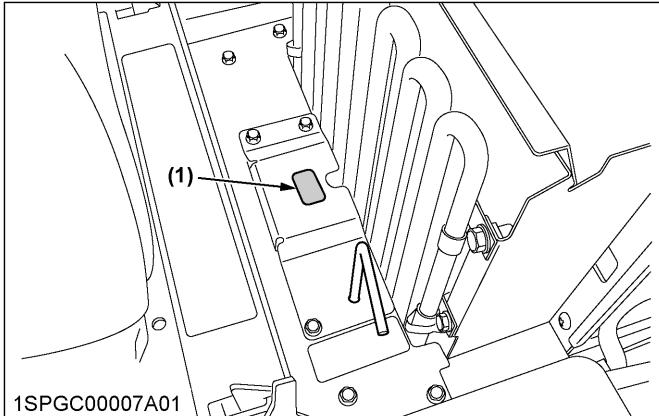
# ! SAFE OPERATION

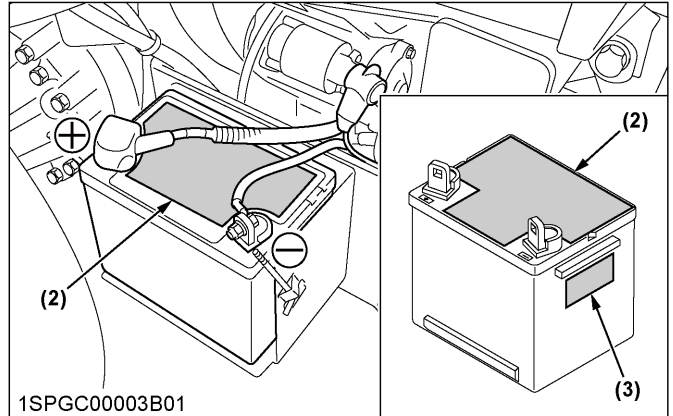
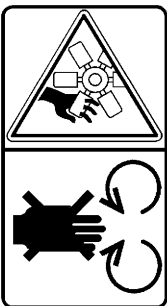

(1) Part No. K3111-6591-1  
Do not get your hands close to fan belt.



(3) Part No. K2601-9616-2

**PROPOSITION 65 WARNING:** Battery posts, terminals and related accessories contain lead and lead compounds, chemicals known to the State of California to cause cancer and reproductive harm. Batteries also contain other chemicals known to the State of California to cause cancer. **WASH HANDS AFTER HANDLING.**

**ADVERTENCIA DE LA PROPUESTA 65:** Los postes de batería, terminales y accesorios relacionados pueden contener plomo y compuestos de plomo, productos químicos conocidos en el estado de California por causar cáncer y daños a la reproducción. Las baterías también contienen otros productos químicos conocidos en el estado de California por causar cáncer. **LÁVESE LAS MANOS DESPUÉS DE LA MANIPULACIÓN.**

**AVERTISSEMENT PROPOSITION 65 :** Les bornes de batterie, les prises et les accessoires associés contiennent du plomb et des composés de plomb, des produits chimiques connus dans l'Etat de la Californie pour causer le cancer et des effets nocifs sur la reproduction. Les batteries contiennent aussi d'autres produits chimiques connus dans l'Etat de la Californie pour causer le cancer. **SE LAVER LES MAINS APRES MANIPULATION.**



(2) Part No. K1221-6113-3

<b>! DANGER/POISON !</b>		<b>! PELIGRO/VENENO !</b>	
<p><b>SHIELD EYES.</b> EXPLOSIVE GASES CAN CAUSE BLINDNESS OR INJURY. <b>PROTÉGEZ LES YEUX.</b> LES GAZ EXPLOSIFS PEUVENT BLESSER OU RENDRE AVEUGLE. <b>PROTEJA LOS OJOS.</b> LOS GASES EXPLOSIVOS PUEDEN CAUSAR DAÑOS O CEGUERA.</p>	<p><b>NO ÉVITER</b></p> <ul style="list-style-type: none"> <li>• SPARKS</li> <li>• FLAMES</li> <li>• SMOKING</li> <li>• LES ÉTINCELLES</li> <li>• LES FLAMMES</li> <li>• DE FUMER</li> <li>• CHISPAS</li> <li>• FLAMAS</li> <li>• CIGARROS</li> </ul>	<p><b>SULFURIC ACID CAN CAUSE BLINDNESS OR SEVERE BURNS.</b> <b>L'ACIDE SULFURIQUE PEUT CAUSER LA CÉCITÉ OU DES BRÛLURES GRAVES.</b> <b>ÁCIDO SULFÚRICO PUEDA CAUSAR CEGUERA O QUEMADURAS FUERTES.</b></p>	<p><b>FLUSH EYES IMMEDIATELY WITH WATER. GET MEDICAL HELP FAST. RINCEZ LES YEUX À L'EAU IMMÉDIATEMENT. CONSULTEZ UN MÉDECIN RAPIDEMENT. ENJUAGUE LOS OJOS INMEDIATAMENTE CON AGUA. ACUDA RÁPIDO CON EL MÉDICO.</b></p>
<p>If battery is put into service after date shown, charge for minimum of 1 hour at 6-10 amps.</p>	<p><b>KEEP OUT OF THE REACH OF CHILDREN. TENIR HORS DE LA PORTEE DES ENFANTS. ALÉJESE DEL ALCANCE DE LOS NIÑOS.</b></p>	<p><b>READ ALL INSTRUCTIONS. LIRE TOUTES LES INSTRUCTIONS. LEA TODAS LAS INSTRUCCIONES.</b></p>	<p><b>DO NOT OPEN BATTERY! DO NOT TIP! NE PAS OUVRIR LA BATTERIE! NE PAS RENVERSER. ¡NO ABRIR LA BATERÍA! NO VOLTEAR.</b></p>
<p>Si la mise en service de cette batterie s'effectue après la date indiquée, veuillez recharger de 5 à 10 ampères pendant 1 heure.</p> <p>Si la batería es puesta en servicio después de la fecha que se muestra, cárguela durante un mínimo de 1 hora a 6-10 amperes.</p>	<p><b>WARNING: RISK OF FIRE, EXPLOSION OR BURNS. DO NOT DISASSEMBLE OR INCINERATE. NOT RECOMMENDED FOR INVERTED USE. FOLLOW PROPER CHARGING INSTRUCTIONS.</b></p>	<p><b>AVERTISSEMENT : RISQUE D'INCENDIE, D'EXPLOSION OU DE BRÛLURES. NE PAS DEMONTER OU INCINERER. NON RECOMMANDÉ POUR UNE UTILISATION INVERSEE. SUIVEZ ATTENTIVEMENT LES INSTRUCTIONS DE CHARGEMENT.</b></p>	<p><b>ADVERTENCIA: RIESGO DE INCENDIO, EXPLOSIÓN O QUEMADURAS. NO DESMONTE NI INCINERE. NO RECOMENDADO PARA USO INVERTIDO. SIGA LAS INSTRUCCIONES CORRECTAS DE CARGA.</b></p>
<p>Dist. by/por/par: EPM Products, 9108 Yellowbrick Rd. Baltimore, MD 21237 4-4264 610-682-6361</p>	<p><b>12V</b></p> <p>Made in USA with US and Imported materials Fabricado en los EE. UU con materiales estadounidenses e importados. Fabricado aux États-Unis avec des matériaux américains et importés</p>	<p><b>NO. /N° K1221-61153</b></p> <p>CCA (A) @ 0°F (-18°C) <b>300</b></p> <p>REF. 20 HR Ah <b>25</b></p>	

1SPGC00082A01enUS

# ! SAFE OPERATION

RCK60P

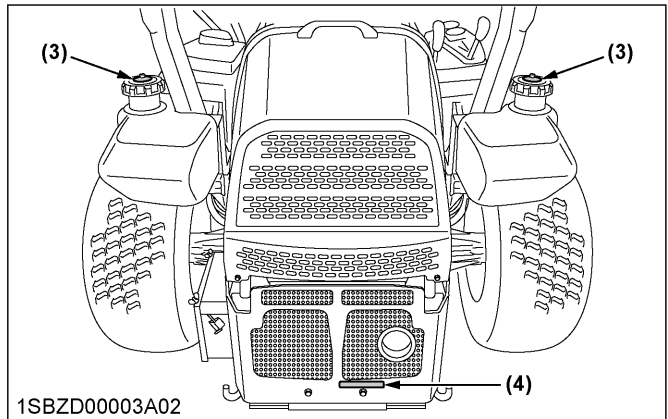
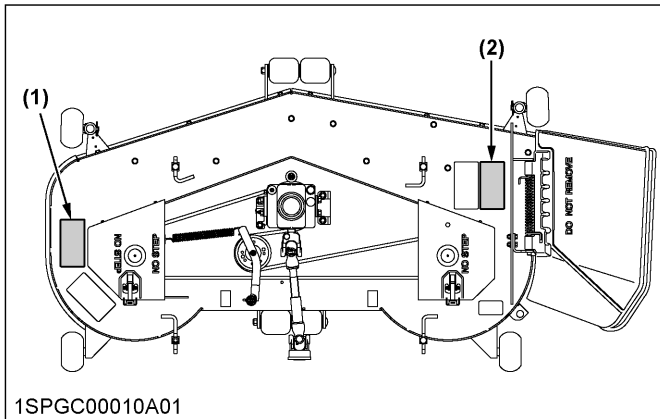

(1) Part No. K5681-7312-2

(2) Part No. K5681-7311-2



(3) Part No. K3281-2491-2

(4) Part No. K3441-6532-1

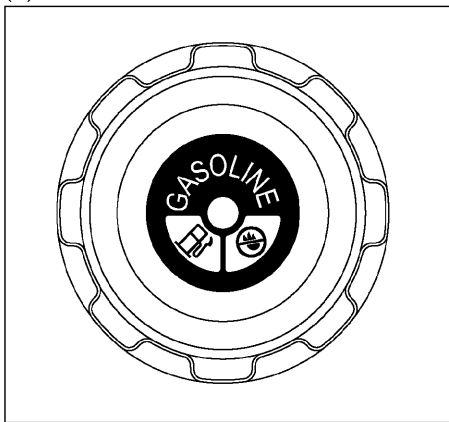

1SBZD00036A01enUS

## CARE OF SAFETY LABELS

- Keep safety labels clean and free from obstructing material.
- Clean safety labels with soap and water, and dry with a soft cloth.
- Replace damaged or missing safety labels with new labels from your local KUBOTA Dealer.
- If a component with safety label(s) attached is replaced with a new part, make sure new label(s) is (are) attached in the same location(s) as the replaced component.
- Attach new safety labels by applying on a clean dry surface and pressing any bubbles to the outside edge.

# SERVICING OF MACHINE

After reading this manual thoroughly, you will find that you can do some of the regular maintenance yourself. Your dealer has knowledge of your new machine and has the desire to help you get the best performance and the most value from it.

However, when in need of parts or major service, be sure to consult your local KUBOTA Dealer. When in need of parts, be prepared to give your dealer the product identification number (PIN), and the ROPS, engine and mower serial numbers.

Locate the PIN and serial numbers now, and record them in the space provided.

Date of purchase	
Name of dealer	

To be filled in by purchaser

	Type	PIN/Serial number
Machine		
ROPS		
Engine		
Mower		

To be filled in by purchaser

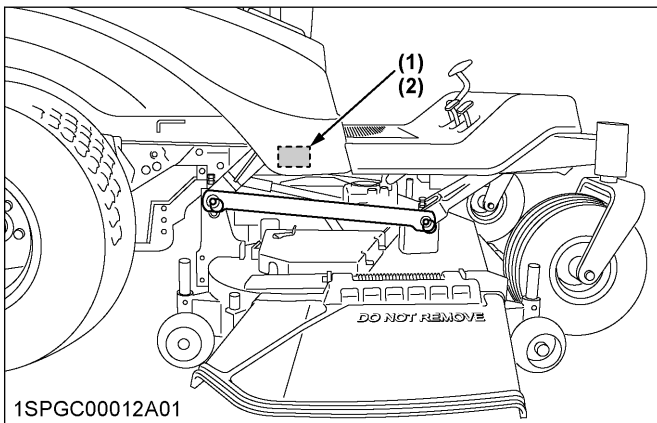

- (1) Machine identification plate
- (2) Product identification number

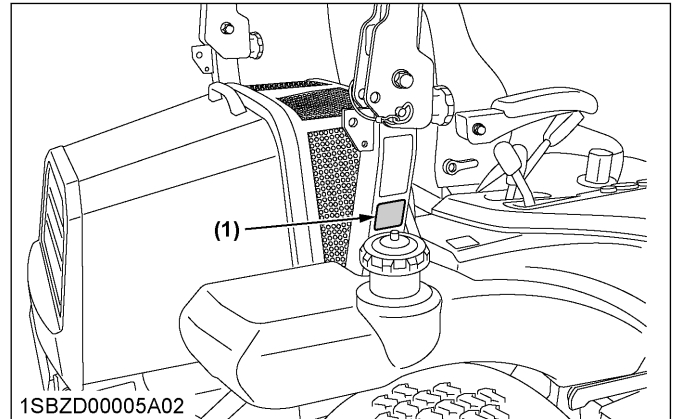

- (1) ROPS serial number

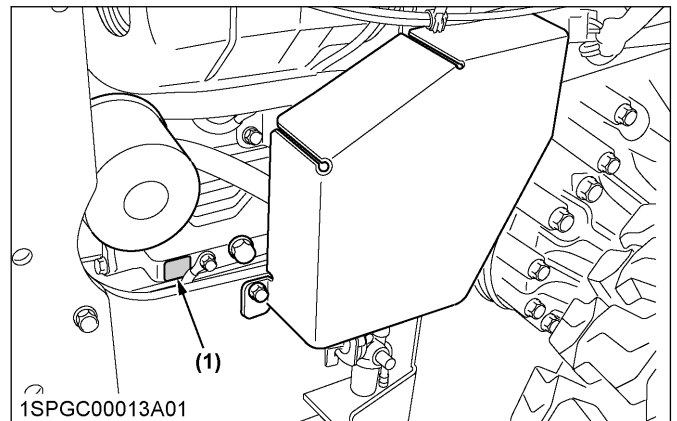

- (1) Engine serial number

## RCK60P

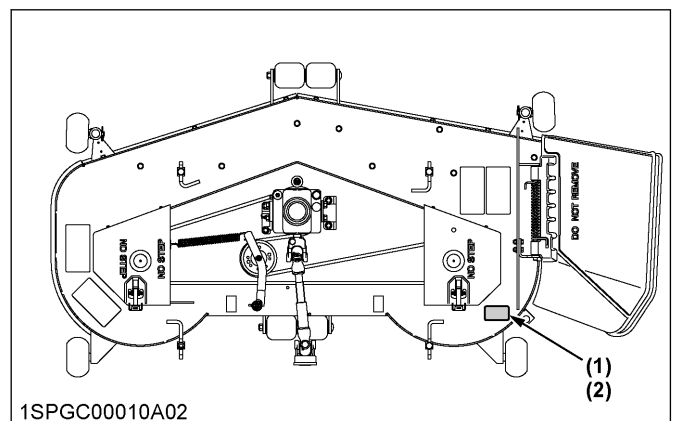

- (1) Mower identification plate
- (2) Mower serial number



# SPECIFICATIONS

## SPECIFICATION TABLE

Model			ZG327PA-AU	
Engine	Model		<b>KGZ770-MA1</b>	
	Maximum engine power (gross)	kW (HP)	19.4 (26) *1	
	Type		Air-cooled gasoline engine	
	Number of cylinders		2 (V-Twin)	
	Bore and stroke	mm (in.)	84.2 × 69 (3.31 × 2.72)	
	Total displacement	cm <sup>3</sup> (cu. in.)	768 (46.9)	
	Rated revolution	rpm	3200	
	Fuel		Automobile unleaded or regular gasoline	
	Starter		Electric starter with battery	
	Lubrication		Full pressure lubrication	
	Cooling		Forced air cooled	
	Battery		U1L-10 (12 V, RC: 22 min, CCA: 300, CA: 365)	
	Capacities	Fuel tank	L (U.S.gals.)	48 (12.7)
Engine crankcase (with filter)		L (U.S.qts.)	2.0 (2.1)	
Transmission case including rear axle gear case		L (U.S.qts.)	12.1 (12.8) *2	
Dimensions	Overall length		mm (in.) 2230 (87.8)	
	Overall width without mower deck		mm (in.) 1460 (57.5)	
	Overall height	With ROPS up-right	mm (in.)	1915 (75.4)
		With ROPS folded	mm (in.)	1555 (61.2)
	Wheelbase		mm (in.) 1410 (55.5)	
	Min. ground clearance		mm (in.) 130 (5.12) with 60"	
	Tread	Front	mm (in.)	975 (38.4)
Rear		mm (in.)	1150 (45.3)	
Weight (with mower deck)		kg (lbs.)	710 (1565) with 60" (Side)	
Traveling system	Tires	Front	15 × 6.0 - 6 (Non flat tire) Rib	
		Rear	26 × 12.0 - 12 (4PR) Turf	
	Traveling speeds	Forward	mph (km/h)	0 to 10.6 (0 to 17.0) *3
		Reverse	mph (km/h)	0 to 5.3 (0 to 8.5) *3
	Steering			2 - hand levers
	Transmission			2 - HST with gear
	Parking brake			Wet multi disk/foot applied, released
	Min. turning radius	mm (in.)		0 (0)
PTO	Revolution		1 speed (2530 rpm at 3200 engine rpm)	
	Drive system		Shaft drive, KUBOTA 10 tooth involute spline	
	Clutch type		Wet multi disks	
	PTO brake		Wet single disk	

Specifications and design subject to change without notice.

- \*1 Power (HP) specifications for individual gasoline engine models are rated pursuant to society of automobile engineers (SAE) J1940 based on gross output testing performed in accordance with SAE J1995 without the air cleaner and muffler.
- \*2 Oil amount when the oil level is at the upper level.
- \*3 At 3200 engine rpm

<b>Model</b>			<b>RCK60P-327Z</b>	
PRO commercial deck (fabricated deck)	Suitable machine		<b>ZG327PA-AU</b>	
	Mounting method		Quick joint, parallel linkage	
	Adjustment of cutting height		Dial gauge	
	Cutting width	mm (in.)	1524 (60.0)	
	Cutting height	mm (in.)	25 to 127 (1.0 to 5.0)	
	Weight (approximation)	kg (lbs.)	138 (304)	
	Blade spindle speed	r/s (rpm)	56.0 (3360) *1	
	Blade tip velocity	m/s (fpm)	92.0 (18100) *1	
	Blade length	mm (in.)	523 (20.6)	
	Number of blades		3	
	Dimensions	Total length	mm (in.)	1002 (39.4)
		Total width	mm (in.)	1911 (75.2)
Total height		mm (in.)	358 (14.1)	

\*1 Engine maximum rpm

# IMPLEMENT LIMITATIONS

The KUBOTA Machine has been thoroughly tested for proper performance with implements sold or approved by KUBOTA.

Use with implements below may result in malfunctions or failures of the machine, damage to other property and injury to the operator or others.

- Implements which are not sold or approved by KUBOTA
- Implements which exceed the maximum specifications listed below, or
- Implements which are otherwise unfit for use with the KUBOTA Machine

Any malfunctions or failures of the machine resulting from use with improper implements are not covered by the warranty.

Unit	Maximum loading weight		Implement weight $W_1$	Maximum total weight
	Front axle $W_f$	Rear axle $W_r$		
ZG327PA-AU	170 kg (375 lbs.)	815 kg (1797 lbs.)	200 kg (440 lbs.)	985 kg (2172 lbs.)

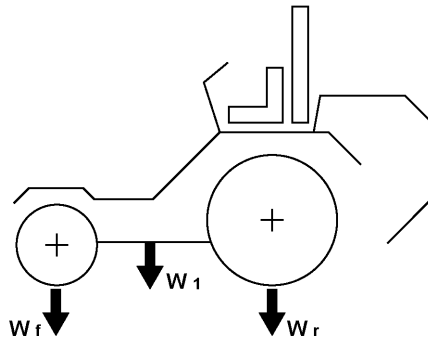

1SFRT00011A01

# INSTRUMENT PANEL AND CONTROLS

## INSTRUMENT PANEL, SWITCHES AND HAND CONTROLS

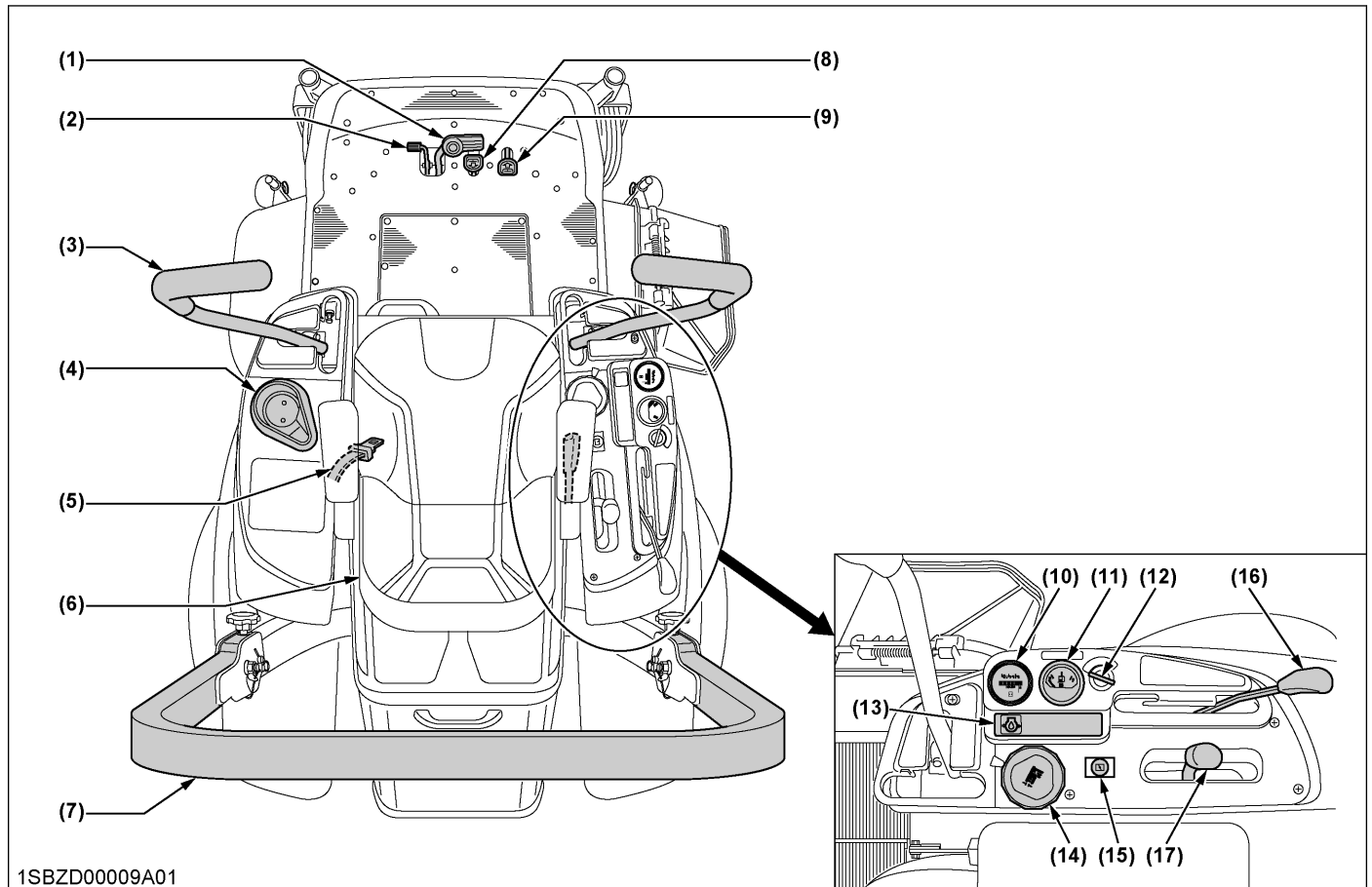

1SBZD00009A01

**Illustrated contents**

(1) Parking brake pedal.....	23	(8) Hydraulic lift control pedal (DOWN).....	32
Parking brake pedal.....	33	(9) Hydraulic lift control pedal (UP).....	32
(2) Parking brake lock pedal.....	23	(10) Hour meter.....	26
Parking brake lock pedal.....	33	(11) Fuel gauge (LH tank only).....	26
(3) Motion control lever.....	23	(12) Key switch.....	25
Motion control lever.....	33	(13) Easy Checker™.....	26
(4) Cup holder.....		(14) Cutting height control dial.....	38
(5) Seat belt.....	32	(15) Choke knob.....	24
(6) Operator's seat.....	31	(16) PTO lever.....	41
(7) ROPS.....	30	(17) Throttle lever.....	33

# MOWER

## RCK60P

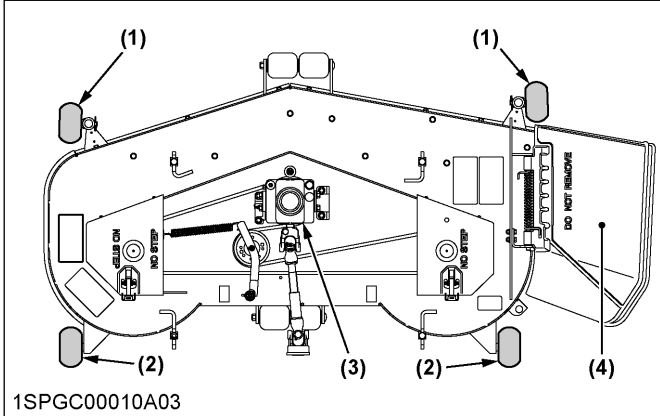

(1) Anti-scalp roller (front, pin shift type) .....	38
(2) Anti-scalp roller (rear, bolt shift type) .....	38
(3) Gear box .....	
(4) Discharge deflector .....	29
Discharge deflector .....	41

# MOWER MOUNTING

## MOUNTING THE MOWER DECK

### WARNING

To avoid serious injury or death:

- Park the machine on a firm and level surface.
- Apply the parking brake.
- Stop the engine and remove the key.

1. Before mounting the mower deck, raise the lift links to the full up position.
2. Adjust the cutting height control dial to 1 in. position.
3. Go backward so that right and left rear tires would be on the board 40 mm (1.57 in.) high.

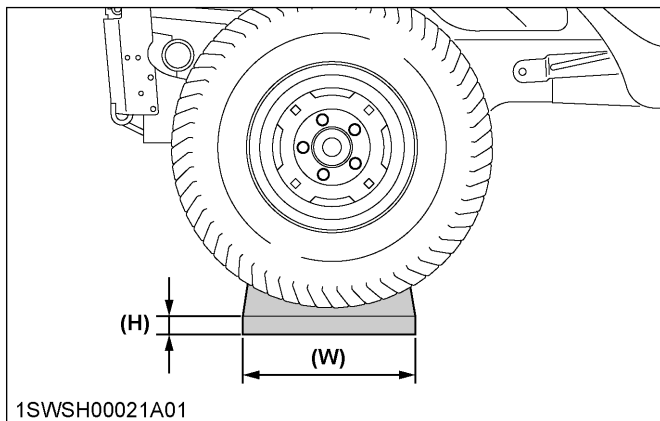

(H) 40 mm (1.57 in.)  
(W) 300 mm (11.8 in.)

### IMPORTANT :

- Use a board more than 300 mm (11.8 in.) wide and 1400 mm (55.1 in.) long.
- Make sure that right and left rear tires are firm on the board.

4. Change the direction of the front tires as shown in the figure.

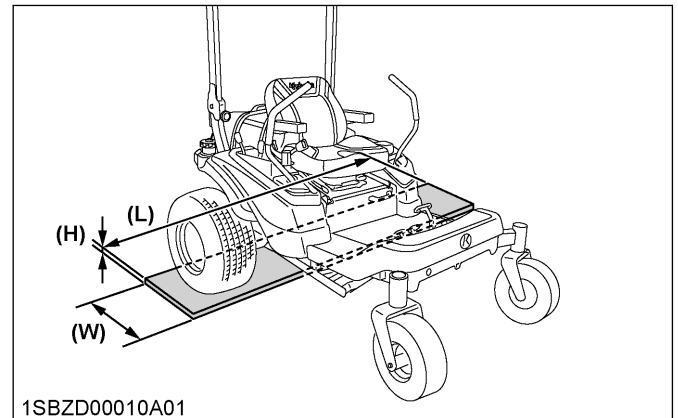

1SBZD00010A01  
(H) 40 mm (1.57 in.)  
(W) 300 mm (11.8 in.)  
(L) 1400 mm (55.1 in.)

5. Place the mower deck at the left side of the machine.

### NOTE :

- For easy installation set the anti scalp roller as shown below.

### RCK60P: 2 places front (rear, bolt shift type)

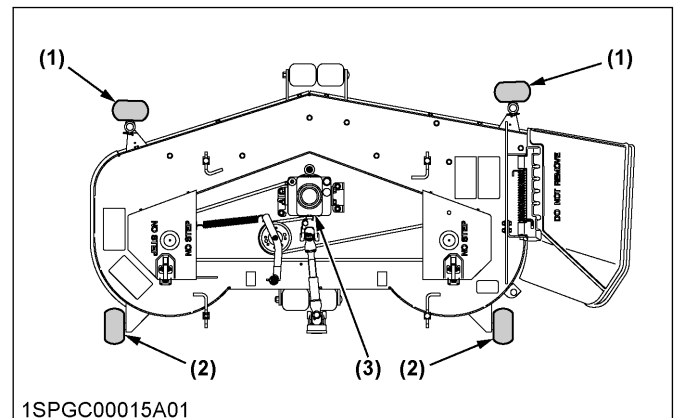

(1) Anti scalp roller (pin shift type)  
(2) Anti scalp roller (bolt shift type)  
(3) Gear box

6. Slide the mower deck under the machine, and make sure that the mower gear box is placed properly in the center of the machine.
7. Depress the hydraulic lift control pedal (DOWN) and pull down the lift links.

8. Attach the lift links to the mower deck with attaching hardware.

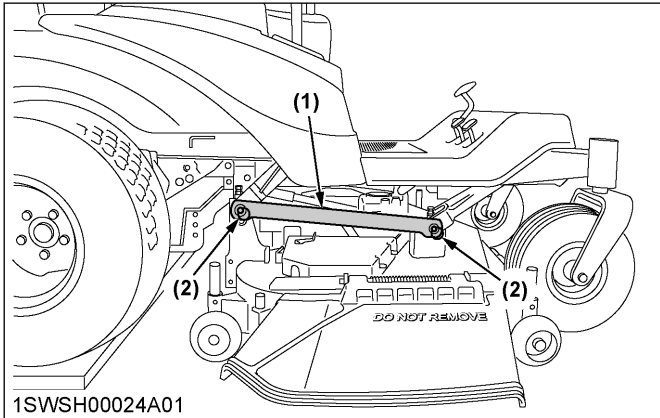

- (1) Lift link  
 (2) Clevis pin, plain washer, snap ring

9. Install universal joint.  
 Pull back the coupler of the universal joint.  
 Push the universal joint onto the PTO shaft until the coupler locks.

**IMPORTANT :**

- Tug the universal joint backward and forward to make sure it is locked securely.

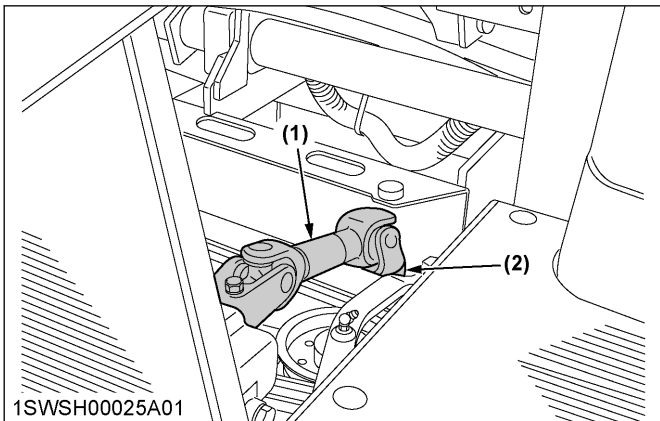

1SWSH00025A01

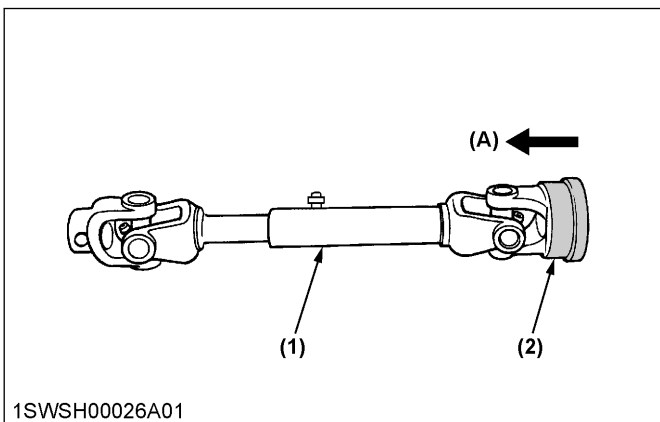

1SWSH00026A01

- (1) Universal joint  
 (2) Coupler  
 (A) "PULL"

10. After mounting the mower, check the mower level. If necessary, adjust the mower level and anti-scalp rollers.

**ADJUSTING THE MOWER**

(See OPERATING THE MOWER on page 38 and ADJUSTMENT on page 78.)

**DISMOUNTING THE MOWER DECK**

For dismantling the mower deck, reverse the above procedures.



# OPERATING THE ENGINE

## WARNING

To avoid serious injury or death:

- Read and understand the safe operation section.
- Understand the safety labels located on the machine.
- To avoid the danger of exhaust fume poisoning, do not operate the engine indoors without proper ventilation.
- Never start the engine while standing on the ground. Start the engine only from the operator's seat.

Details regarding safe operation can be found in a different section.

(See SAFE OPERATION on page 5.)

## GETTING ON AND OFF THE MACHINE SAFELY

Do not step on either side of the mower deck when you get on and get off the machine. When you get on and off the machine use LH side and step over the mower deck.

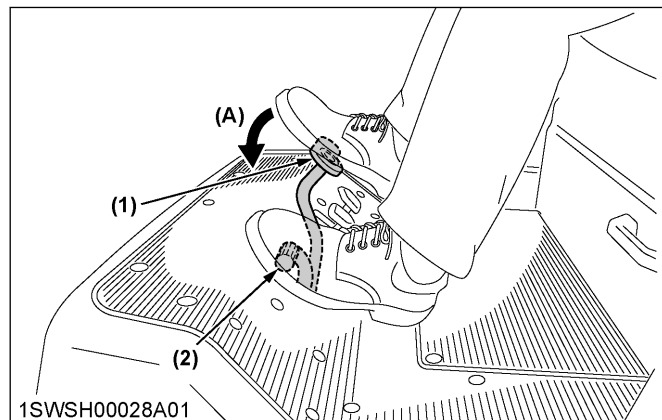
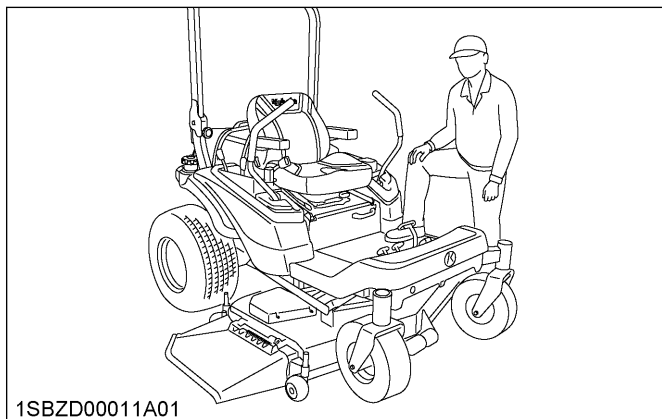

- (1) Parking brake pedal (A) "DEPRESS"  
(2) Parking brake lock pedal

### To release the parking brake:

Depress the brake pedal and release it slowly with your right foot without pressing the parking brake lock pedal.

3. Place the PTO lever in the "DISENGAGED" (OFF) position.

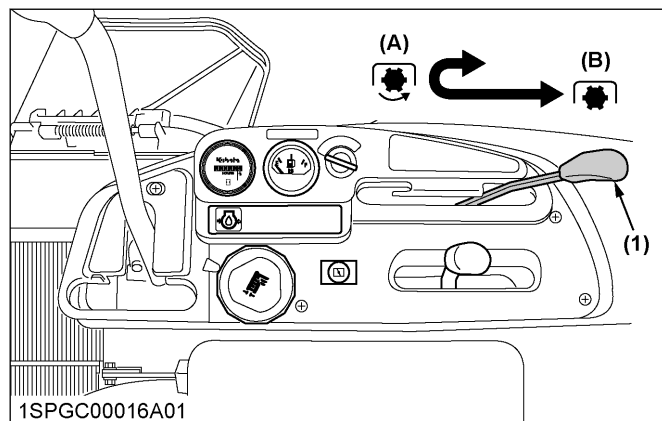

- (1) PTO lever (A) "ENGAGED" (ON)  
(B) "DISENGAGED" (OFF)

## STARTING THE ENGINE

1. Sit on the operator's seat.
2. Apply the parking brake.

### To apply the parking brake:

- a. Depress the parking brake pedal firmly with your right foot and the parking brake lock pedal simultaneously with your left foot.
- b. Then release the parking brake pedal while holding the parking brake lock pedal down.

- Place the motion control levers in the "NEUTRAL LOCK" position.

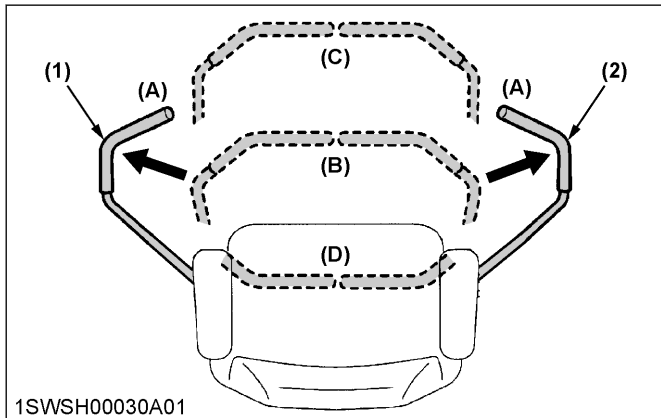

- |                               |                             |
|-------------------------------|-----------------------------|
| (1) Motion control lever (LH) | (A) "NEUTRAL LOCK" position |
| (2) Motion control lever (RH) | (B) "NEUTRAL" position      |
|                               | (C) "FORWARD"               |
|                               | (D) "REARWARD"              |

- Set the throttle lever as follows.
  - If the engine is cold: Pull the choke knob out.
  - If the engine is warm: Place the throttle control lever midway between the "SLOW" and the "FAST" positions.

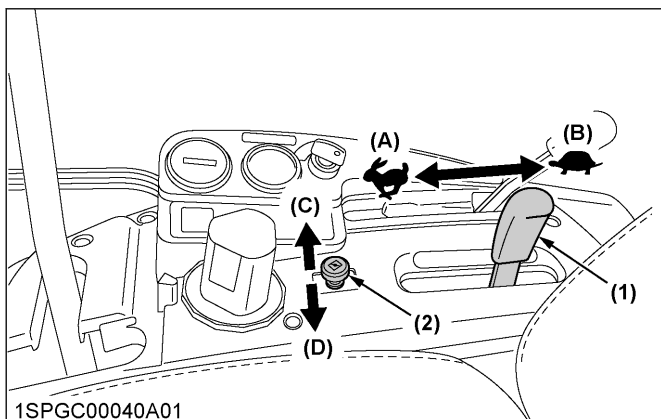

- |                    |                             |
|--------------------|-----------------------------|
| (1) Throttle lever | (A) "FAST"                  |
| (2) Choke knob     | (B) "SLOW"                  |
|                    | (C) Pull out: "ON" position |
|                    | (D) Push in: "OFF" position |

- Insert the key into the key switch and turn clockwise 1 notch. Make sure the Easy Checker™ lights are "ON". (See Key switch on page 25.)

**WARNING**

To avoid serious injury or death:

- Do not depress the hydraulic lift control pedal. When the engine is off, depressing the hydraulic lift control pedal (UP or DOWN) will lower the implement.

- Turn the key switch to the "START" position and release the key to the "ON" position when the engine starts.

**IMPORTANT :**

- Do not use starting fluid or ether.
- To protect the battery and the starter, make sure that the starter is not continuously turned for more than 10 seconds. If the engine does not start, allow 60 seconds cool down period between starting attempts.
- If the starter does not turn the engine over, shut off the starter immediately. Do not make further attempts to start the engine until the condition is corrected. Do not jump start using another battery. Consult your local KUBOTA Dealer.
- Do not turn the key switch while the engine is running.
- When the temperature is below 0 °C (32 °F), run the engine at medium speed to warm up the lubricant of the engine and transmission for at least 10 minutes. If the machine is operated before the lubricant is warm enough, the machine life will be shortened.
- Do not operate the machine under full load until it is sufficiently warmed up 2 or 3 minutes for temperature above 0 °C (32 °F).
- When the ambient temperature is less than -15 °C (5 °F), remove the battery from the machine and store it somewhere warm until next operation.

- Make sure that the Easy Checker™ lights have gone off. If the light is still on, immediately stop the engine and check the remedy following the instruction. (See CHECK DURING OPERATING on page 26.)
- Warm up the engine by running at medium speed.

**1. Throttle lever and choke knob**

Pulling the throttle lever backward decreases the engine speed and pushing it forward increases the engine speed.

**For a cold engine**

Always pull the choke knob out to the "ON" position to start the engine in cold conditions. Gradually return the choke control to the "OFF" position after the engine starts and warms up. The engine/equipment may be operated during the warmup period, but it may be necessary to leave the choke partially on until the engine warms up.

**For a warm engine**

Always push the choke knob in to the "OFF" position after the engine starts.

## 2. Key switch

**IMPORTANT :**

- Because of the start interlocks, the engine may not be started except when the PTO clutch is “*DISENGAGED*” (OFF), the parking brake lock pedal is applied, motion control levers are in “*NEUTRAL LOCK*” position, and the operator is sitting in the seat.

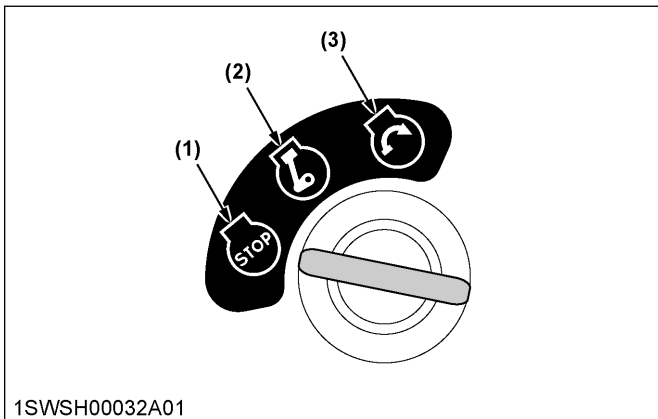

**(1) OFF**

The position where the key can be inserted into or removed from the key switch. When the key is turned to this position, the engine shuts off.

**(2) ON**

The engine keeps running.

**(3) START**

Apply the parking brake and turn the key switch to this position to start the engine.

## STOPPING THE ENGINE

- After slowing the engine to half speed, turn the key switch to the “OFF” position.
- Remove the key.
- Do not leave the key switch “ON” (key in the “ON” position) as the battery will discharge when the engine is not running.
- Apply the parking brake.
- Turn the carburetor fuel valve to the [STOP] (CLOSE) position.

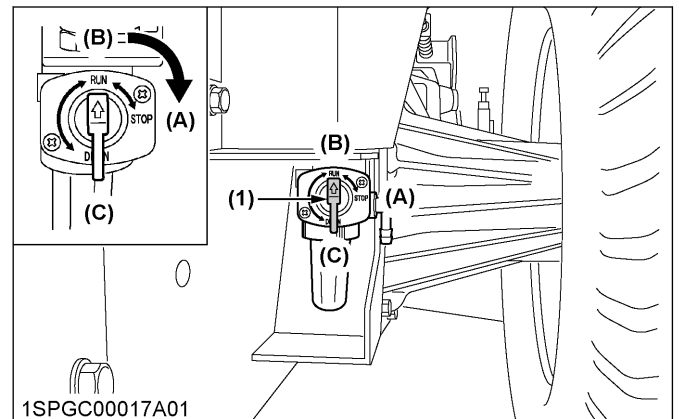

- (1) Carburetor fuel valve
- (A) [STOP] (CLOSE)  
 (B) [RUN] (OPEN)  
 (C) [DRAIN]

**IMPORTANT :**

- Do not stop the engine when the machine is on an incline for a long time. The engine oil may go into the carburetor and the muffler through the valve system.
- Place the throttle control lever in the half speed position to help prevent the engine from backfiring before stopping the engine.

## 1. Engine stop (by manual)

The engine stops when the key switch is turned off. If the engine does not stop, make sure the motion control levers are in “NEUTRAL LOCK” position, the PTO lever is “OFF”, the mower lowered to the ground, apply the parking brake, and confirm it is set, then carefully get off the machine. Turn the carburetor fuel valve to [STOP] (CLOSE) position and wait until the engine stops. Then contact your local KUBOTA Dealer immediately.

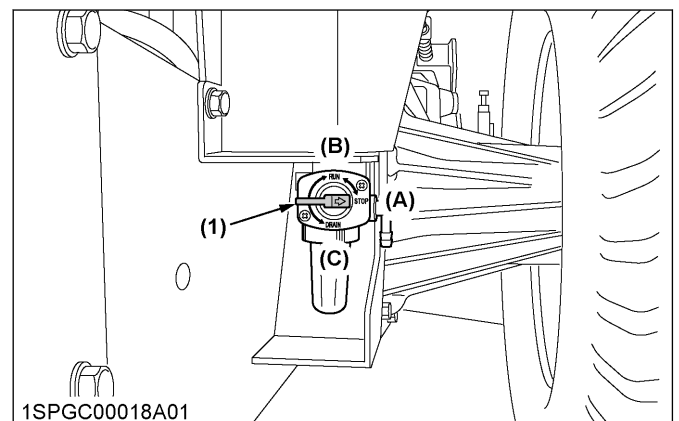

- (1) Carburetor fuel valve
- (A) [STOP] (CLOSE)  
 (B) [RUN] (OPEN)  
 (C) [DRAIN]

**! WARNING**  
 To avoid serious injury or death:

- Do not operate the machine until the engine stop system is repaired.

## CHECK DURING OPERATING

### IMPORTANT :

Immediately stop the engine if:

- The engine suddenly slows down or accelerates.
- Unusual noises suddenly occur.
- Exhaust fumes suddenly become discolored.

While operating, make the following checks to see that all the parts are functioning normally:

- Easy Checker™ on page 26

### 1. Easy Checker™

If the warning lamps of the Easy Checker™ come on during operation, immediately stop the engine, and find the cause as shown below.

Never operate the machine while Easy Checker™ lamp is on.

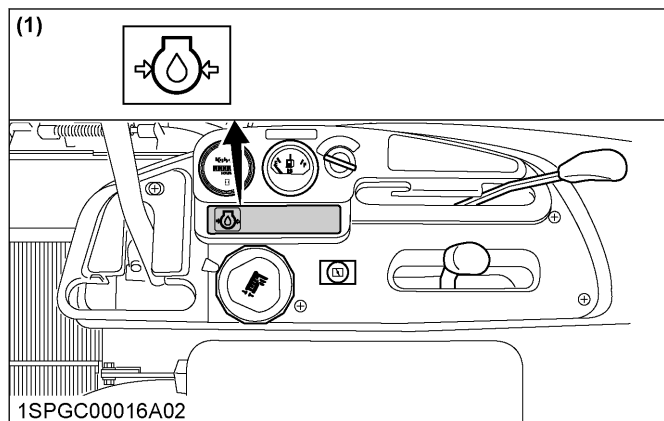

#### (1) Engine oil pressure

If the oil pressure in the engine goes below the prescribed level, the warning lamp in the Easy Checker™ will come on.

If this should happen during operation, stop the engine immediately and check level of engine oil. (See Checking gear box oil level on page 57.)

### 2. Fuel gauge

1. The fuel gauge shows the amount of fuel left in the LH tank.

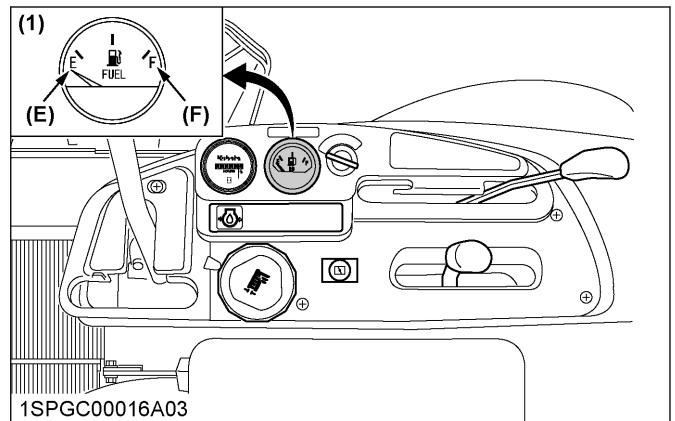

- (1) Fuel gauge (E) "EMPTY" (F) "FULL"

2. Refuel both the fuel tanks evenly.
3. If there is an amount gap between the LH and RH tanks, the fuel in the bigger-amount tank will be consumed first. Fuel in both the tanks will be consumed at the same time after the fuel levels of both the tanks become the same.

### IMPORTANT :

- Fill the fuel tank only to bottom of the filler neck.
- Fill the fuel on a level ground.
- Be careful not to empty the fuel tank. Otherwise air may enter the fuel system. Should this happen, the system should be bled. (See Bleeding fuel system on page 77.)
- Only fill with gasoline containing less than 10% ethanol content.

### 3. Fuel pump

This fuel pump has a limit drive function.

### NOTE :

- When the key is in the "OFF" position: It does not work.
- When you turn the key clockwise one notch, before the engine starts: It works for about 15 seconds.
- Keep the key in this position, before the engine starts. It will stop working after 15 seconds. And to reset the timer, keep the key in the "OFF" position for about 60 seconds.
- When the engine is running: It works normally.

### 4. Hour meter

This meter gives readings for the hours the machine has been operated.

**NOTE :**

- **As the hour meter works electrically, it starts to work when the key switch is turned to “ON”, regardless of the engine running or not.**

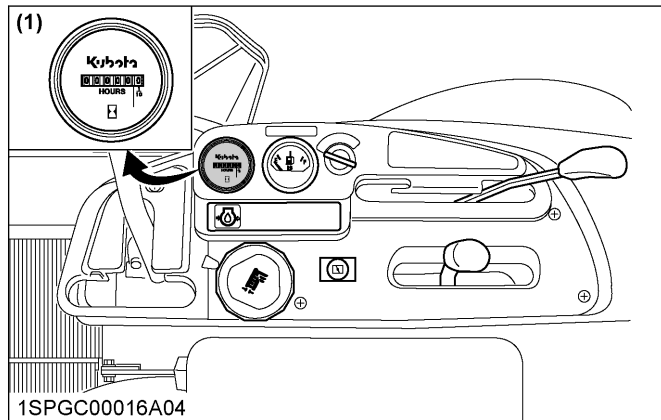

(1) Hours meter

## COLD WEATHER STARTING

If the ambient temperature is below 0 °C (32 °F) and the engine is very cold, start it in the following manner:

1. Pull the choke knob out.
2. Turn the key switch to the “START” (🔑) position.
  - Operate the starter 5 seconds.
  - If the engine does not start, wait 10 seconds.
  - Repeat this procedure until the engine starts.
3. When the engine starts, release the key to the “ON” (🔑) position.
4. Place the throttle lever midway between the “SLOW” and the “FAST” positions.

## WARMING UP THE ENGINE

### ⚠️ WARNING

To avoid serious injury or death:

- **Be sure to apply the parking brake during warm-up.**

For 5 minutes after the engine start-up, allow the engine to warm up without applying any load. This is to allow oil to reach every part of the engine. If load is applied to the engine without this warm-up period, problems such as seizure, breakage or premature wear may appear.

### 1. Warm-up and transmission oil in the low temperature range

Hydraulic oil serves as transmission oil. In cold weather conditions, the oil may be cold with increased viscosity. This can cause delayed oil circulation or abnormally

low hydraulic pressure for some time after engine start-up. This, in turn, can result in trouble in the hydraulic system or damage to the hydraulic clutch.

To prevent this from happening warm up the engine at about 50% of rated rpm according to the following table.

Ambient temperature	Warm-up time requirement
Higher than 0 °C (32 °F)	Approximately 5 minutes
-10 to 0 °C (14 to 32 °F)	5 to 10 minutes
-20 to -10 °C (-4 to 14 °F)	10 to 15 minutes
Below -20 °C (-4 °F)	More than 15 minutes

**IMPORTANT :**

- **Do not operate unless the engine is well warmed up. If operation is attempted while the engine is still cold, the hydraulic mechanism will not function properly and its service life will be shortened.**
- **If noises are heard after the hydraulic control lever has been activated and the implement is lifting, the hydraulic mechanism is not adjusted properly. Unless corrected, the unit will be damaged. Contact your local KUBOTA Dealer for adjustment.**

## JUMP STARTING

### ⚠️ WARNING

To avoid serious injury or death:

- **Battery gases can explode. Keep cigarettes, sparks, and flames away from the battery.**
- **If the machine battery is frozen, do not jump start the engine.**
- **Do not connect the other end of the negative jumper cable to the negative terminal of the machine battery.**

When jump starting the engine, observe the following instructions to start the engine safely:

1. Bring a helper vehicle with a battery of the same voltage as the disabled machine within easy cable reach.

**IMPORTANT :**

- **The vehicles must not touch.**
2. Apply the parking brakes of both vehicles and put the shift levers in the neutral position. Shut the engine off.
  3. Put on safety goggles and rubber gloves.
  4. Ensure that vent caps are securely in place (if equipped).

## OPERATING THE ENGINE

---

5. Attach the red clamp to the positive (red, (+) or pos.) terminal of the dead battery and clamp the other end of the same cable to the positive (red, (+) or pos.) terminal of the helper battery.
6. Clamp the other cable to the negative (black, (-) or neg.) terminal of the helper battery.
7. Clamp the other end to the engine block or the frame of the disabled machine as far from the dead battery as possible.
8. Start the helper vehicle and let its engine run for a few moments. Start the disabled machine.
9. Disconnect the jumper cables in the exact reverse order of attachment (steps 7, 6 and 5).

Connect cables in numerical order.

Disconnect in reverse order after use.

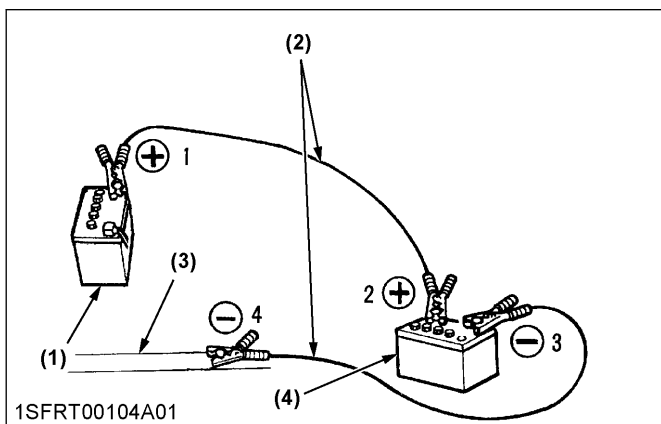

- (1) Dead battery  
(2) Jumper cables  
(3) Engine block or frame  
(4) Helper battery

### IMPORTANT :

- This machine has a 12 volt negative (-) ground starting system.
- Use only same voltage for jump starting.
- Use of a higher voltage source on the machine could result in severe damage to the machine electrical system.

Use only a matching voltage source when "jump starting" a low or dead battery.

# OPERATING THE MACHINE

## OPERATING A NEW MACHINE

How a new machine is operated and maintained will determine the operating life of the machine.

A new machine just off the factory production line has been tested, but the various parts are not accustomed to each other, so care should be taken to operate the machine for the first 50 hours at a slower speed and avoid excessive work or operation until the various parts become “*broken-in*”. The manner in which the machine is handled during the “*breaking-in*” period greatly affects the life of your machine. Therefore, to obtain the maximum performance and the longest operating life of the machine, it is very important to properly break-in your machine. In handling a new machine, the following precautions should be observed.

### 1. Changing lubricating oil for new machine

The lubricating oil is especially important in the case of a new machine. The various parts are not “*broken-in*” and are not accustomed to each other. Small metal grit may develop during the operation of the machine and this may wear out or damage the parts. Therefore, care should be taken to change the lubricating oil a little earlier than it would ordinarily be required.

Details regarding change interval hours can be found in a different section.

(See SERVICE INTERVALS on page 44.)

### 2. Engine break-in

After the first 50 hours of operation, change the engine oil and filter.

(See EVERY 100 HOURS on page 60 and EVERY 200 HOURS on page 69.)

### 3. Machine break-in

After the first 400 hours of operation, change the transmission fluid.

(See EVERY 400 HOURS on page 71.)

After the first 50 hours of operation, change the oil filter cartridge.

(See EVERY 200 HOURS on page 69.)

- Do not operate the mower without the discharge deflector in the down position.

### WARNING

To avoid serious injury or death:

- The machine relies upon the engine driven transmission for speed, direction, and motion control. If the engine is not running, the machine cannot be driven or controlled. If the engine stops when operating on a slope, apply the parking brake immediately to prevent a machine runaway.
- Do not allow anyone other than the driver to ride on the machine.
- Do not drive the machine close to the edges of ditches or banks which may collapse under the weight of the machine, especially when the ground is loose or wet.
- When making a turn, be sure to reduce the travel speed and operate the motion control levers carefully.
- To avoid tip-over accidents, operate across slopes, not up and down. Avoid sudden starts and stops on slopes. Slow down and use extra caution when changing direction on a slope. Park the machine on a firm and level surface.
- Watch where you are going at all times. Watch for and avoid obstacles. Be alert at curbs, near trees, and other obstructions and hidden hazards.
- Do not mow near drop-offs, ditches or embankments. The mower could turn over if a wheel is over the edge of a cliff or ditch, or if an edge caves in.
- Do not drive the machine on streets or highways. Watch for traffic when you cross roads or operate near roads.
- Look to the rear before and when backing. Make sure the area immediately behind you is clear of obstructions or holes, and small children. Use extra caution when machine is equipped with grass catcher.
- Keep bystanders, especially children, and animals away from the mowing area.
- Clear the work area of objects which might be picked up and thrown by the blades.
- Do not direct the opening of the discharge deflector at bystanders or animals. Ejected objects may cause injury. Plan your mowing carefully before starting operation.

### DANGER

To avoid serious injury or death:



- Be sure to disengage the PTO and sit on the operator's seat before starting the engine.

## OPERATING THE FOLDABLE ROPS

### WARNING

To avoid serious injury or death:

- When raising or folding the ROPS, apply parking brake, stop the engine and remove the key.
  - Always perform function from a stable position to the rear of the machine.
  - Fold the ROPS down only when absolutely necessary and raise it and lock it again as soon as possible.
  - Before proceeding to fold the ROPS, check for any possible interference with installed implements and attachments.
- If interference occurs, contact your KUBOTA Dealer.

### 1. Folding the ROPS

1. Loosen the knob bolts 1 to 2 turns.
2. Remove both lock pins.

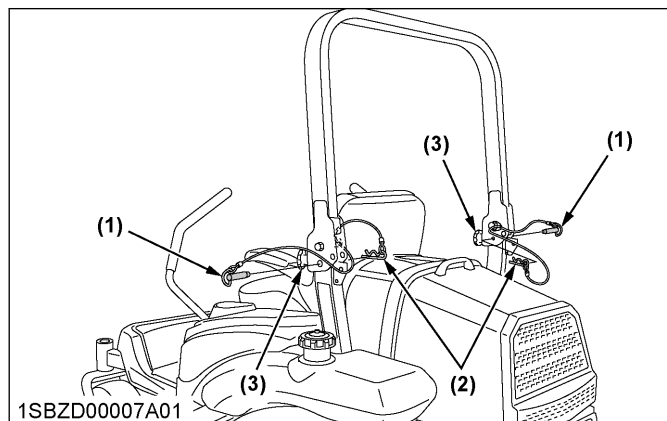

- (1) Lock pin
- (2) Snap pin
- (3) Knob bolt

3. Fold the ROPS.

### CAUTION

To avoid personal injury:

- Hold the ROPS tightly with both hands and fold the ROPS slowly and carefully.

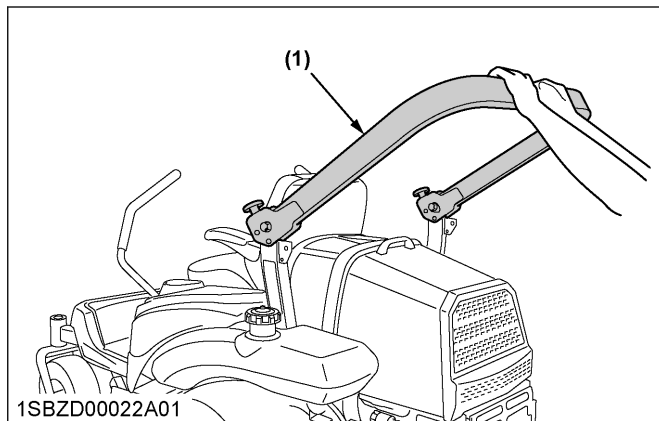

- (1) ROPS

4. Align the lock pin holes and insert both lock pins and secure them with the snap pins.

### WARNING

To avoid serious injury or death:

- Make sure that both lock pins are properly installed and secured with the snap pins.
- Do not use your fingers to align the holes.

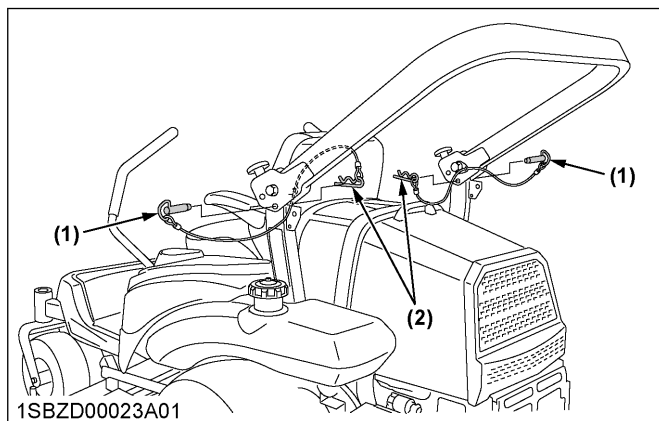

- (1) Lock pin
- (2) Snap pin

## 2. Raising the ROPS to the upright position

1. Remove both snap pins and lock pins.

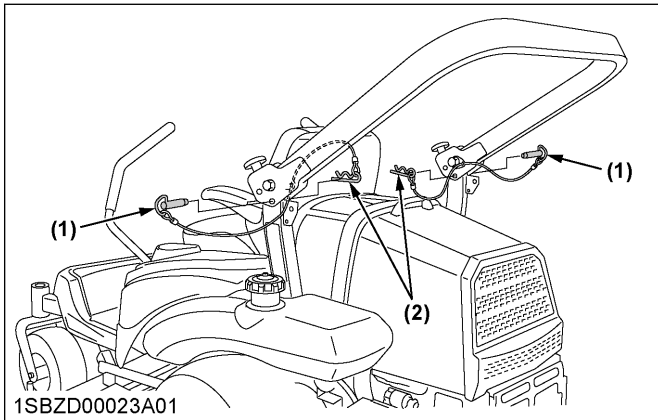

- (1) Lock pin  
(2) Snap pin

2. Raise the ROPS to the upright position.

### **! WARNING**

To avoid serious injury or death:

- Hold the ROPS tightly with both hands and raise the ROPS slowly and carefully.
- Do not use your fingers to align the holes.

3. Align the lock pin holes, insert both lock pins and secure them with the snap pins.
4. Tighten the knob bolts slightly.

### **! CAUTION**

To avoid personal injury:

- Make sure that both lock pins are properly installed as soon as the ROPS is in the upright position and secured with the snap pins.

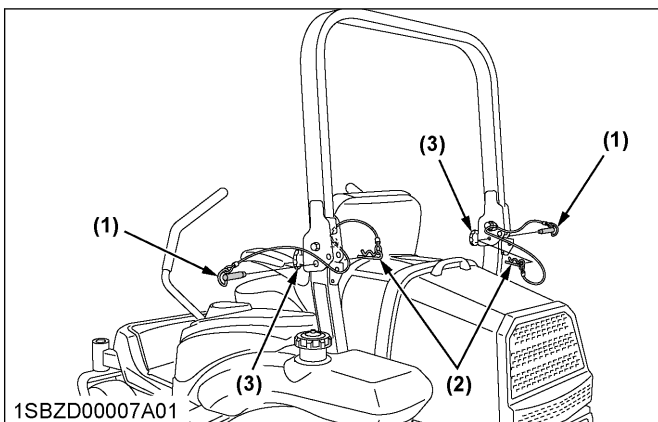

- (1) Lock pin  
(2) Snap pin  
(3) Knob bolt

## 3. Adjusting the foldable ROPS

1. Adjust the free fall of the ROPS upper frame regularly.
2. If you feel less friction when folding the ROPS, tighten the nut (1) until you feel the right friction when moving it. Then replace the snap pin.

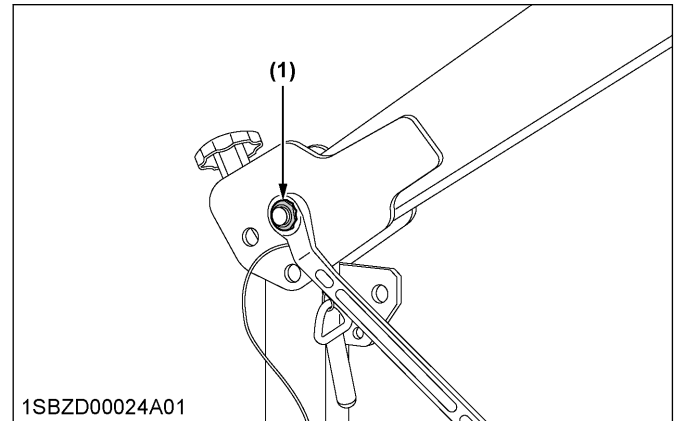

- (1) Nut

## STARTING THE MACHINE

1. Adjust the operator's position and apply the seat belt.
  - Operator's seat on page 31
  - Seat belt on page 32
2. Raise the implement.
  - Hydraulic lift control pedal on page 32
3. Accelerate the engine.
  - Throttle lever on page 33
4. Unlock the parking brake.
  - Parking brake pedal on page 33
5. Operate the machine.
  - Motion control lever on page 33
  - Stop position of the motion control lever on page 33
  - Operating position of the motion control lever on page 34
  - Re-start on slopes on page 35

### 1. Operator's seat

#### **! WARNING**

To avoid serious injury or death:

- Make adjustments to the seat only while the machine is stopped.
- Make sure that the seat is completely secured after each adjustment.
- Do not allow anyone other than the driver to ride on the machine.

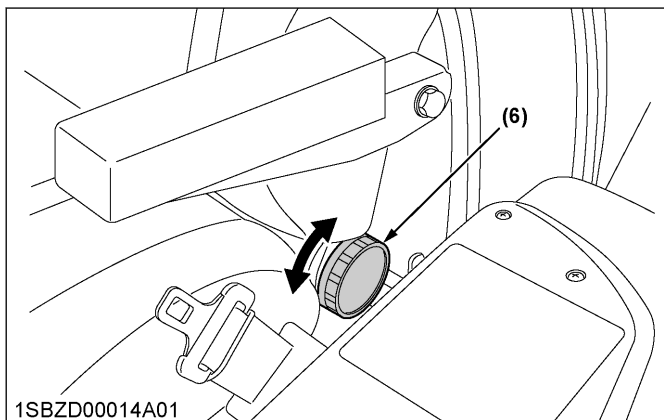
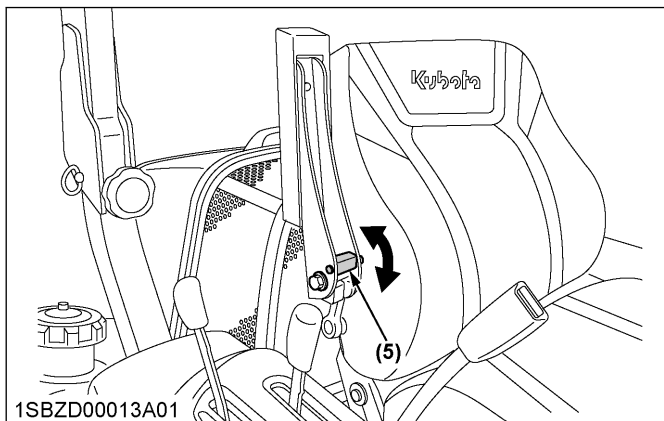
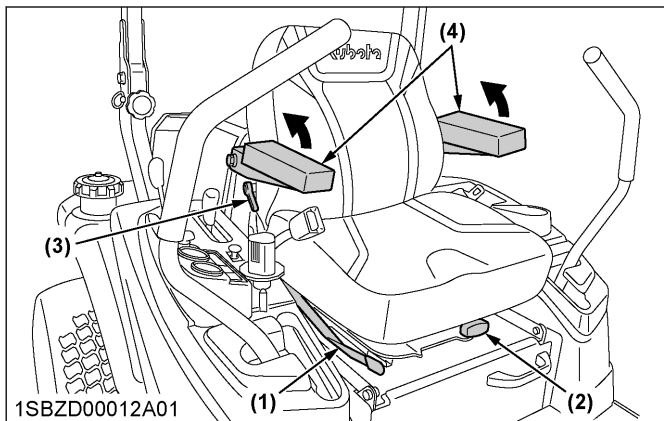

- (1) Travel adjust lever
- (2) Suspension adjust knob
- (3) Lumbar support adjust lever
- (4) Arm rest
- (5) Arm rest angle adjuster
- (6) Backrest tilt adjust knob

**! WARNING**  
 To avoid serious injury or death:  
 • Use extra caution when unlocking the travel adjust lever because the seat might slide forward by itself.

**Travel adjustment**  
 Unlock the travel adjust lever and slide the seat backward or forward, as required. The seat will lock in position when the lever is released.

**Suspension adjustment**  
 Pull the suspension adjust knob and turn it to achieve the optimum suspension setting. After setting, push back the knob.

**Lumbar support adjustment**  
 Turn the lumbar support adjust lever to the desired position.

**Arm rest**  
 Arm rest may be set at upright position if desired.

**Arm rest angle adjustment**  
 Turn the arm rest angle adjuster to the desired angle.

**Backrest tilt adjustment**  
 Turn the backrest tilt adjust knob to the desired angle.

**IMPORTANT :**  
 • After adjusting the operator's seat, be sure to check to see that the seat is properly locked.

**2. Seat belt**

**! WARNING**  
 To avoid serious injury or death:  
 • Always use the seat belt when the ROPS is installed.  
 • Do not use the seat belt if a foldable ROPS is down or if there is no ROPS.

Adjust the seat belt for proper fit and connect to the buckle. The seat belt is an auto-locking retractable type.

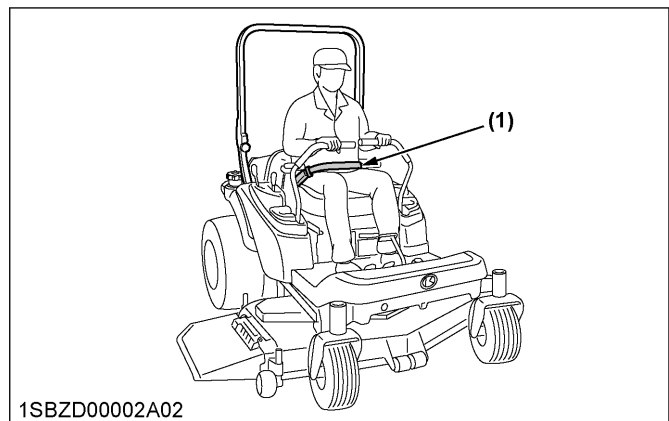

(1) Seat belt

**3. Hydraulic lift control pedal**

The hydraulic lift control pedal is used to raise and lower the implement used with the machine (mower).  
 To lower the implement, depress the hydraulic lift control pedal (DOWN).  
 To raise it, depress the hydraulic lift control pedal (UP).

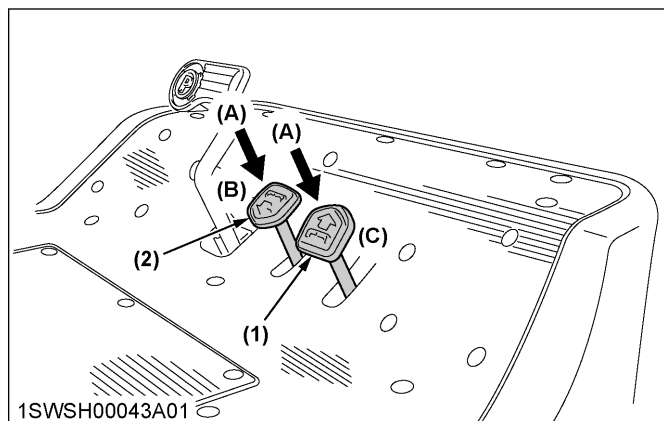

(1) Hydraulic lift control pedal (UP) (A) "DEPRESS"  
 (2) Hydraulic lift control pedal (DOWN) (B) "DOWN"  
 (C) "UP"

**IMPORTANT :**

- Do not operate until the engine is warmed up. If operation is attempted when the engine is still cold, the hydraulic system may be damaged.
- Do not operate at slow engine rpm. Move the throttle lever above 1/2.
- If noises are heard when implement is lifting after the hydraulic lift control pedal has been activated, the hydraulic mechanism is not adjusted properly. Contact your local KUBOTA Dealer for adjustment.
- Do not depress the hydraulic lift control pedal. When the engine is off, depressing the hydraulic lift control pedal (UP or DOWN) will lower the implement.

**4. Throttle lever**

- Move the throttle lever backward to decrease the engine speed.
- Move it forward to increase the engine speed.

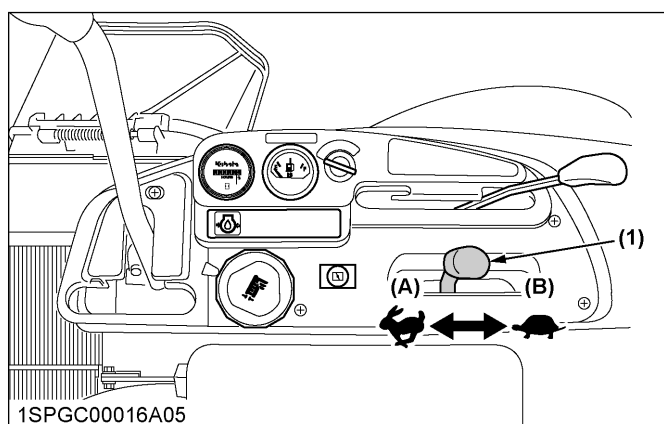

(1) Throttle lever (A) "INCREASE"  
 (B) "DECREASE"

**5. Parking brake pedal**

**To release the parking brake:**

Depress the parking brake pedal and release it slowly with your right foot, without pressing the parking brake lock pedal.

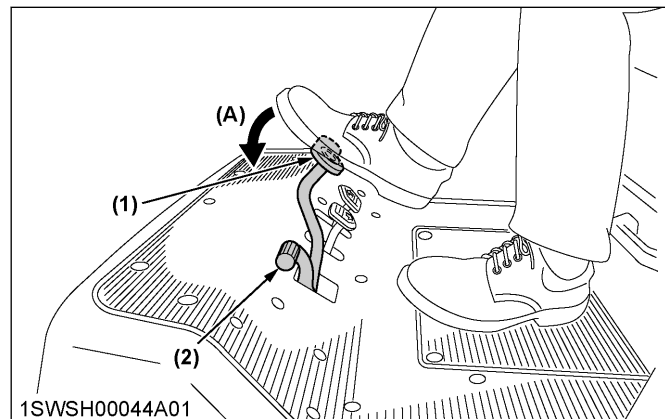

(1) Parking brake pedal (A) "DEPRESS"  
 (2) Parking brake lock pedal

**6. Motion control lever**

**! WARNING**

To avoid serious injury or death:

- Understand how to use the motion control levers and practice in an unrestricted area at slightly more than idle speed without the mower engaged until becoming proficient in the operation of the machine.
- Do not move motion control levers from the "FORWARD" to "REARWARD" or from the "REARWARD" to "FORWARD" position rapidly. Sudden direction changes could cause the loss of control or damage to the machine or property.
- Do not make sharp turns at high speed. Fast and sharp turns could cause the loss of control.
- Motion control levers must be in the "NEUTRAL LOCK" position to safely enter and exit the operator's seat or to carry out maintenance and safety checks.
- This machine can make sharp turns. Always make sure your intended path is clear of obstructions or people.

**6.1 Stop position of the motion control lever**

**Neutral lock position**

Forward and rearward movements of the motion control levers are locked when these levers are in the "NEUTRAL LOCK" position (the engine can only be started with levers in this position).

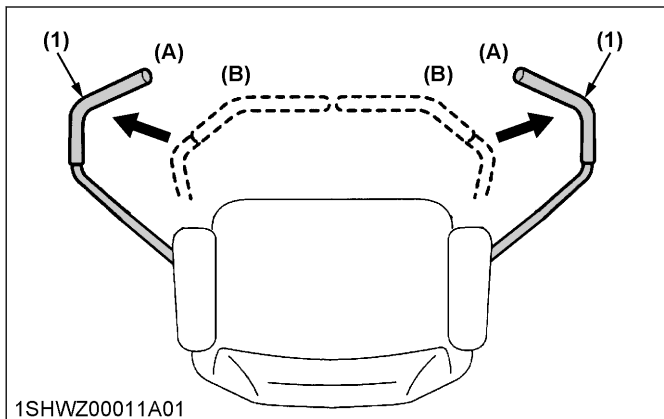

1SHWZ00011A01  
 (1) Motion control levers (A) "NEUTRAL LOCK" position  
 (B) "NEUTRAL" position

**6.2 Operating position of the motion control lever**

Machine speed and steering is controlled by the motion control levers, when the engine is running and the parking brake is released.

**! WARNING**  
**To avoid serious injury or death:**

- No control is provided by the motion control levers when the engine is off.

**Neutral position**  
 Grasp the motion control levers and move them inward from the "NEUTRAL LOCK" position so that the machine is in "NEUTRAL" (the engine cannot be restarted).

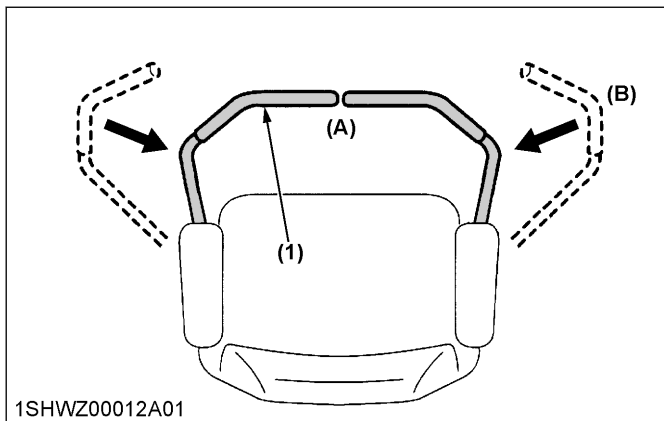

1SHWZ00012A01  
 (1) Motion control levers (A) "NEUTRAL" position  
 (B) "NEUTRAL LOCK" position

- Forward and rearward motion:**
1. Move the throttle lever to the "FAST" position.
  2. Release the parking brake.
  3. Move both motion control levers from the "NEUTRAL LOCK" position inward to the "NEUTRAL" position.
  4. To move your machine, see the following figures.

**To move reverse:**  
 Pull both control levers slowly rearward at the same time to begin reverse motion.

**To stop:**  
 Move and hold both motion control levers to the "NEUTRAL" position until the machine comes to a stop.

**Forward:**  
 For forward travel in a straight line, push both motion control levers slowly and forward equally at the same time.

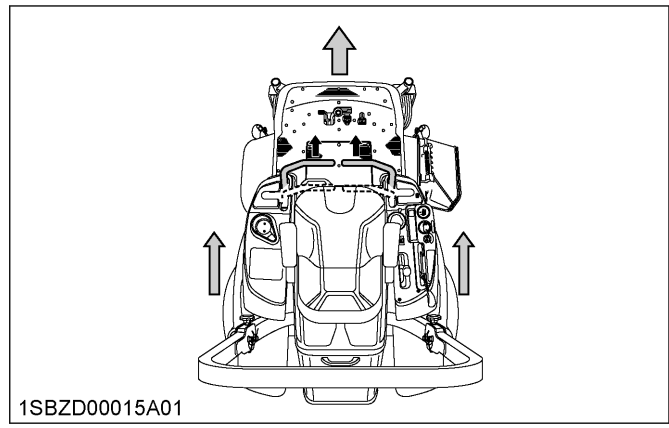

1SBZD00015A01

**Rearward:**  
 For rearward travel in a straight line, pull both motion control levers past center rearward slowly and equally at the same time.

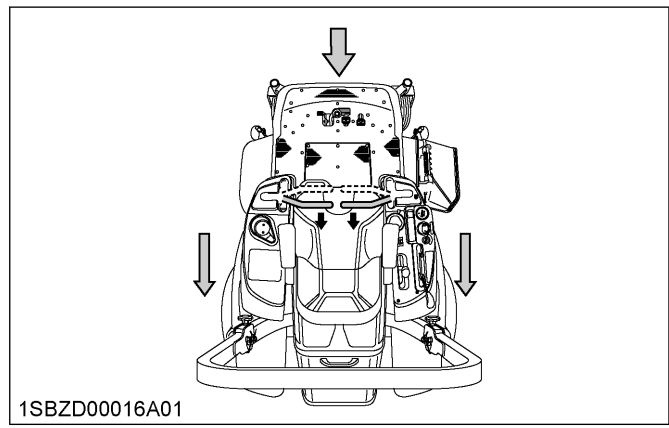

1SBZD00016A01

**General left turn:**  
 For forward travel to the left, push the right motion control lever further forward than the left motion control lever.

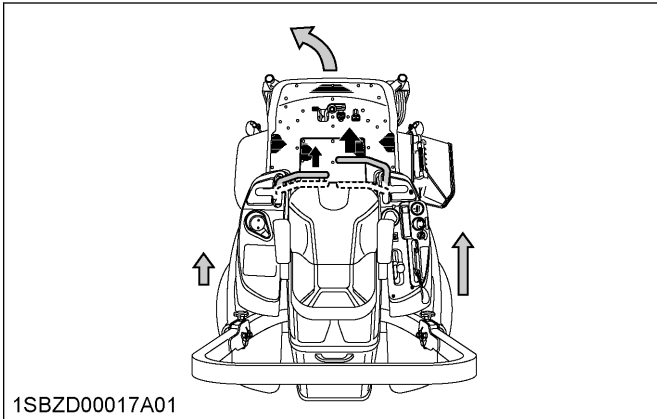

**General right turn:**

For forward travel to the right, push the left motion control lever further forward than the right motion control lever.

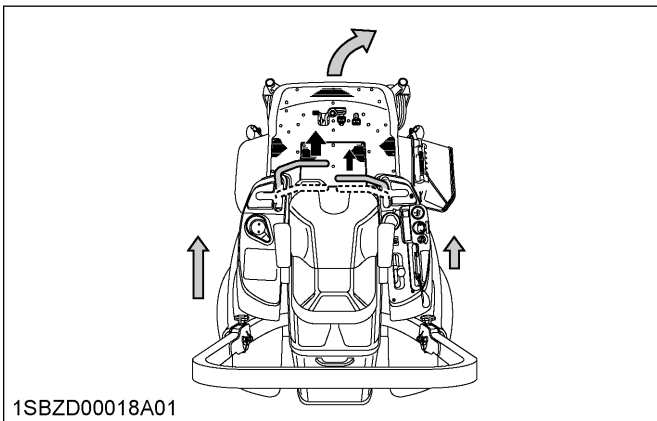

**Sharp (zero) left turn:**

Push the right motion control lever forward and pull the left motion control lever rearward at the same time.

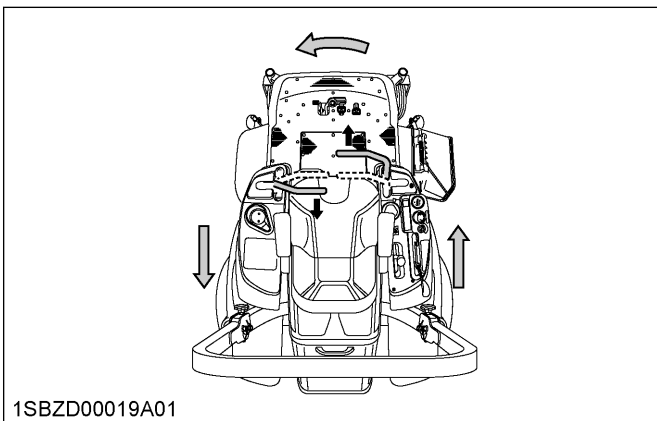

**Sharp (zero) right turn:**

Push the left motion control lever forward and pull the right motion control lever rearward at the same time.

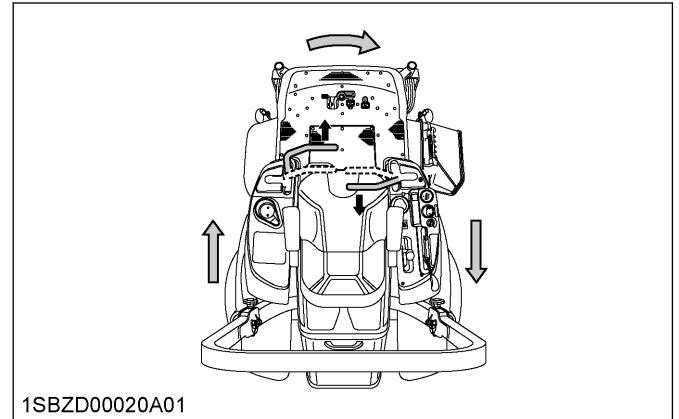

**Adjustment**

**! WARNING**

To avoid serious injury or death:

- The motion control lever adjustment is important to ensure the machine operates properly.

**NOTE :**

- The motion control linkages are adjustable. (If adjustment is required, see ADJUSTMENT on page 78.) We recommend you to contact your local KUBOTA Dealer.

**6.3 Re-start on slopes**

**! WARNING**

To avoid serious injury or death:

- Do not stop or change directions on slopes. These operations could cause loss of the machine traction or control.
- Starting procedure on slopes is different from the usual start mode on a flat surface, understand how to re-start on slopes and use extra caution.

If a situation occurs where it is necessary to stop and restart on a slope, refer to the following operational steps.

**How to re-start on the slopes:**

1. Firmly apply parking brake (enough to prevent movement).
2. Start the engine.
3. Set the throttle lever to the middle position.
4. Place the control levers inward to the "NEUTRAL" position gradually.

5. Release the parking brake within about 3 seconds. If you take more time, the engine will suddenly stop because of a safety device. (This is to prevent the machine from being operated with the parking brake applied.)  
When the engine stops, start over by firmly reapplying the parking brake, and repeat steps 2 through 5 and then 6.
6. Move the machine slowly and carefully.

## STOPPING THE MACHINE

### WARNING

To avoid serious injury or death:

- Park the machine on level ground.  
If necessary to park on an incline, stop the machine, apply the parking brake, and then stop the engine.
- If you stop the engine on an incline without applying the parking brake, the machine could move and run away.

### IMPORTANT :

- The parking brake pedal is for parking and emergency use only. If the parking brake is applied when the motion control levers are not in the “NEUTRAL LOCK” position, the engine will stop within approximately 3 seconds. This feature is to prevent brake and transmission damage during operation.
  - If on a slope and the engine quits, use the parking brake as the emergency brake and immediately stop the unit.
1. Move both motion control levers to the “NEUTRAL” position to stop the machine.
  2. Apply the parking brake.
  3. Move both motion control levers to the “NEUTRAL LOCK” position.
  4. Move the throttle lever to the half speed position and shift PTO lever to the “DISENGAGE” (OFF) position.
  5. Lower all implements to the ground.
  6. Turn off the engine and remove the key.

### IMPORTANT :

- Do not stop the engine when the machine is on an incline for a long time. The engine oil may go into the carburetor and the muffler through the valve system.
- Place the throttle control lever in the half speed position to help prevent the engine from backfiring before stopping the engine.

## PARKING THE MACHINE

### WARNING

To avoid serious injury or death:

Before leaving the operator's position:

- Apply the parking brake.
- Lower all implements to the ground.
- Shut off the engine.
- Remove the key.
- Place the motion control levers in the “NEUTRAL LOCK” position.

To lock:

1. Depress the parking brake pedal firmly with your right foot, and the parking brake lock pedal simultaneously with your left foot.
2. Then release the parking brake pedal while holding the parking brake lock pedal down.

To unlock:

Depress the parking brake pedal and release it slowly with your right foot without pressing the parking brake lock pedal.

If necessary to park on an incline, be sure to chock the wheels on the downhill side to prevent accidental rolling of the machine.

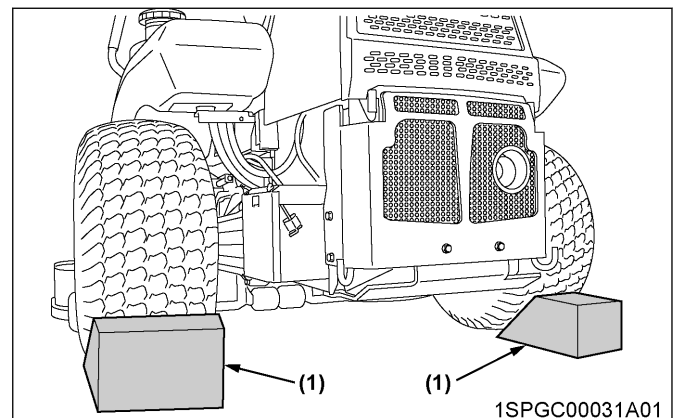

(1) Chock

## TRANSPORTING THE MACHINE

1. Transport the machine on a suitable trailer.
  - Turn the carburetor fuel valve to the “OFF” position.
  - Fasten the machine to the trailer.
  - To prevent the hood from opening by wind while in transit, it is necessary to either load the machine backward or use a suitable tie down for the hood.
  - For a long distance transit, lower the mower deck to the lowest position.
2. Do not attempt to tow this machine, or damage to the transmission may result.
3. When driving the machine over a long distance:

- Turn the cutting height control dial to 5 in. position.
- Lower the mower deck by depressing the hydraulic lift control pedal (DOWN).

## WORK LIGHT (OPTIONAL KIT)

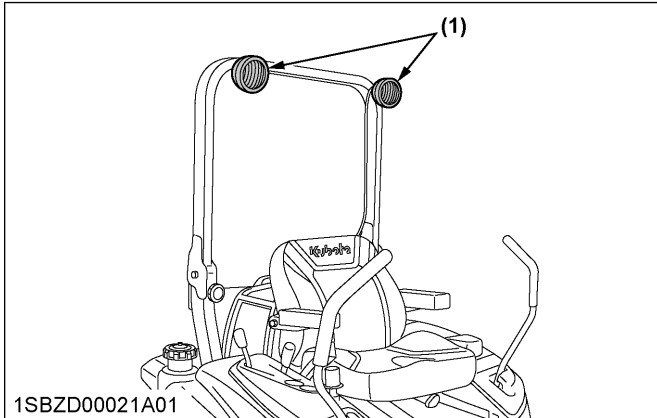

(1) *Work light*



# OPERATING THE MOWER

## MOWING TIPS

1. When using the mower for the first time, choose a smooth level area and cut in straight and slightly overlapping strips.

2. The size and type of the area to be mowed will determine the proper mowing pattern. Take into account obstructions, such as trees, fences and buildings.

To keep grass clippings off fences, sidewalks and so on, it is advisable to go over the outside of the area to be mowed several times in a clockwise direction.

To mow the area remaining, work in a counterclockwise direction so that the clippings are dispersed onto the previously cut area.

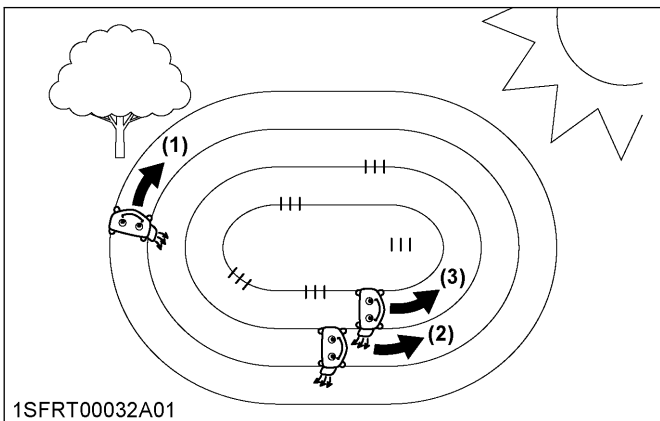

3. Always keep the left side of the mower toward trees, posts or other obstacles on the first trip around the obstacle.

4. Most lawns must be mowed to keep the grass approximately 50 to 80 mm (2 to 3 in.) high. Best results are obtained by cutting often and not too short.

For a healthy lawn, only 1/3 of the grass plant should be removed in one mowing. For example, tall grass with the height of 75 mm (3 in.) can be cut to a minimum of 50 mm (2 in.).

For extremely tall grass, set the cutting height at maximum cutting height for the first mowing, then reset to the desired height and mow again. Allow the grass to grow to 80 mm (3 in.), then cut off only the top 25 mm (1 in.).

5. Clippings may be left on the lawn unless they form clumps or rows.

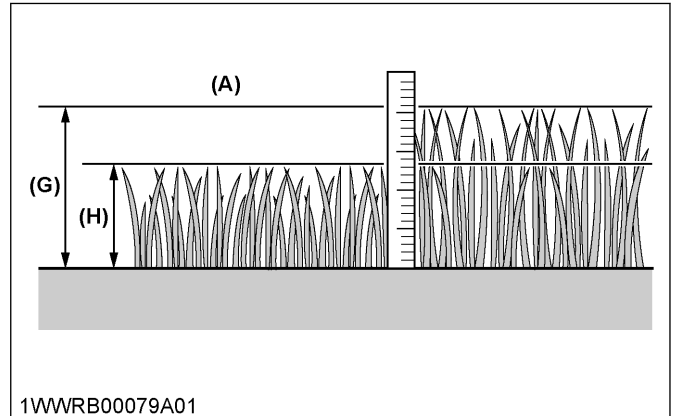

- (A)  $H/G > 2/3$
- (G) Before mowing
- (H) Best cut grass height: 50 to 80 mm

6. For best appearance, grass must be cut in the afternoon or evening when it is free of moisture.

## ADJUSTING THE CUTTING HEIGHT

### DANGER

To avoid serious injury or death:

- Do not engage the mower in the transport position.

Cutting height control dial can adjust the cutting height from 25 mm (1 in.) to 127 mm (5 in.) with 6 mm (0.25 in.) step.

1. Before adjusting the cutting height, check that all tire pressures are correct. If necessary, adjust to the correct tire pressure.

- To set the cutting height, start engine and depress the hydraulic lift control pedal (UP) to raise mower deck to the top position. Adjust the cutting height control dial to desired height.  
Lower the mower deck by depressing the hydraulic lift control pedal (DOWN).  
Then the mower deck will be set to the cutting height.

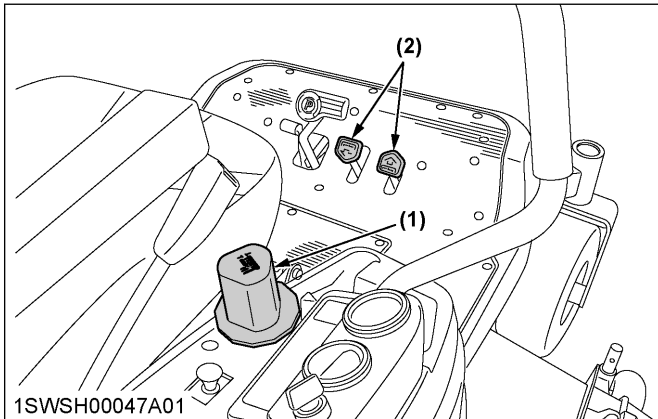

- Cutting height control dial
- Hydraulic lift control pedal

- Use the higher settings for mowing in a rough area or when mowing tall grass. Lower settings must be used only for smooth lawns where short grass is desired.
- Lower the mower deck by depressing the hydraulic lift control pedal (DOWN). This lowers the mower deck from the "TRANSPORT" position to the "OPERATING" position.
- Adjust the anti-scalp rollers' height as recommended below for normal operating condition. To minimize gouging and roller damage or wear, the anti-scalp rollers will maintain the ground clearance of 19 mm (0.75 in.).

**IMPORTANT :**

- Never allow the rollers to contact the ground continuously as premature roller wear may develop if set incorrectly.
- Anti-scalp rollers must maintain a minimum clearance of 6 mm (0.25 in.) to the ground.

**[PIN]**

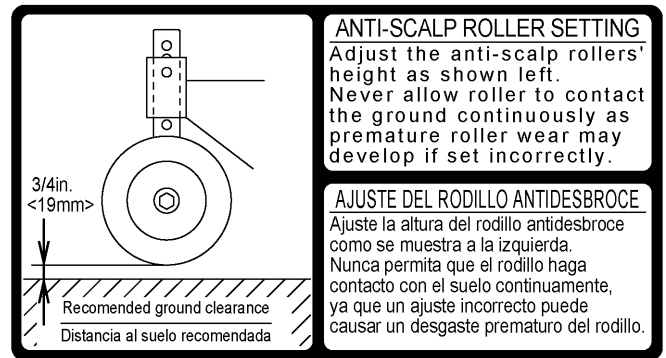

1SWSH00048A01enUS

**RCK60P**

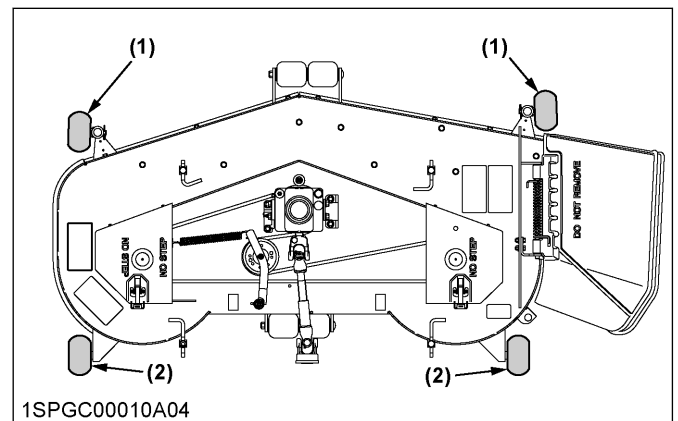

- Anti-scalp roller (front, pin shift type)
- Anti-scalp roller (rear, bolt shift type)

### 1. Cutting height reference chart

- Set position for recommended ground clearance 19 mm (0.75 in.).

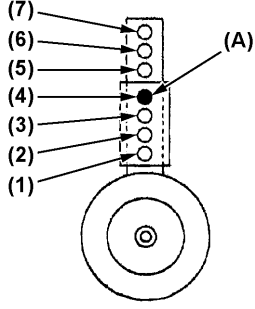
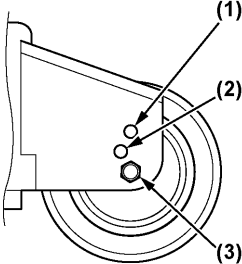
Cutting height inch (mm)	Position of pins 	Position of bolts 	Ground clearance mm (Ref.)	
			Rear anti-scalp roller	
			Pin shift type	Bolt shift type
1.00" (25)	1	1	6	6
1.25" (32)	2		13	12
1.50" (38)	1		19	19
1.75" (44)	3	2	13	25
2.00" (50)	2		19	19
2.25" (58)	4		13	25
2.50" (64)	3	3	19	19
2.75" (70)	5		13	25
3.00" (76)	4		19	(31) <sup>*1</sup>
3.25" (83)	6		13	(38) <sup>*2</sup>
3.50" (89)	5		19 <sup>*3</sup>	(44) <sup>*2</sup>
3.75" (95)	7		13 <sup>*2</sup>	(51) <sup>*2</sup>
4.00" (102)	6		19 <sup>*2</sup>	(57) <sup>*2</sup>
4.25" (108)	7		13 <sup>*2</sup>	(63) <sup>*2</sup>
4.50" (114)	7		19 <sup>*2</sup>	(70) <sup>*2</sup>
4.75" (121)	7		25 <sup>*2</sup>	(76) <sup>*2</sup>
5.00" (127)	7	31 <sup>*2</sup>	(83) <sup>*2</sup>	

\*1 For cutting heights above 3.0". The anti-scalp rollers will still be effective against scalping.

\*2 Use it if necessary.

\*3 For cutting heights above 3.5". The anti-scalp rollers will still be effective against scalping.

## OPERATING THE MOWER

### **!** DANGER

To avoid serious injury or death:

- Do not operate the mower without the discharge deflector being in place properly.

### **!** WARNING

To avoid serious injury or death:

- Clear the work area of objects which might be picked up and thrown.
- Do not direct the opening of the discharge deflector at bystanders, especially children, or animals. Discharged objects may cause injury. Plan your mowing carefully before starting the operation.
- Keep bystanders and animals away from the mowing area.
- Be sure to disengage the PTO clutch of the mower before attempting to start the engine.

## 1. PTO lever

To engage the PTO, move the PTO lever to the "ENGAGED" (ON) position.

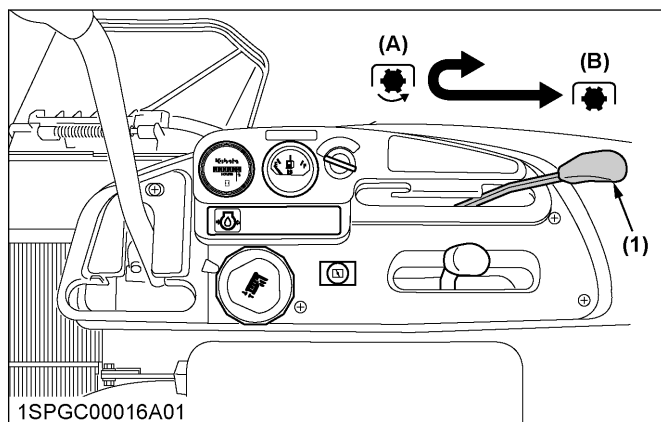

(1) PTO lever

(A) "ENGAGED" (ON)

(B) "DISENGAGED" (OFF)

1. If you get off the seat while the PTO is running, the engine will stop automatically. (Operator presence control)
2. Before starting the engine, pull the PTO lever to the "DISENGAGED" (OFF) position. If it is at the "ENGAGED" (ON) position, the engine will not start.

#### NOTE :

- These safety features are built-in.

## 2. Starting the machine

### **!** WARNING

To avoid serious injury or death:

- Engine components can get extremely hot from operation. To prevent severe burns, do not touch these areas while the engine is running, or immediately after it is turned off.
- Never operate the engine without heat shields or guards.

1. Sit on the operator's seat. Put on the seat belt. Make sure that the parking brake is engaged.
2. Start the engine.
3. Engage the PTO lever.
4. Disengage the parking brake.
5. Speed up the engine by moving the throttle lever forward.
6. Push or pull the motion control levers to move forward or rearward.

#### IMPORTANT :

- Never attempt to move the machine with the parking brake "ON".

#### NOTE :

- Keep the engine running at full throttle for best results. Control the travel speed with the motion control levers.
- During heavy duty use, operate the machine at a slower ground speed or go over the area twice.
- Keep the mower deck in the raised position when the mower is disengaged.
- The mower will not cut cleanly if the ground speed is too high or if the blade speed drops due to an overload.
- If debris builds up on the grass screen or other cooling air intake areas, stop the engine and clean them. Operating the engine with blocked or dirty air intake and cooling areas causes damage due to overheating.

# TIRES AND WHEELS

## TIRES

**⚠ WARNING**

To avoid serious injury or death:

- Do not attempt to mount a tire. This should be done by a qualified person with the proper equipment.
- Always maintain the correct tire pressure. Do not inflate tires above the recommended pressure shown in the operator's manual.
- The inflation pressure in the front tires rises quickly when using compressed air.
- Never operate the machine with a loose rim, wheel, or axle.
- Whenever bolts are loosened, retighten to the specified torque.
- Check all the bolts frequently and keep them tightened.

### 1. Inflation pressure

Even though the inflation pressure is factory-set to the prescribed level, it naturally drops slowly in the course of time. Therefore, check it everyday and inflate as necessary.

	Tire sizes	Recommended inflation pressure
Front	15 × 6.0 - 6, (non flat tire) rib	—
Rear	26 × 12.0 - 12, 4PR turf	120 kPa (1.2 kgf/cm <sup>2</sup> , 17 psi)

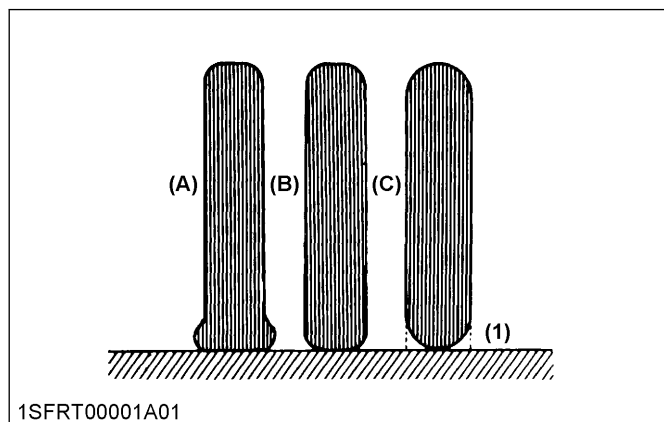

(1) Ground  
(A) "INSUFFICIENT" (B) "NORMAL" (C) "EXCESSIVE"

## WHEELS

### IMPORTANT :

- When refitting a wheel, tighten the wheel bolts and nuts to the following torques then recheck after traveling 200 m (200 yards), changing directions several times.

### Rear

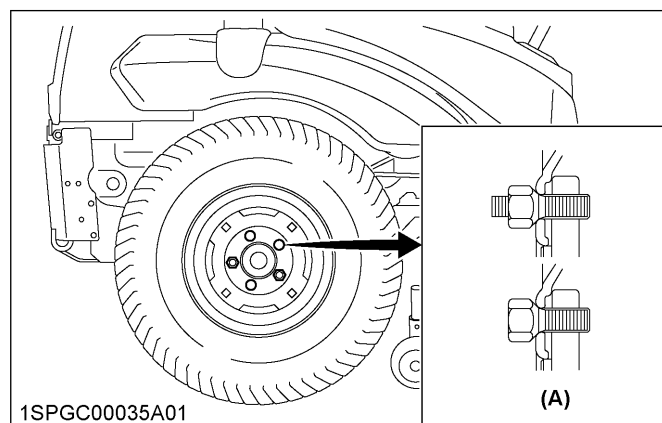

(A) 108.5 to 130.2 N · m  
(80 to 96 lbf · ft)  
(11.1 to 13.3 kgf · m)

When using wheels with beveled or tapered holes, use tapered wheel bolts and tapered nut.

### 1. Removing the front caster wheels

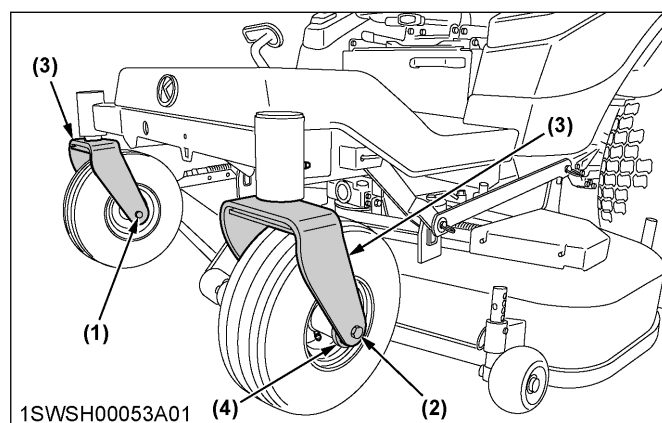

(1) Lock nut  
(2) Wheel bolt  
(3) Yoke  
(4) Dust cover

1. Park the machine on a firm and level surface.
2. Stop the engine and apply parking brake.
3. Lift the front of machine with a safe lifting device.

4. Remove the lock nut nylon sleeve and the wheel bolt.
5. Remove the wheel and dust cover from assembly yoke.

## 2. Installing the front caster wheels

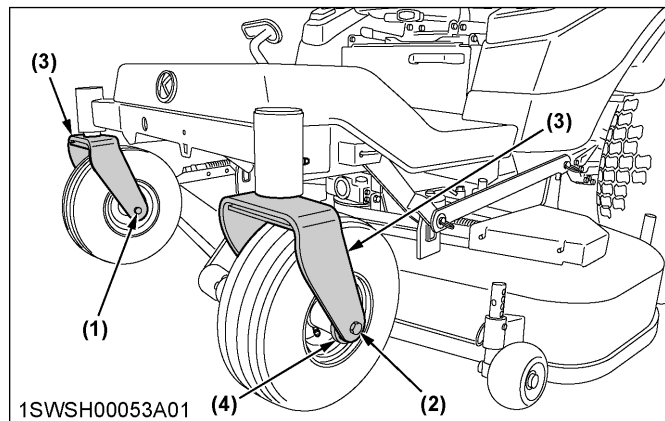

- (1) Lock nut  
 (2) Wheel bolt  
 (3) Yoke  
 (4) Dust cover

1. Install the replacement wheel and dust cover.
2. Install the wheel bolt and the lock nut with nylon sleeve.
3. Tighten the nut.
4. After installing, grease to the grease fittings.

### IMPORTANT :

- Insert the wheel bolt from the outside of the yoke.
- Tighten the nut gradually until the wheel bearing play is eliminated and the wheel turns freely by hand.

Tightening torque	20 to 25 N · m (14.8 to 18.4 lbf · ft) (2 to 2.5 kgf · m)
-------------------	---

5. Lower the machine.

# MAINTENANCE

## SERVICE INTERVALS

The following servicing tasks should be carried out on the machine at the stated running-time intervals.

No.	Items		Indication hour meter (Hr)												Ref. page			
			50	100	150	200	250	300	350	400	450	500	550	600			After since	
1	Engine oil	Change	⊙		○		○		○		○		○		○	every 100Hr	60	*1
2	Engine oil filter	Replace	⊙				○						○			every 200Hr	69	*1
3	HST transmission oil filter	Replace	⊙			○				○				○		every 200Hr	70	*1
4	Mower gear box oil	Check	○	○	○	○	○	○	○	○	○	○	○	○	○	every 50Hr	57	
		Change			○			○			○			○		every 150Hr	68	
5	Engine start system	Check	○	○	○	○	○	○	○	○	○	○	○	○	○	every 50Hr	56	
6	OPC system	Check	○	○	○	○	○	○	○	○	○	○	○	○	○	every 50Hr	57	
7	Greasing (except mower)	—	○	○	○	○	○	○	○	○	○	○	○	○	○	every 50Hr	58	
8	Oiling	—	○	○	○	○	○	○	○	○	○	○	○	○	○	every 50Hr	59	
9	Air cleaner primary element	Clean		○		○		○		○		○		○		every 100Hr	60	*2
		Replace														every 1000Hr or 1 year	73	*3
	Secondary element	Replace														every 1000Hr or 1 year	73	*3
10	Fuel filter element	Check		○		○		○		○		○		○		every 100Hr	63	
		Replace								○						every 400Hr	73	*4
11	Parking brake	Adjust		○		○		○		○		○		○		every 100Hr	65	*5
12	Battery condition	Check		○		○		○		○		○		○		every 100Hr	66	*6
13	Engine shroud panel	Clean		○		○		○		○		○		○		every 100Hr	61	*5
14	Engine oil cooler fins	Clean		○		○		○		○		○		○		every 100Hr	62	*7 *5
15	Fuel filter bowl	Clean		○		○		○		○		○		○		every 100Hr	64	
16	Throttle cable	Adjust		○		○		○		○		○		○		every 100Hr	68	
17	Spark plug condition and gap	Check				○				○				○		every 200Hr	70	
18	Motion control lever pivot	Adjust				○				○				○		every 200Hr	71	
19	Engine shroud	Clean				○				○				○		every 200Hr	71	*4
20	Hydraulic oil filter	Replace								⊙						every 400Hr	72	
21	Transmission fluid and rear axle gear case (RH and LH) fluid	Change								⊙						every 400Hr	71	
22	Engine valve clearance	Adjust												○		every 500Hr	73	
23	Combustion chamber	Clean														After 1000Hr	73	*8
24	Fuel line	Check														every 1 year	63	*9 *5
		Replace														every 4 years	75	*4
25	Hydraulic hose	Check														every 1 year	73	*9 *5
		Replace														every 4 years	75	*4

(Continued)

No.	Items	Indication hour meter (Hr)													Ref. page		
		50	100	150	200	250	300	350	400	450	500	550	600	After since			
26	Intake air line	Check													every 1 year	74	*9 *5
		Replace													every 4 years	75	*5
27	Engine breather hose	Check													every 1 year	74	*9 *4
		Replace													every 4 years	75	*4
28	Mower gear box oil seal	Check													every 1 year	74	*9 *4
		Replace													every 4 years	75	*4
29	One way valve	Replace													every 2 years	75	*4
30	Fuse	Replace													Service as re- quired	75	
31	Blade	Replace												76			
32	Mower belt	Replace												77			
33	Fuel system	Bleed												77			

- \*1 The initial 50 hours should not be a replacement (change) cycle.
- \*2 Air cleaner must be cleaned more often in dusty conditions than in normal conditions.
- \*3 Every 1000 hours or every 1 year whichever comes faster.
- \*4 Consult your local KUBOTA Dealer for this service.
- \*5 If you feel you are unable to make the following service correctly and safely, contact your local KUBOTA Dealer.
- \*6 When the battery is used for less than 100 hours per year, check the battery condition by reading the indicator annually.
- \*7 This maintenance should be done daily or more often in dusty condition than in normal conditions. Suggested cleaning interval is every 100 hours in normal conditions.
- \*8 After 1000 Hr, clean it if necessary.
- \*9 Replace if any deterioration (crack, hardening, scar, or deformation) or damage occurred.

**IMPORTANT :**

- **The jobs indicated by ☉ must be done initially.**
- **Gasoline engine emission related maintenance instructions:**
  1. **Non-warranty maintenance, repair, or replacement of the emission control devices and systems should be performed by a qualified repair establishment or individual which has the experience and equipment to perform such work. See the Emissions Warranty Statement.**
  2. **To ensure the best quality and reliability, use new KUBOTA Genuine parts or their equivalents for repair and replacement, whenever you have maintenance done.**



# PERIODIC SERVICE CHART LABEL

This label is for your quick reference. The label shows the recommended services from daily to every 4 years, including fluid capacities, tire pressure and so on.

For detail, refer to operator's manual.

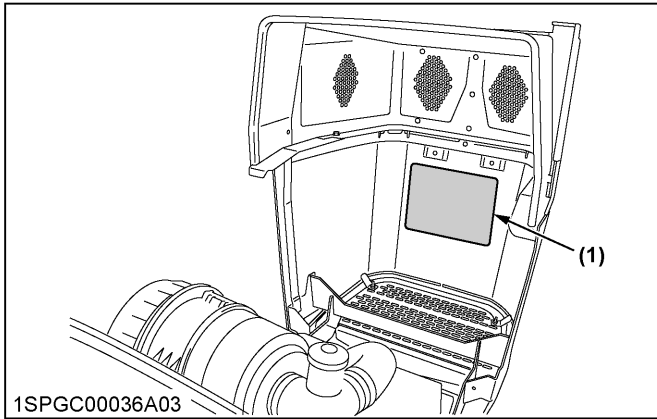

(1) Part No. K3287-6552-4 (ENGLISH)

## PERIODIC SERVICE CHART

INTERVAL		RECOMMENDED SERVICE ※		INTERVAL		RECOMMENDED SERVICE ※	
DAILY	CHECK	1. Tire pressure, wear, or damage. 2. Fuel and oil leakage from machine and mower. 3. Engine and transmission oil and fuel level. 4. Damage to machine body, tightness of all bolts, nuts and pins, etc. 5. Mower blades and belt for wear or damage. 6. Parking brake, speed control levers, all safety switches and easy checker functions. 7. Color of the exhaust fumes, abnormal noise and vibrations.		E	50 Hr.	CHECK	• Mower gear box oil / Engine start system / OPC system
		OIL	• Throttle cable (2 places) / Choke cable (2 places)				
	GREASE	• Front axle and wheel (4 places) / Universal joint (3 places) / Seat adjuster (2 places) / Motion control lever pivot bushing and contact position (2 places each) / Parking brake lock pedal / Front lift arm (2 places)					
	CLEAN	• Bonnet screen, air cleaner primary element, mower deck, bottom dust cover and area around engine.		V	100 Hr.	CHECK	• Fuel filter element (3 places) / Battery condition /
GREASE		• Mower U-joint (3 places) / Spindle shaft (3 places) / Belt tension pulley (1 place) / Belt tension pivot (1 place)				CLEAN	• Engine shroud panels ☆ / Engine oil cooler fins ☆ ☆ / Fuel filter bowl / Air cleaner primary element ★
	FIRST 50 Hr. (BREAK-IN) (MUST BE DONE.)	REPLACE	• Engine & HST Transmission oil filters (2 places)	E	150 Hr.	CHANGE	• Engine oil
CHANGE		• Engine oil	ADJUST			• Throttle cable / Parking brake ☆	
FIRST 400 Hr. (MUST BE DONE.)	REPLACE	• Hydraulic oil filter	R	200 Hr.	CHANGE	• Mower gear box oil	
	CHANGE	• Transmission & Rear axle gear case (RH & LH) fluid			CHECK	• Spark plug condition and gap	
※ : See Operator's Manual in details. ☆ : Should be serviced by KUBOTA Dealer. ★ : Required more often in dusty conditions. ■ : Replace if necessary. ● : Replace for maximum of every 4 years. ▲ : Whichever comes first.	REPLACE	• Fuel filter element (3 places) ☆ / Hydraulic oil filter	Y	400 Hr.	REPLACE	• Engine shroud ☆	
		REPLACE			• Engine oil filter / HST transmission oil filter	ADJUST	• Motion control lever pivot
Approximate fluid capacities.	REPLACE	• Transmission & Rear axle gear case (RH & LH) fluid	Y	500 Hr.	ADJUST	• Valve clearance ※	
		• Air cleaner both elements			CLEAN	• Combustion chamber ※	
Tire pressure and tightening torque recommendation.	REPLACE	• Valve (2 places)	Y	AFTER 1000 Hr.	CHECK	• Hydraulic hose / Fuel line / Mower gear box oil seal / Intake Air Line / Engine breather hose	
		• Valve (2 places)			REPLACE	• Air cleaner both elements	
Engine	ZG327A (KGZ770)	2.0L (2.1qts.)	Front	15x 6.0- 6 (NO FLAT)	NO NEED	Ensure smooth rotation of wheel. <Do not overtighten.>	
Transmission		12.1L (12.8qts.)	Rear	26x12.0-12	120 KPa (17 psi)	108.5-130.2 Nm (80.0-96.0 ft·lbs)	
Mower gear box		0.4L (0.42qts.)					

### Approximate fluid capacities.

### Tire pressure and tightening torque recommendation.

	ZG327A (KGZ770)
Engine	2.0L (2.1qts.)
Transmission	12.1L (12.8qts.)
Mower gear box	0.4L (0.42qts.)

Front	15x 6.0- 6 (NO FLAT)	NO NEED	Ensure smooth rotation of wheel. <Do not overtighten.>
Rear	26x12.0-12	120 KPa (17 psi)	108.5-130.2 Nm (80.0-96.0 ft·lbs)

1SBZD00037A01enUS

## LUBRICANTS AND FUEL

Place	Capacities	Lubricants	
	ZG327PA-AU		
Fuel	48 L (12.7 U.S. gals.)	<ul style="list-style-type: none"> <li>Automobile unleaded or regular gasoline</li> <li>Unleaded gasoline 87 octane or higher</li> </ul>	
Engine crankcase	2.0 L (2.1 U.S.qts.) *1	<ul style="list-style-type: none"> <li>Engine oil: API service Classification SG, SH, SJ or higher Classification <b>SH</b> or higher Above -18 °C (0 °F)...SAE10W-30 or 10W-40 Below 0 °C (32 °F).....SAE5W-20 or 5W-30</li> </ul>	
Transmission case with filter and hose Rear axle gear case (RH and LH)	12.1 L (12.8 U.S.qts.)	<ul style="list-style-type: none"> <li><b>KUBOTA UDT</b> or <b>SUPER UDT</b> fluid *2</li> </ul>	
Mower gear box	0.4 L (0.4 U.S.qts.)	Gasoline engine oil: API service category <b>SH</b> or higher SAE10W-30 *3	
	0.4 L (0.4 U.S.qts.)	Gear oil: API service category: more than GL-3 SAE90 *3	
Greasing	No. of greasing points	Capacity	Type of grease
Front axle	2	Until grease overflows	<ul style="list-style-type: none"> <li>Multipurpose Grease EP2 (NLGI Grade No.2)</li> </ul>
Front wheel	2		
Parking brake lock pedal	1		
Front lift arm	2		
Motion control lever pivot bushing, and contact position	6		
Universal joint	3		
Seat adjuster	2		
Cable (throttle)	2	Moderate amount	<ul style="list-style-type: none"> <li>Oil</li> </ul>
Cable (choke)	2		
(MOWER)		Until grease overflows	<ul style="list-style-type: none"> <li>Multipurpose Grease EP2 (NLGI Grade No.2)</li> </ul>
Universal joint	3		
3 spindle shafts	3		
Belt tension pulley	1		
Belt tension pivot	1		

\*1 Oil amount when the oil level is at the upper level of the oil level gauge.

\*2 KUBOTA original transmission hydraulic fluid

\*3 Check a label on the mower gear box to know which oil you must use in it. (See Checking gear box oil level on page 57 or Changing gear box oil on page 68.)

### IMPORTANT :

- To prevent serious damage to gears, bearings and oil seals, do not mix different kinds of oil.
- To prevent serious damage to hydraulic systems, use only KUBOTA genuine fluid or its equivalent.

### Fuel:

- Gasohol (up to 10% ethyl alcohol, 90% unleaded gasoline by volume) is approved for the engine. Other gasoline/ alcohol blends are not approved.
- Indicated capacity of fuel is manufacture's estimate.

### Engine oil:

- Oil used in the engine should have an American Petroleum Institute (API) service classification and proper SAE Engine oil according to the ambient temperatures as shown above.
- Indicated capacity of oil is manufacture's estimate.

## MAINTENANCE

---

### Transmission oil:

- The oil used to lubricate the transmission is also used as hydraulic fluid. To insure proper operation of the hydraulic system and to complete lubrication of the transmission, it is important that a multi-grade transmission fluid is used in this system. We recommend the use of **KUBOTA UDT** or **SUPER UDT** fluid for optimum protection and performance. (Consult your local KUBOTA Dealer for further detail.)  
Do not mix different brands together.
- Indicated capacity of oil is manufacture's estimate.

# PERIODIC SERVICE

## OPENING THE HOOD, AND STEP

### WARNING

To avoid serious injury or death from contact with moving parts:

- Never open the hood while the engine is running.
- Never open the step while the engine is running.
- Do not touch muffler or exhaust pipes while they are hot; Severe burns could result.

### 1. Hood

1. To open the hood, pull the latch lever frontward and then open.

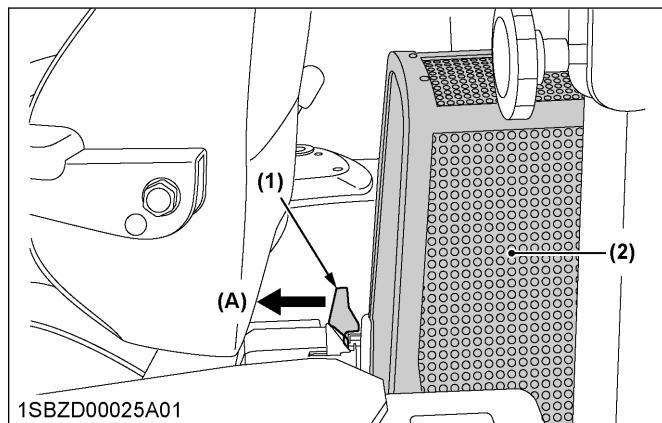

(1) Latch lever  
(2) Hood

(A) "RELEASE"

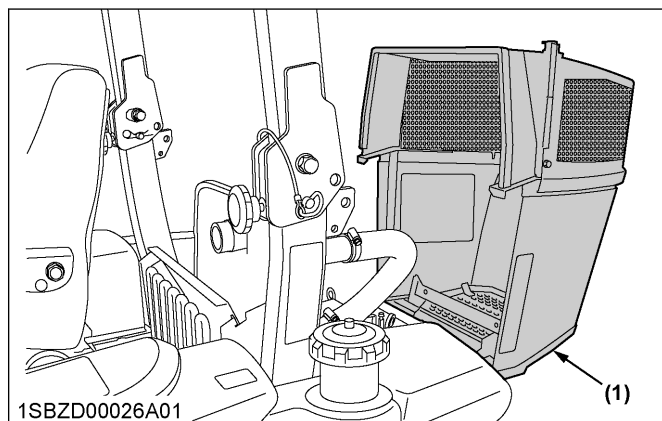

(1) Hood

### 2. Step

1. To open the step, pull the grip.

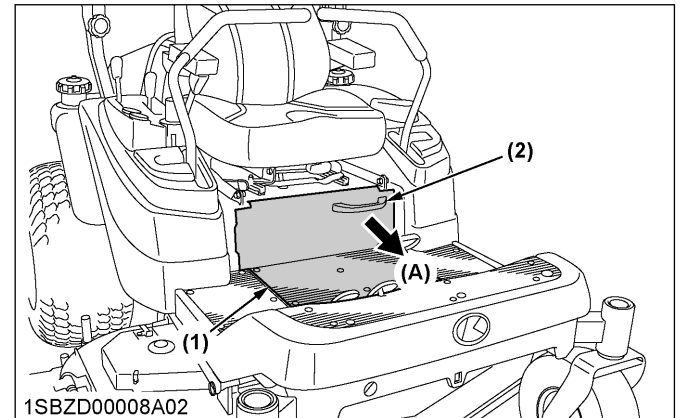

(1) Step  
(2) Grip

(A) "PULL"

## RAISING AND LOWERING THE OPERATOR'S SEAT

### Raising

### WARNING

To avoid serious injury or death:

- Fully raise the operator's seat. (To the locked position)
- Do not keep the seat halfway.

1. Seat must be all the way back before raising.
2. Pull the latch lever on the seat panel frontward.

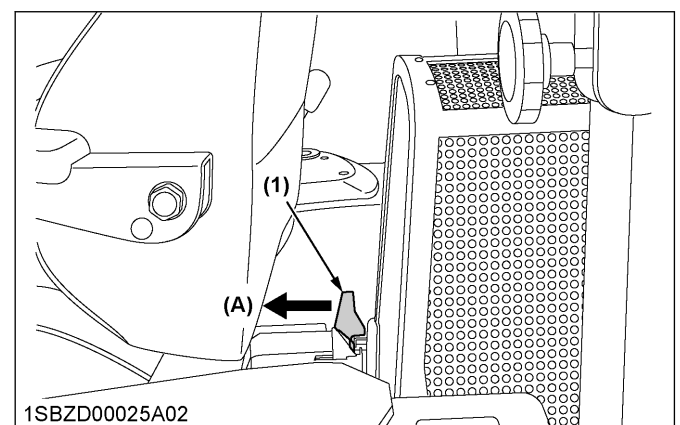

(1) Latch lever

(A) "PULL"

3. Raise the operator's seat to the "LOCK" position.

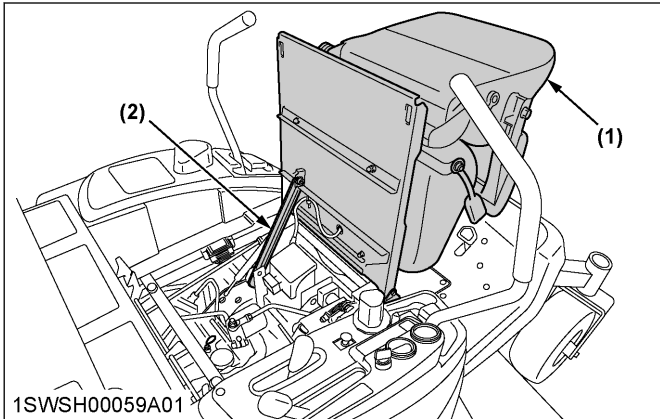

- (1) Operator's seat
- (2) Seat support rod

**Lowering**

**! WARNING**

To avoid serious injury or death:

- Do not drop the seat to close it.
- Watch your hands. Do not place your hands under the seat, when closing.

1. Pull up the seat support rod and release the "LOCK".
2. Lower the seat slowly to lock.
3. Slide the seat to proper position.

**OPENING THE LEVER GUIDE**

**! WARNING**

To avoid serious injury or death:

- Park the machine on a firm and level surface.
- Stop the engine, remove the key and apply the parking brake.

1. Remove the screw of the lever guide.
2. Pull up the lever guide.

**How to install the lever guide.**

1. Install the lever guide.
2. Tighten the screw.

**IMPORTANT :**

- If the lever guide is out of alignment with the motion lever, move the lever guide to align it with the motion control lever.

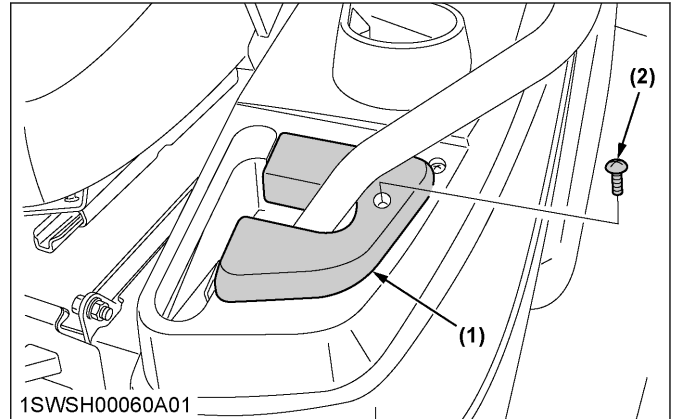

- (1) Lever guide
- (2) Screw

**LIFT-UP POINT**

**! WARNING**

To avoid serious injury, death or machine damage:

- Do not work under the machine unless it is secured by safe stands or suitable blocking.

**IMPORTANT :**

- When you lift the unit, do not lift the bypass pipe between the fuel tanks LH and RH.

**1. Front side:**

1. Hook nylon slings at the front frame. Hoist the front axle support with nylon sling or jack up the front frame. Never lift up the mower deck.

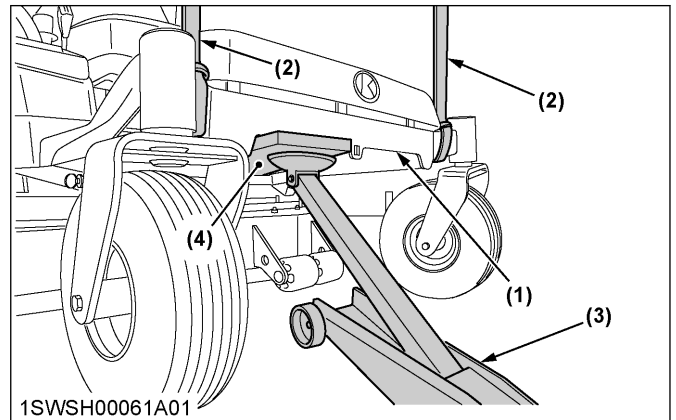

- (1) Front axle frame
- (2) Nylon sling
- (3) Jack
- (4) Wood block

## 2. Rear side:

1. Hoist the rear frame with a nylon sling. Or jack up the bottom plate.  
Never lift up the battery support.

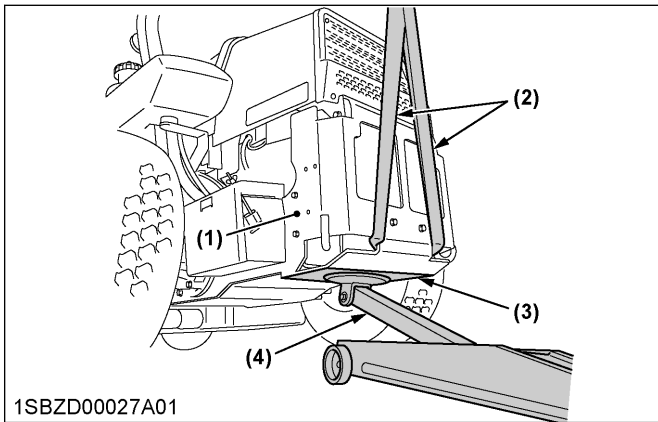

- 1SBZD00027A01
- (1) Rear frame
  - (2) Nylon sling
  - (3) Bottom plate
  - (4) Jack

## DAILY CHECK

To prevent trouble from occurring, it is important to know the condition of the machine. Check it before starting.

### WARNING

To avoid serious injury or death:

- Be sure to check and service the machine on a level surface with the engine shut off, the key removed and the parking brake securely set or the rear wheels chocked.

	No.	Check item	Ref. page
Walking around the machine	1	Damage of machine body, tightness of all bolts and nuts and pins, and so on	—
	2	Fuel and oil leak	—
	3	Tire pressure, wear and damage	42 55
	4	Engine oil level	51
	5	Fuel level	52
	6	Bonnet screen	53
	7	Transmission fluid level	53
	8	Brake play	65
	9	Air cleaner primary element	60
	10	Bottom dust cover	54
	11	Area around engine	54

(Continued)

	No.	Check item	Ref. page
Walking around the machine	12	Machine body cleaning	—
	13	Clean around the mower belt.	—
	14	Clean the hot surface. For example, exhaust manifold or muffler.	—
Mower	1	Check all hardware.	—
	2	Make sure all pins are in place	21
	3	Mower deck cleaning	76
	4	Greasing <ul style="list-style-type: none"> <li>• Universal joint</li> <li>• 3 spindle shafts</li> <li>• Belt tension pulley</li> <li>• Belt tension pivot</li> </ul>	55
	5	Oil leak	57
	6	Make sure blade bolts are tight	76
	7	Blades and belt wear or damage	76
While sitting in the operator's seat	1	Motion control lever	78
	2	Parking brake	65
	3	Other movable parts	56
Turning the key switch "ON"	1	Performance of the Easy Checker™ light	26
Starting the engine	1	Color of the exhaust fumes	—
	2	Check for abnormal noise and vibration.	—
	3	Engine start system/OPC system. If either of these do not operate properly, contact your local KUBOTA Dealer immediately.	56
Others	1	Check the areas where previous trouble was experienced.	—

## 1. Checking the engine oil level

### WARNING

To avoid serious injury or death:

- Always stop the engine and remove the key before checking the oil.

1. Check the engine oil before starting and 5 minutes or more after the engine has stopped.
2. Wipe the dipstick area clean.
3. To check the oil level, remove the dipstick, wipe it clean, replace it, and draw it out again. Check to see that the oil level is between the 2 notches.

4. Add new oil to the prescribed level at the oil port if necessary.

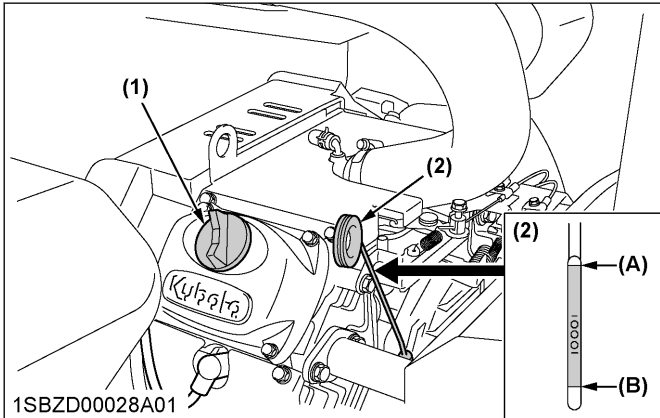

(1) Engine oil port  
(2) Oil level dipstick

(A) "UPPER LEVEL"  
(B) "LOWER LEVEL"

**IMPORTANT :**

- When using a different brand or viscosity oil from the previous one, remove all of the old oil and the oil filter. Never mix 2 different types of oil.
- Use the proper SAE engine oil according to the ambient temperature.  
(See LUBRICANTS AND FUEL on page 47.)

**2. Checking the amount of fuel and refueling**

**! WARNING**

To avoid serious injury or death:

- Park the machine on a firm and level surface.
- Apply the parking brake.
- Handle the fuel carefully. If the engine is running, do not fill the fuel tank. If the engine is hot, let the engine cool down several minutes before adding fuel.
- Do not smoke while filling the fuel tank or servicing the fuel system. Fill the fuel tank only to the bottom of the filler neck. Do not fill until completely full. The empty space in the tank allows gasoline to expand when it heats up.
- Never remove the fuel tank cap or add fuel when the fuel tank is hot.



1SFRT00004A01

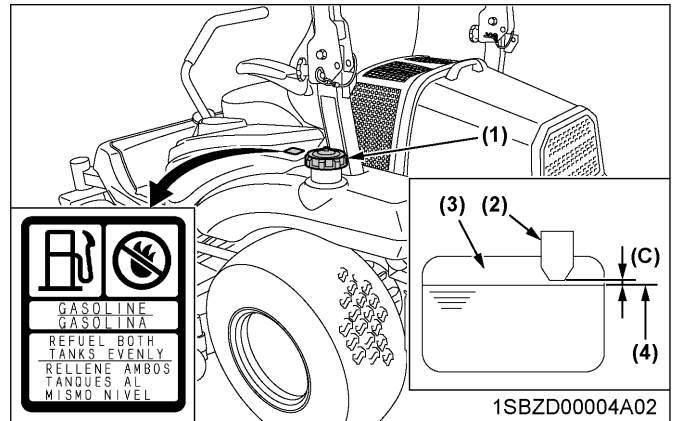

(1) Fuel tank cap  
(2) Fuel tank filler neck  
(3) Empty space  
(4) Max. fuel level

(C) Clearance  
(Fuel level is under the filler neck.)

1SBZD00004A02

Check the fuel level. Take care that the fuel tank does not become empty.

Fuel tank capacity	48 L (12.7 U.S.gals.)
--------------------	-----------------------

**IMPORTANT :**

- Do not mix oil with gasoline.
- Do not use the fuel cap other than KUBOTA approved one.
- Do not permit dirt or trash or water to get into the fuel system.
- Be careful not to empty the fuel tank otherwise air will enter the fuel system, necessitating bleeding before next engine start.
- Be careful not to spill fuel during refueling. If a spill should occur, wipe it off at once, or it may cause a fire.

Use only unleaded gasoline with an octane rating index of 87 or higher may be used.

**NOTE :**

- Use fuel within approximately 30 days after purchase to avoid deterioration in fuel quality, or add fuel stabilizer to keep fuel fresh and stabilized.
- Fuel blend differs from season to season for the best seasonal engine performance. To prevent

engine performance troubles such as vapor lock or hard starting, use fuel within the season in which the fuel is purchased.

- Infrequent use of the engine during a season can make fuel stale in the fuel tank of the machine. Stale fuel condition can cause engine performance troubles by varnish and plugged carburetor components.
- Seal the fuel storage container tightly and store it out of sunlight and heat to prevent fuel degradation.
- Condensation in the fuel tank may occur because of various operating or environmental conditions. To reduce condensation and avoid affecting machine operation, fill the fuel tank at the end of daily operations.

#### IMPORTANT :

- Do not use old fuel.

#### (Use of alcohol mixed gasoline (gasohol))

Use "gasohol" only when the ethanol additive is less than 10% of the fuel. The use of methanol additive is not recommended. For the best results, use unleaded fuel with a minimum of 87 octane.

### 3. Checking transmission fluid level

#### WARNING

To avoid serious injury or death:

- Allow the transmission case to cool down sufficiently when cleaning its surface.

1. Park the machine on a flat surface, lower the implement to the ground and shut off the engine and remove the key.  
Allow the machine to idle for 1 to 3 minutes, and then check fluid.
2. Raise and lock the operator's seat.
3. To check the oil level, draw out the dipstick, wipe it clean, replace it, and draw it out again. Check to see that the oil level lies between the 2 notches.  
If the level is too low, add the new oil to the prescribed level at the oil inlet.  
(See LUBRICANTS AND FUEL on page 47.)

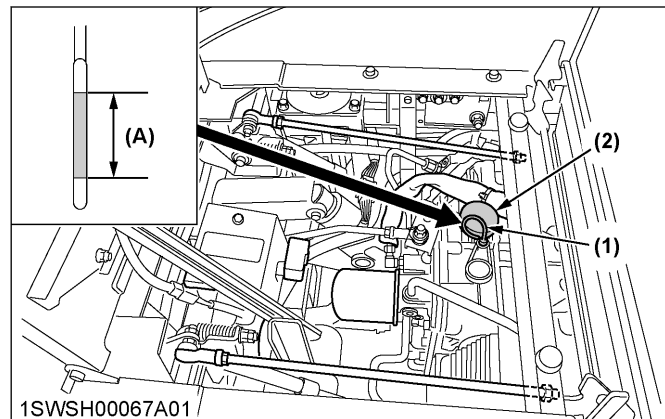

- 1SWSH00067A01
- (1) Oil level dipstick  
(2) Oil plug and breather cup
- (A) Oil level is acceptable within this range.

#### NOTE :

- If oil level is low, do not run engine.  
Add the new oil to the prescribed level at the oil inlet.

### 4. Checking and cleaning bonnet screen and air intake area to prevent overheating

#### WARNING

To avoid serious injury or death:

- Be sure to stop the engine and remove the key before checking and cleaning.
- Engine components can get extremely hot from operation. To prevent severe burns, do not touch these areas while the engine is running, or immediately after it is turned off.
- Never operate the engine without heat shields or guards.

#### IMPORTANT :

- The bonnet screen and air intake area must be clear of debris to prevent the engine from overheating.

Daily or after every 5 hours of operation, check to be sure the air intake screen and the air intake area are clean.

Dirt or chaff around the air intake screen and air intake area or the engine cooling area decrease cooling performance.

1. Remove all foreign materials from the bonnet screen.
2. Open the hood.
3. Remove the dust and all foreign materials from the air intake area between the transmission and the engine dust cover.
4. Clean the engine shroud panel as necessary. For this, refer to EVERY 100 HOURS on page 60.



- Each time the bonnet screen is covered with grass and foreign materials during operation, rub it off the screen with hand. Check the air intake area from time to time if grass accumulates.

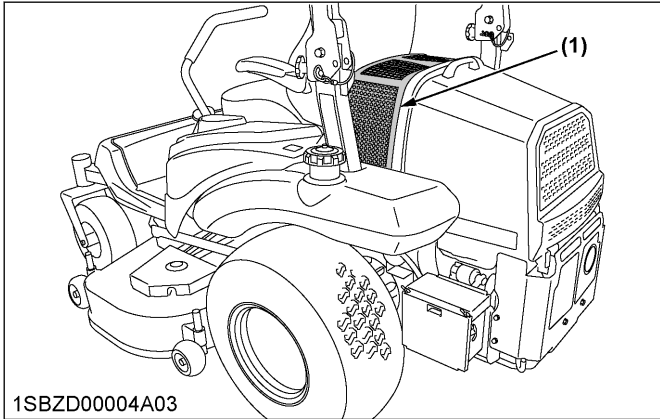

(1) Bonnet screen

### 5. Checking and cleaning bottom dust cover

- Open the hood and oil cooler cover. The bottom dust cover is connected with the bottom clean lever. Check dust on the bottom dust cover.
- If the dust or chaff has accumulated on the bottom dust cover, push down the bottom clean lever several times.

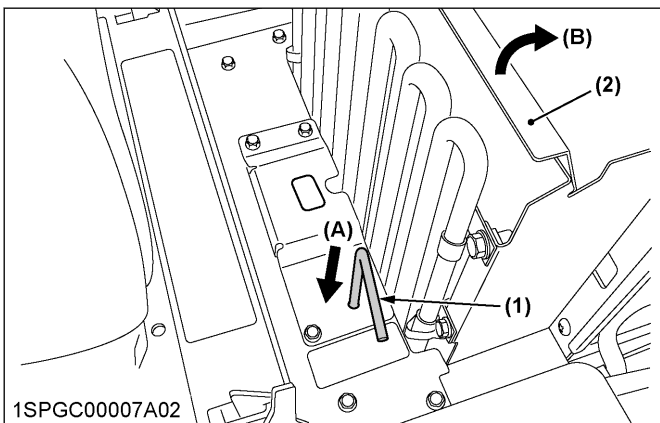

(1) Bottom clean lever (A) "PUSH DOWN"  
 (2) Oil cooler cover (B) "OPEN"

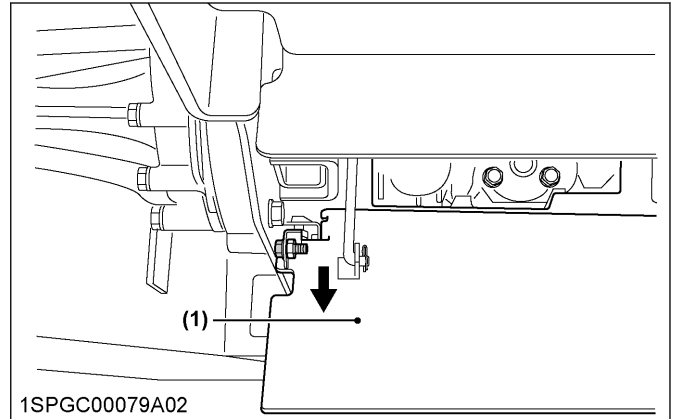

(1) Bottom dust cover

- Open the oil cooler cover and make sure there is no dust and foreign material on the bottom dust cover. After cleaning, close the hood.

### 6. Checking and cleaning area around engine to prevent overheating

#### **! WARNING**

To avoid serious injury or death:

- Engine components can get extremely hot from operation. To prevent severe burns, do not touch these areas while the engine is running, or immediately after it is turned off. Never operate the engine without heat shields or guards.

#### **! CAUTION**

To avoid personal injury:

- Be sure to stop the engine and remove the key before cleaning.

#### IMPORTANT :

- Area around engine must be clean to prevent the engine from overheating.
- Under the exhaust muffler must be clear of debris after cleaning area around engine.

- If the dust or chaff has accumulated between the engine and frame, remove them by hand or air blow.

**Left side**

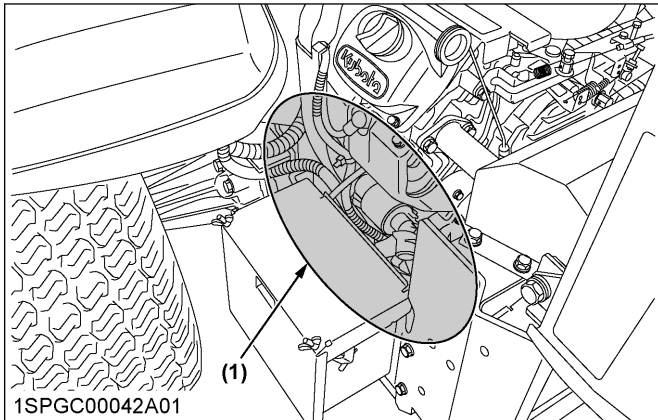

(1) Area around engine

**Right side**

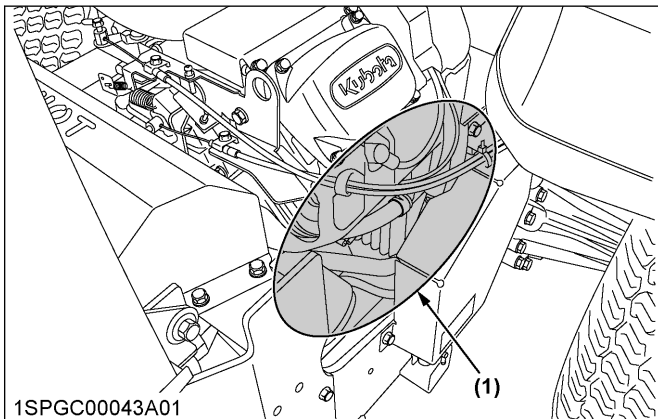

(1) Area around engine

**7. Checking the tire pressure**

**! WARNING**

To avoid serious injury or death:

- Do not attempt to mount a tire on a rim. This should be done by a qualified person with the proper equipment.
- Always maintain the correct tire pressure. The inflation pressure in the front tires rises quickly when using compressed air. Do not inflate the tires above the recommended pressure shown in the operator's manual.

**IMPORTANT :**

- Do not use tires larger than specified.

**7.1 Inflation pressure**

Even though the inflation pressure is factory-set to the prescribed level, it naturally drops slowly in the course

of time. Therefore, check it everyday and inflate as necessary.

	Tire sizes	Recommended inflation pressure
Front	15 × 6.0 - 6, (non flat tire) rib	—
Rear	26 × 12.0 - 12, 4PR turf	120 kPa (1.2 kgf/cm <sup>2</sup> , 17 psi)

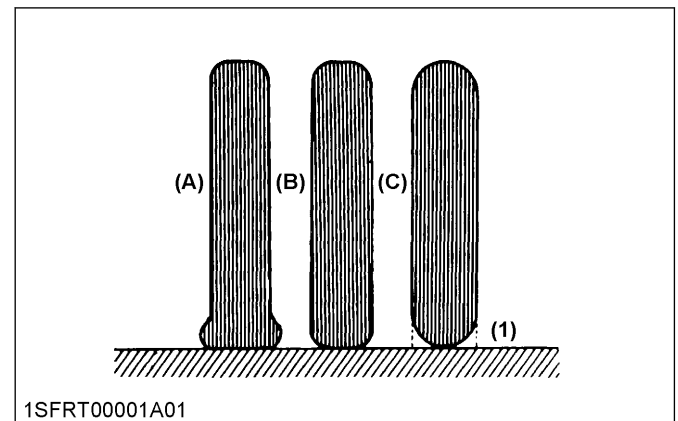

(1) Ground  
(A) "INSUFFICIENT" (B) "NORMAL" (C) "EXCESSIVE"

**8. Lubricating all grease fittings**

**! WARNING**

To avoid serious injury or death:

- Be sure to stop the engine and remove the key before greasing.

Grease the following location.

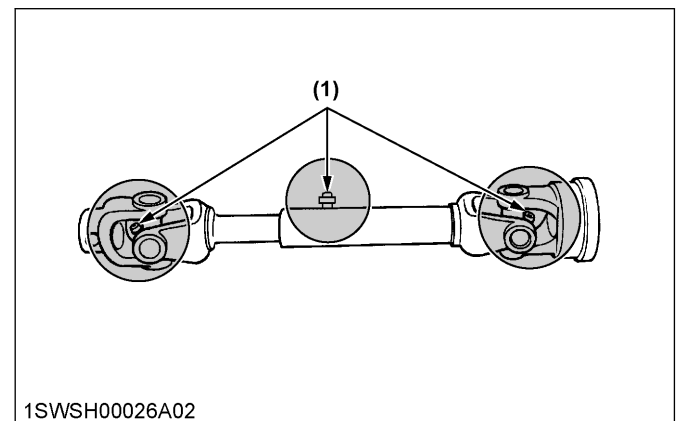

(1) Mower universal joint

RCK60P

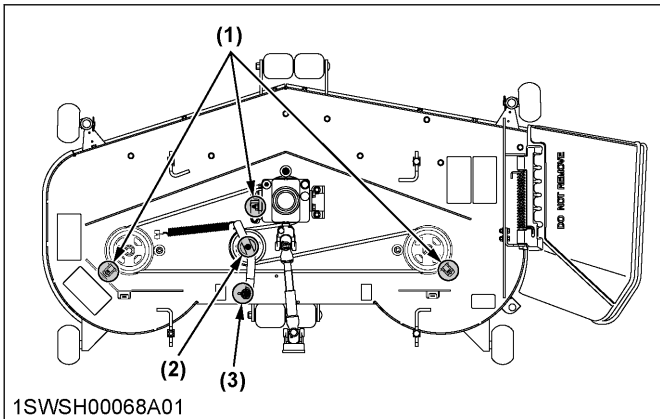

- (1) Spindle shaft
- (2) Belt tension pulley
- (3) Belt tension pivot

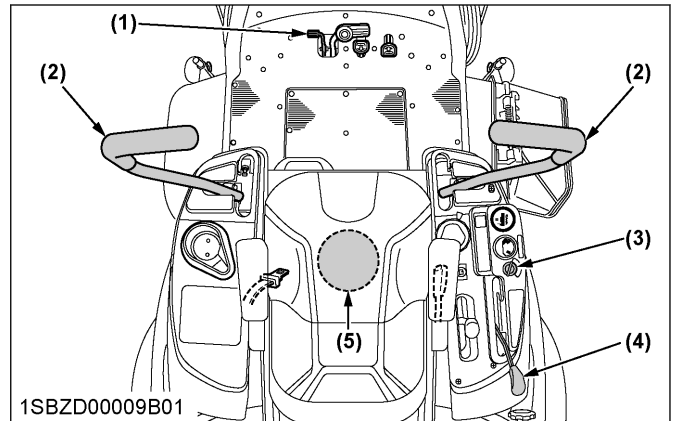

- (1) Parking brake lock pedal
- (2) Motion control lever
- (3) Key switch
- (4) PTO lever
- (5) Seat switch

### 9. Checking movable parts

If any of the movable parts, such as levers and pedals, is not smoothly moved because of rust or anything sticky, do not attempt to force it into motion. In the above case, remove the rust or the sticky thing, and apply oil or grease on the relevant spot. Otherwise, the machine may get damaged.

## EVERY 50 HOURS

### 1. Checking the engine start system

The engine start system in your machine is designed to protect you while operating. Check the engine start system periodically. It is recommended to check the engine start system before daily operation.

**WARNING**

To avoid serious injury or death:

- Park the machine on a firm and level surface.
- Do not allow anyone near the machine while testing.
- If the machine does not pass one of the following tests, do not operate the machine. Consult your local KUBOTA Dealer.
- Sit on the operator's seat for all tests except for test 1.

**IMPORTANT :**

- Test the following before operating the machine:

#### Test 1 (operator not on the seat)

1. Securely set the parking brake.
2. Set the PTO lever to the "DISENGAGE" (OFF) position.
3. Set the motion control levers to the "NEUTRAL LOCK" position.
4. Turn the key switch to the "START" position.
5. The engine must not crank.

#### Test 2 (operator on the seat)

1. Do not set the parking brake (release it from test 1).
2. Set the PTO lever to the "DISENGAGE" (OFF) position.
3. Set the motion control levers to the "NEUTRAL LOCK" position.
4. Turn the key switch to the "START" position.
5. The engine must not crank.

#### Test 3 (operator on the seat)

1. Securely set the parking brake.
2. Shift the PTO lever to the "DISENGAGE" (OFF) position.
3. Hold the motion control levers and move them inward from the "NEUTRAL LOCK" position to the "NEUTRAL" position and then release the levers.
4. Turn the key switch to the "START" position.
5. The engine must not crank.

#### Test 4 (operator on the seat)

1. Securely set the parking brake.
2. Shift the PTO lever to the "ENGAGE" (ON) position.
3. Set the motion control levers to the "NEUTRAL LOCK" position.
4. Turn the key switch to the "START" position.
5. The engine must not crank.

**NOTE :**

- If the engine cranks in tests 1 through 4, consult your local KUBOTA Dealer to have the unit checked before operation.

**Test 5 (operator on the seat)**

1. Start the engine.
2. Keep the parking brake securely set.
3. Shift the PTO lever to the "DISENGAGE" (OFF) position.
4. Hold the motion control levers and move them inward from the "NEUTRAL LOCK" position to the "NEUTRAL" position and then release the levers.
5. The engine must shut off after a short time delay.

**IMPORTANT :**

- For this test only, the engine will shut off in a few seconds.

**NOTE :**

- If the engine remains running in Test 5, consult your local KUBOTA Dealer to have the unit checked before operation.

**2. Checking the OPC system**

The operator presence control (OPC) system in your machine is designed to protect you while operating. Check the OPC system periodically (daily is best) to test the function of the OPC system before operation.

**! WARNING**

To avoid serious injury or death:

- Park the machine on a firm and level surface.
- Do not allow anyone near the machine while testing.
- If the machine does not pass one of the following tests, do not operate the machine. Consult your local KUBOTA Dealer.

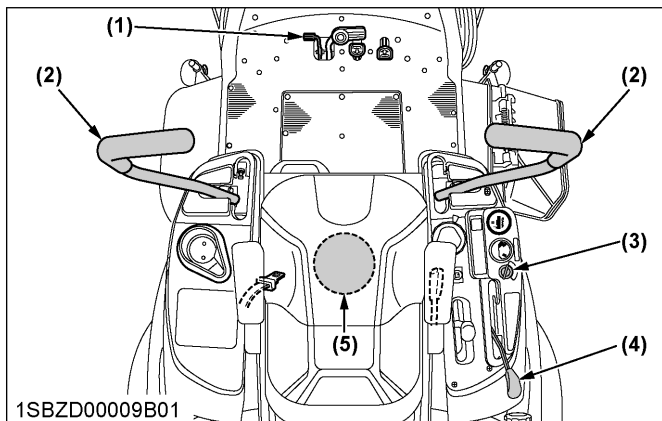

- (1) Parking brake lock pedal
- (2) Motion control lever
- (3) Key switch
- (4) PTO lever
- (5) Seat switch

**Test 1 (operator on the seat)**

1. Start the engine.
2. Do not set the parking brake.

3. Shift the PTO lever to the "DISENGAGE" (OFF) position.
4. Hold the motion control levers and move them inward from the "NEUTRAL LOCK" position to the "NEUTRAL" position and then release the levers.
5. Stand up. (Do not get off the machine.)
6. The engine must shut off.

**Test 2 (operator on the seat)**

1. Start the engine.
2. Do not set the parking brake.
3. Shift the PTO lever to the "ENGAGE" (ON) position.
4. Stand up. (Do not get off the machine.)
5. The engine must shut off.

**NOTE :**

- If the engine keeps running in tests 1 through 2, consult your local KUBOTA Dealer to have the unit checked before operation.

**3. Checking gear box oil level****! WARNING**

To avoid serious injury or death:

- Always stop the engine and remove the key before checking oil.

1. Park the machine on a flat surface and lower the mower to the ground.
2. To check the oil level, loosen the oil inlet plug with gauge, wipe it clean, reinstall it and loosen it again. Check to see if the oil level is between the notch and tip.
3. If the level is too low, check a label on the gear box to know the oil kind. Add new oil to the prescribed level at the oil inlet. (See LUBRICANTS AND FUEL on page 47.)

**IMPORTANT :**

- To prevent serious damage to gears, bearings and oil seals, do not mix different kinds of oil.

4. After checking, reinstall the oil inlet plug with gauge securely.

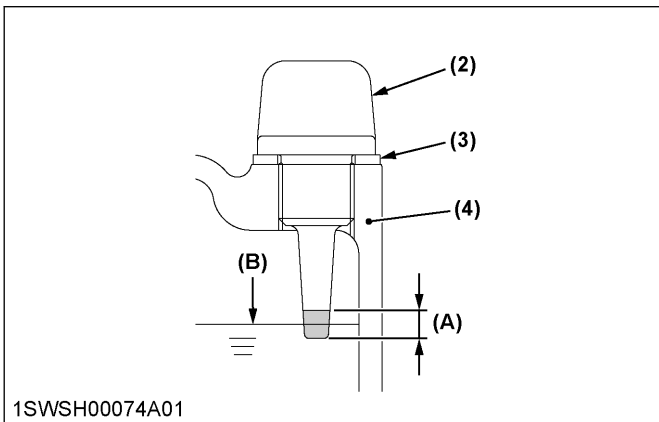
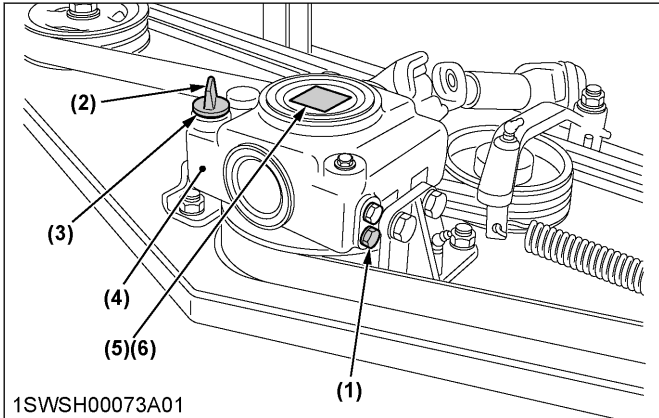

- (1) Drain plug
- (2) Oil inlet plug with gauge
- (3) Seal washer
- (4) Gear box
- (5) Rectangle shape label
- (6) Octagon shape label
- (A) Oil level is acceptable within this range.
- (B) Oil level

Label	(5)	(6)
Oil type	Gear oil	Gasoline engine oil
Capacity	0.4 L (0.42 U.S.qts.)	
SAE	SAE 90	SAE 10W-30
API Service Category	More than GL-3	SH or higher

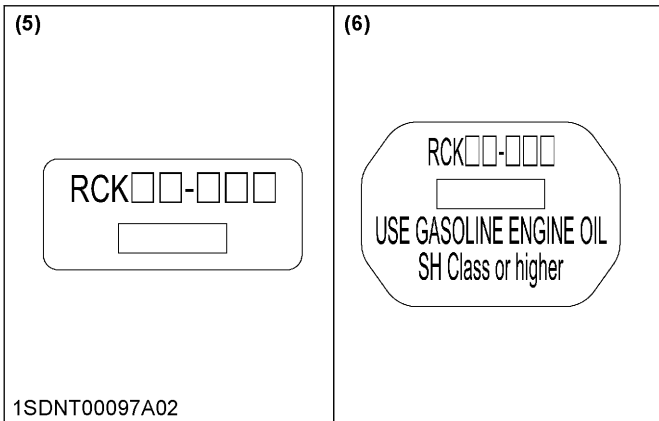

### 4. Greasing

**WARNING**  
 To avoid serious injury or death:  
 • Be sure to stop the engine and remove the key before greasing.

Apply a small amount of multipurpose grease to the following points every 50 hours:  
 If you operated the machine in extremely wet and muddy conditions, lubricate grease fittings more often.

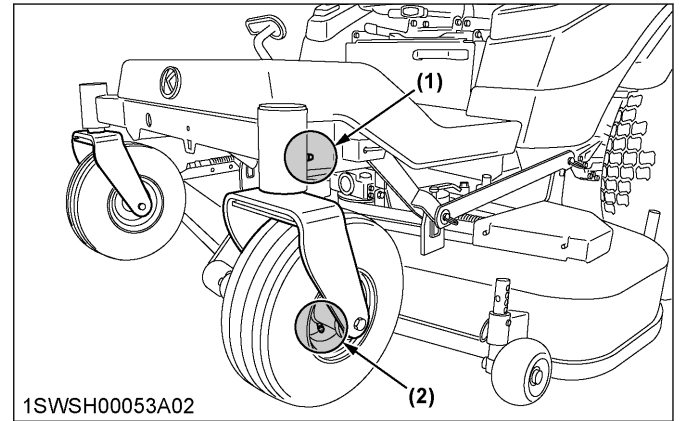

- (1) Front axle (LH, RH)
- (2) Front wheel (LH, RH)

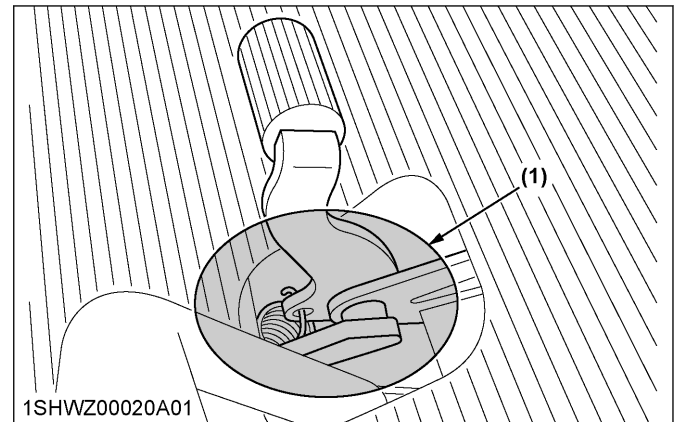

- (1) Parking brake lock pedal

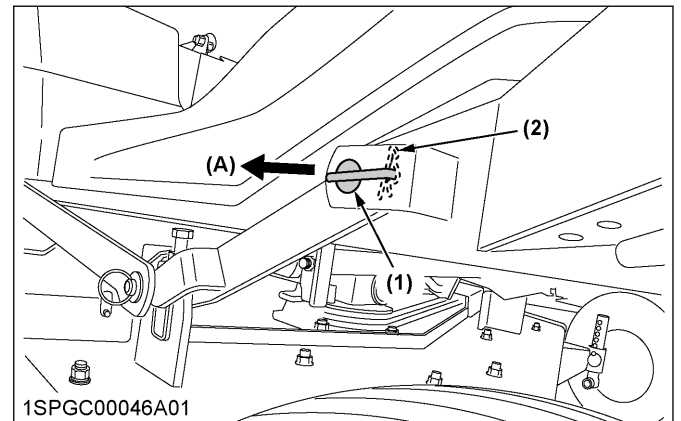

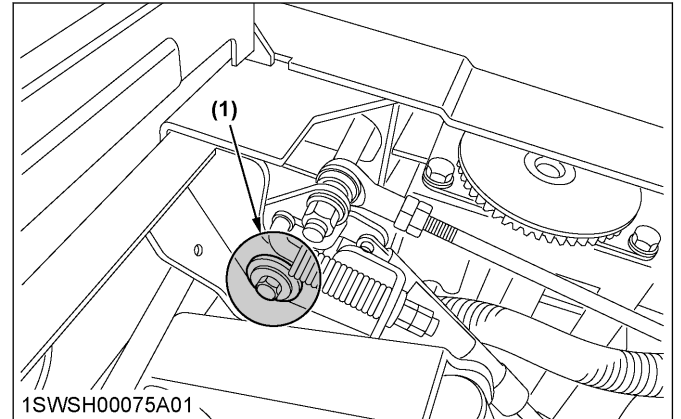
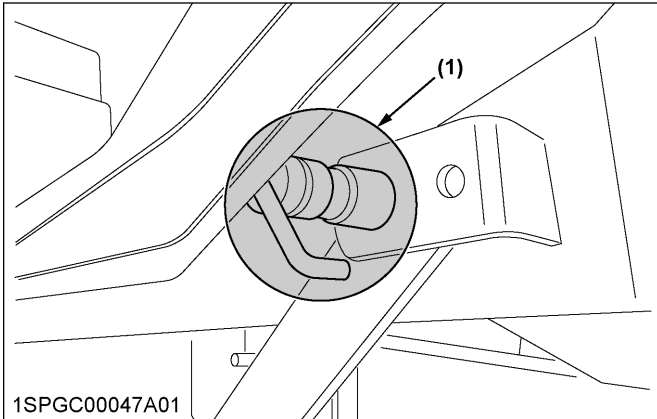

(1) Motion control lever pivot bushing (LH, RH)

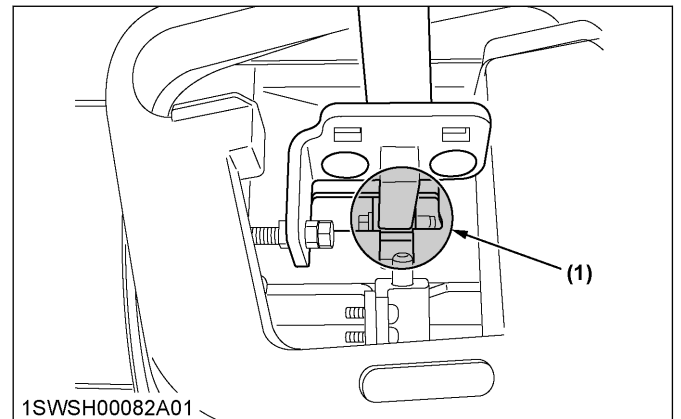
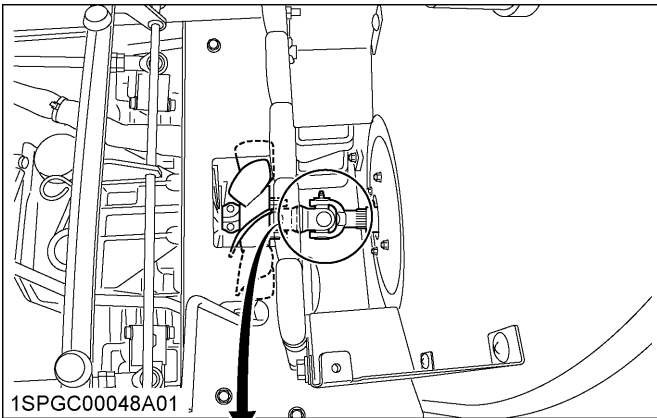

(1) Motion control lever contact position (LH, RH)

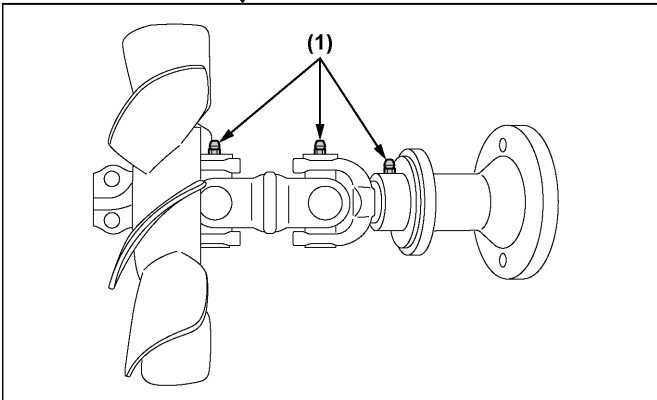

### 5. Oiling

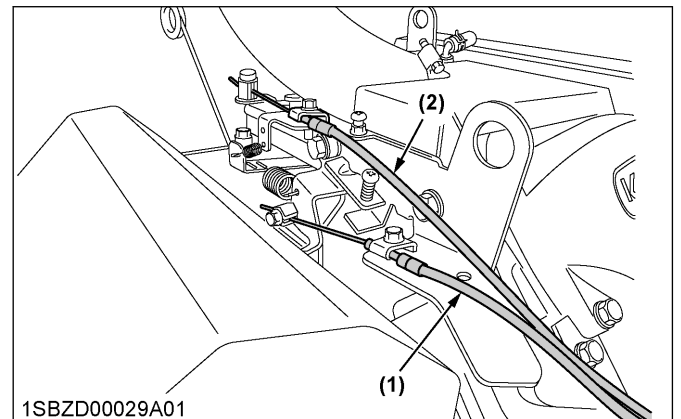

(1) Throttle cable (oil)  
(2) Choke cable (oil)

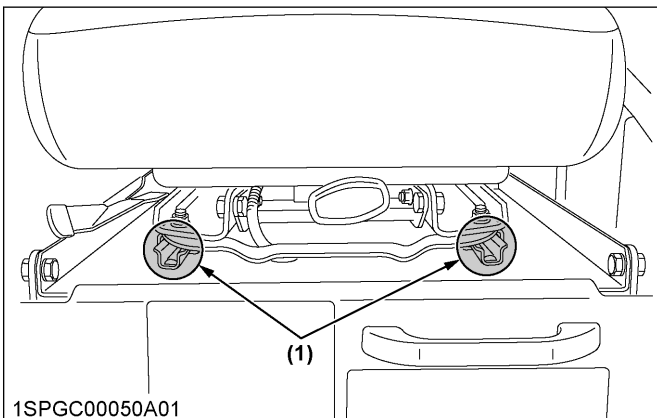

(1) Seat adjuster

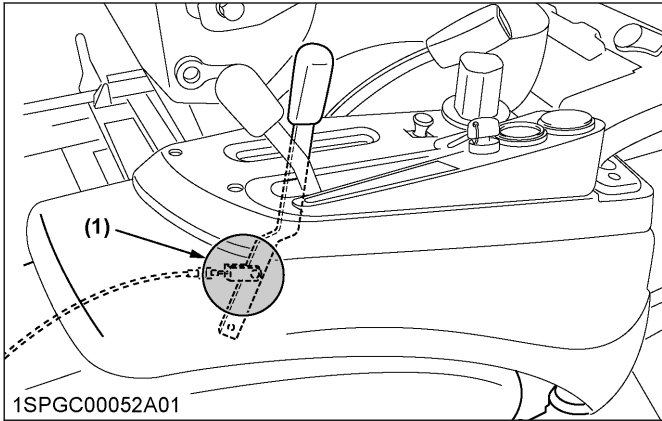

(1) Throttle cable (oil)

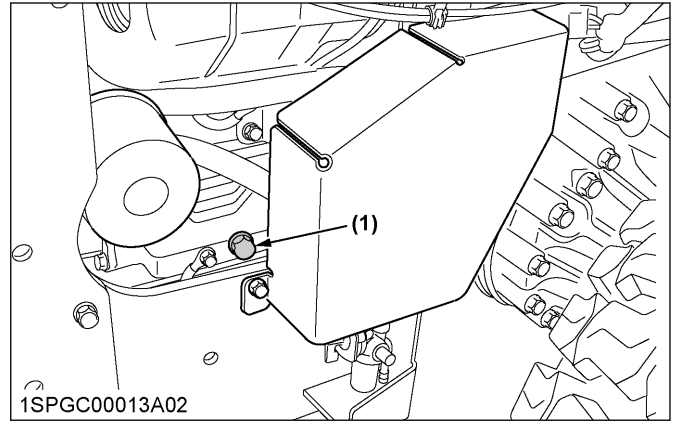

(1) Drain plug

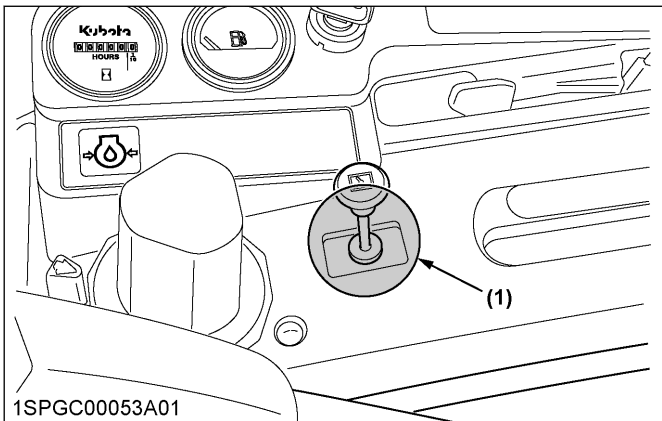

(1) Choke cable (oil)

3. To check the oil level. Remove the dipstick, wipe it clean, insert it and draw it out again. Check to see that the oil level is between the 2 marks.

## 2. Cleaning air cleaner primary element

1. Remove the air cleaner cover and primary element.
2. Clean the primary element:
  - When dry dust adheres to the element, blow compressed air from the inside, turning the element. Pressure of compressed air must be under 205 kPa (2.1 kgf/cm<sup>2</sup>, 30 psi).
  - When carbon or oil adheres to the element, soak the element in detergent for 15 minutes then wash it several times in water, rinse with clean water and dry it naturally. After element is fully dried, inspect inside of the element with a light and check if it is damaged or not.

## EVERY 100 HOURS

### 1. Changing engine oil

#### WARNING

To avoid serious injury or death:

- Be sure to stop the engine and remove the key before changing the oil.
- Allow engine to cool down sufficiently; oil can be hot and may cause burns.

1. To change the used oil, remove the drain plug at the bottom of the engine and drain the oil completely. The used oil can be drained out more easily if the engine is warm.
2. Fill with the new oil up to the upper notch on the dipstick.

- Replace air cleaner primary element:  
Once yearly or every 1000 hours whichever comes first.

**NOTE :**

- Check to see if the evacuator valve is blocked with dust.

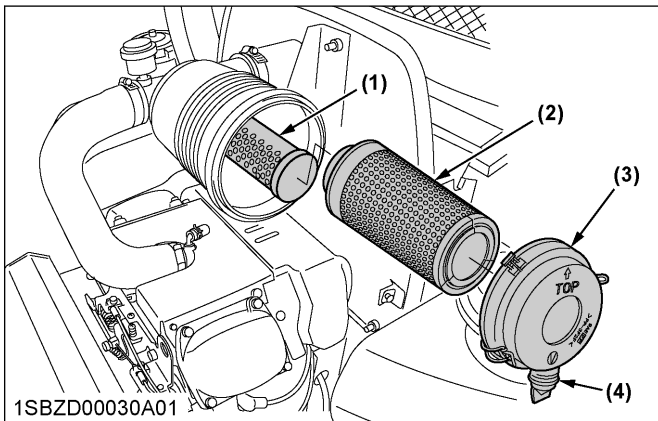

- 1SBZD00030A01
- Secondary (safety) element
  - Primary element
  - Cover
  - Evacuator valve

**NOTE :**

- The air cleaner uses a dry element, never apply oil.
- Do not run the engine with filter element removed.
- Be sure to refit the cover with the arrow **↑** (on the rear of cover) upright. If the cover is improperly fitted, evacuator valve will not function and dust will adhere to the element.
- Do not touch the secondary element except in cases where replacing is required.

**Evacuator valve**

Open the evacuator valve once a week under ordinary conditions - or daily when used in a dusty place - to get rid of large particles of dust and dirt.

### 3. Cleaning engine shroud panel

If you feel you are unable to make the following service correctly and safely, contact your local KUBOTA Dealer.

**⚠ WARNING**

To avoid serious injury or death:

- Make sure the engine is cool enough to touch before removing shrouds and other components.
- Always shield eyes and a face from air deposits and objects.

- Stop the engine and apply the parking brake.
- Open the hood.

- Loosen 2 screws (right and left) and remove the fan covers.

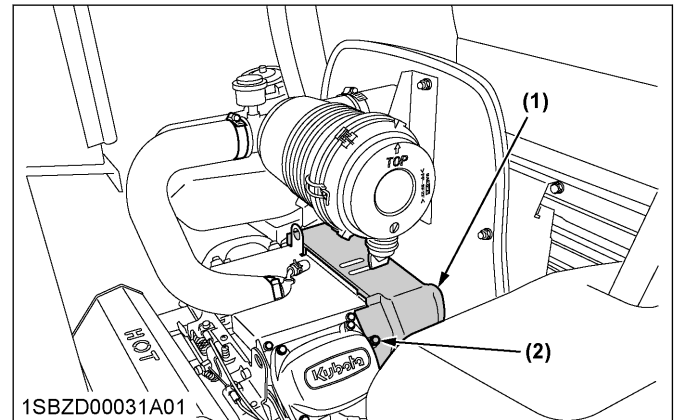

- 1SBZD00031A01
- Fan cover
  - Screw

- Loosen 4 M6 bolts (right and left) and remove the cover.

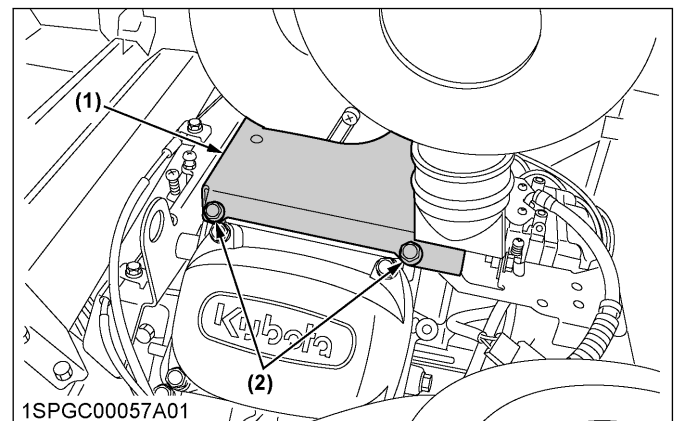

- 1SPGC00057A01
- Cover
  - M6 bolt

- Remove large debris around the cooling fin and then blow off small debris with a compressed air. Pressure of compressed air must be under 205 kPa (2.1 kgf/ cm<sup>2</sup>, 30 psi).

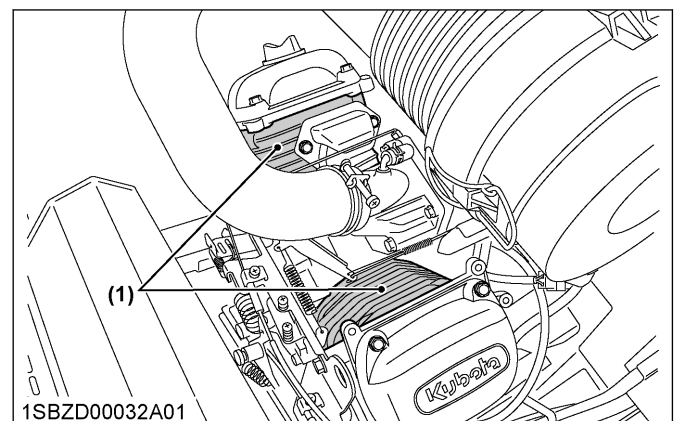

- 1SBZD00032A01
- Cooling fin



- Blow off the debris inside the fan cover as shown in the figure. Pressure of compressed air must be under 205 kPa (2.1 kgf/cm<sup>2</sup>, 30 psi).

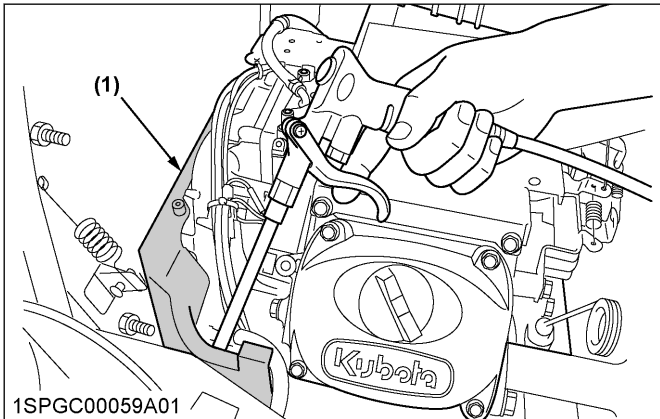

(1) Fan cover

- Open the oil cooler cover. Remove the debris on the surface of the dust cover by hand and blow off small debris with compressed air. Pressure of compressed air must be under 205 kPa (2.1 kgf/cm<sup>2</sup>, 30 psi).

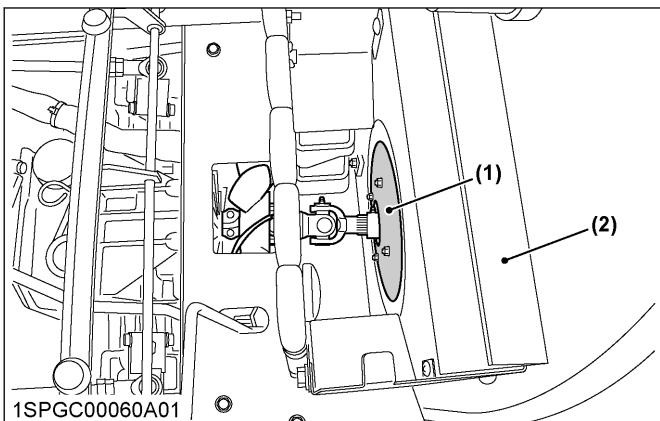

(1) Dust cover  
(2) Oil cooler cover

- Install the cover with 4 bolts and then the fan cover with 2 screws.
- Close the hood.

#### 4. Cleaning engine oil cooler fins

If you feel you are unable to make the following service correctly and safely, contact your local KUBOTA Dealer. This engine is equipped with an oil cooler. The style of the oil cooler is mounted on the blower housing. Pressure of compressed air must be under 205 kPa (2.1 kgf/cm<sup>2</sup>, 30 psi).

**WARNING**  
To avoid serious injury or death:

- Make sure the engine is cool enough to touch before removing shrouds and other components.
- Always shield eyes and a face from air deposits and objects.

- Stop the engine and apply the parking brake.
- Remove the cover of the carburetor fuel valve.

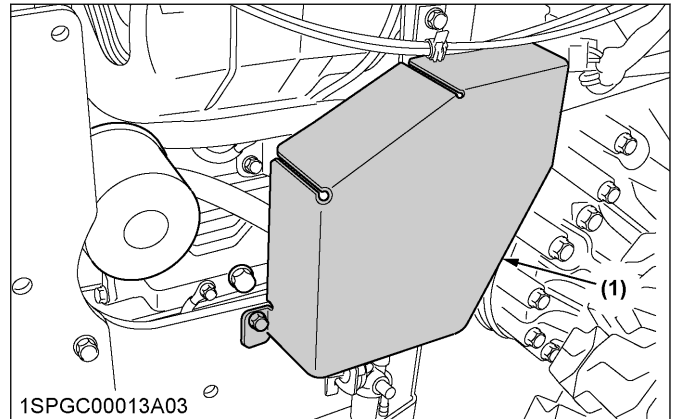

(1) Cover

- Loosen the 2 bolts for the engine oil cooler and remove the connector.

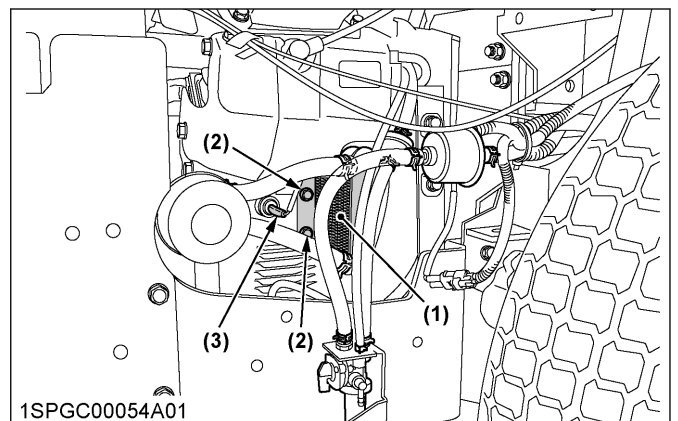

(1) Oil cooler  
(2) Bolt  
(3) Connector

## 4. Pull out the engine oil cooler.

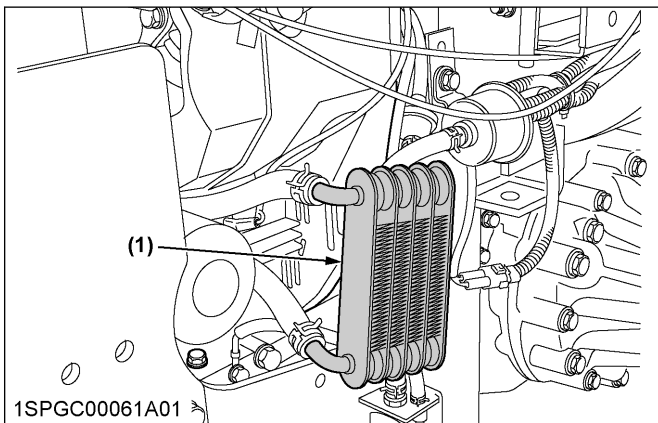

(1) Oil cooler

5. Remove large debris from both sides of the engine oil cooler fin by hand, and then blow off small debris with the compressed air. Pressure of compressed air must be under 205 kPa (2.1 kgf/cm<sup>2</sup>, 30 psi).
6. Remove the debris accumulated in the cooling air exit of the plate.

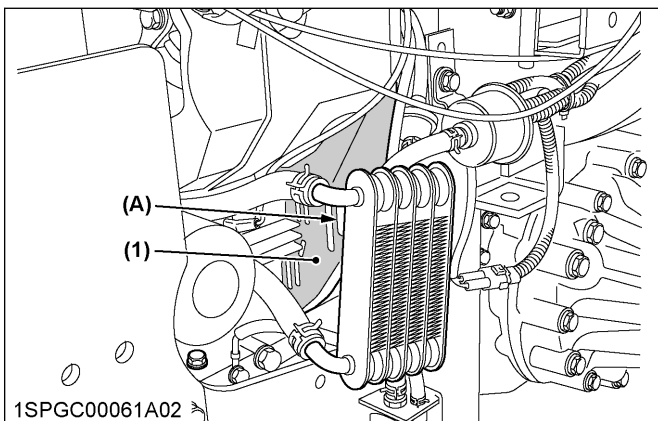

(1) Plate

(A) Cooling air exit

7. Put back the engine oil cooler in the original position, tighten bolts and connect the connector.
8. Install the cover of the carburetor fuel valve.

## 5. Checking the fuel filter

### WARNING

To avoid serious injury or death:

- Be sure to stop the engine and remove the key when attempting to make the following checks and changes.
- Never fail to check the fuel lines periodically. The fuel lines are subject to wear and aging. Fuel may leak out onto the running engine, causing a fire.

### IMPORTANT :

- When the fuel line is disconnected for maintenance or repairs, close both ends of the fuel line with a piece of clean cloth or paper to prevent dust and dirt from entering.
- Particular care must be taken not to allow dust and dirt to enter into the fuel pump. Entrance of even a small amount of dust or dirt causes premature wear and malfunction of the fuel pump and carburetor components.

The fuel line is made of rubber and ages regardless of service period.

See the following figures.

1. If the fuel line and clamps are found damaged or deteriorated, replace them.
2. Check fuel filters, if they are clogged by debris or contaminated with water, replace it.

3. If the dust or chaff has accumulated around the fuel filter, remove them by hand or air blow.

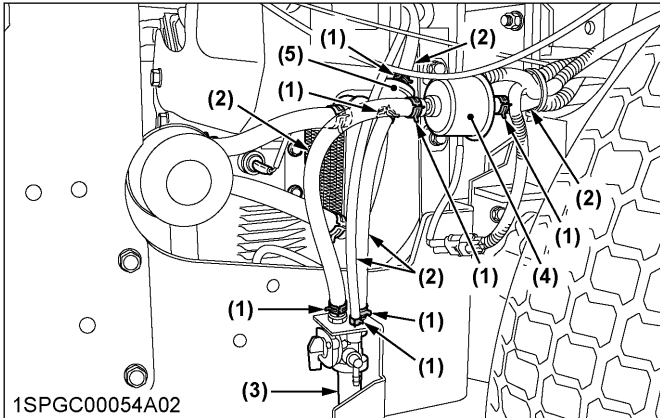

- (1) Pipe clamps
- (2) Fuel line
- (3) Fuel filter bowl
- (4) Fuel pump
- (5) Fuel filter

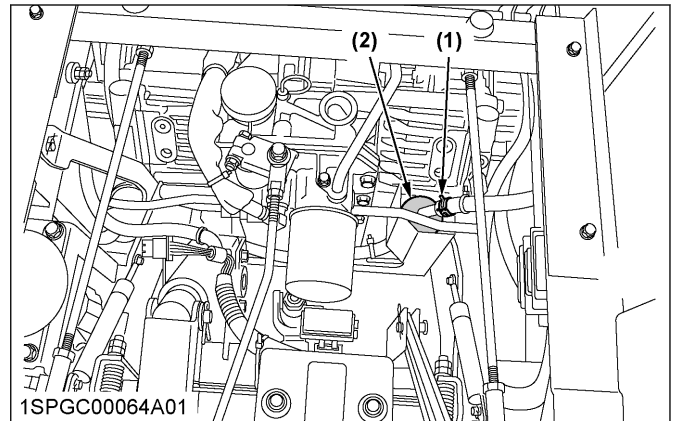

- (1) Pipe clamps
- (2) Fuel filter

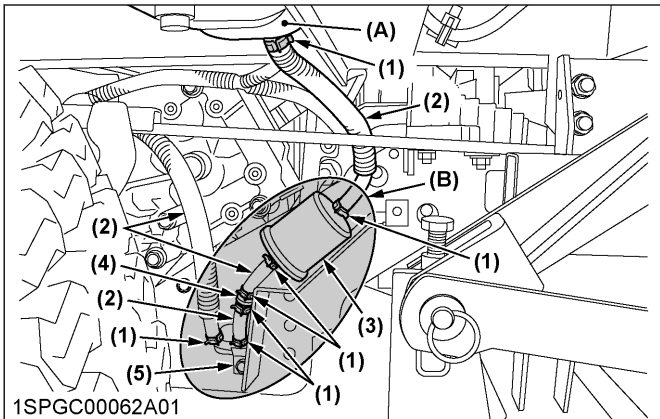

- (1) Pipe clamps
- (2) Fuel line
- (3) Fuel filter
- (4) One way valve
- (5) 3 way joint
- (A) Right fuel tank
- (B) Area around fuel filter

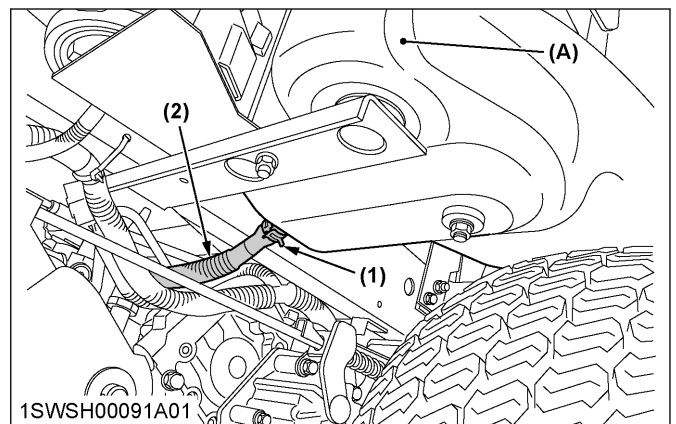

- (1) Pipe clamps
- (2) Fuel line
- (A) Left fuel tank

## 6. Cleaning fuel filter bowl

Before supplying fuel, clean the fuel filter bowl.

### IMPORTANT :

- If dirt or any other foreign matter is included in fuel, the filter element may be clogged earlier or water may be more likely to remain in the filter.
- If water remains in the fuel filter bowl, clean or replace the fuel filter bowl as early as possible.

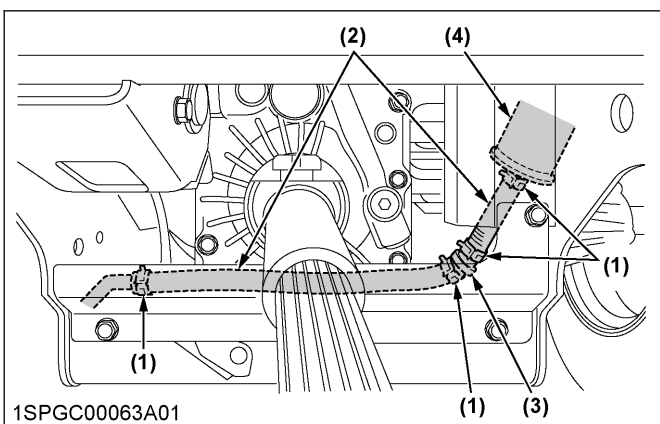

- (1) Pipe clamps
- (2) Fuel line
- (3) One way valve
- (4) Fuel filter

**Cleaning**

1. Change the carburetor fuel valve from the [RUN] (OPEN) position to the [STOP] (CLOSE) position.

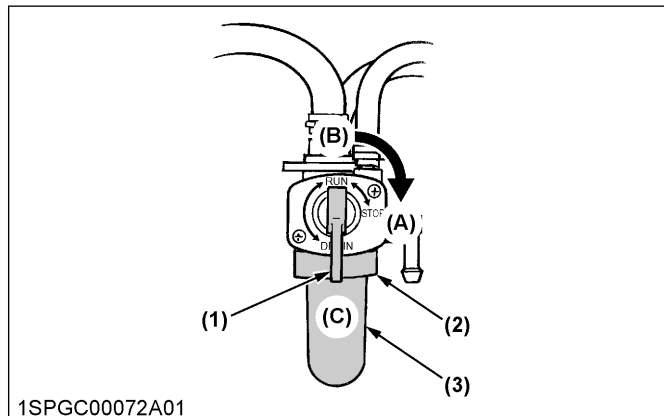

- (1) Carburetor fuel valve (A) [STOP] (CLOSE)  
 (2) Ring screw (B) [RUN] (OPEN)  
 (3) Fuel filter bowl (C) [DRAIN]

2. Loosen the ring screw and remove the fuel filter bowl.
3. Remove the element and rinse it with gasoline. If the element is excessively dirty, replace it.

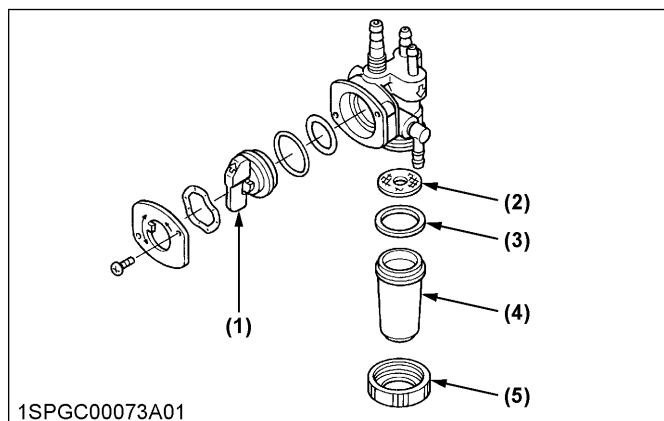

- (1) Carburetor fuel valve  
 (2) Element  
 (3) Packing  
 (4) Fuel filter bowl  
 (5) Ring screw

**IMPORTANT :**

- Take care not to damage and misplace the element and packing.
- If they are excessively dirty (clogged), they will be clogged again in short hours after cleaning.

4. Reassemble the packing and element while taking care that they are not contaminated with dirt.

**IMPORTANT :**

- If dirt is included in fuel, a failure can result.

**NOTE :**

- If the carburetor fuel valve is moved to the [DRAIN] position, the fuel will be drained through the drain port.

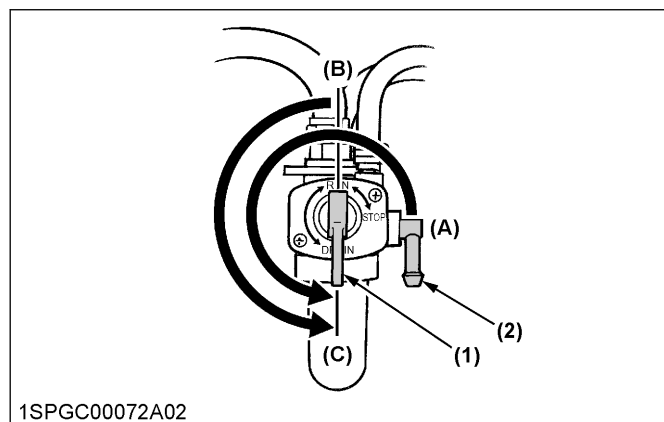

- (1) Carburetor fuel valve (A) [STOP] (CLOSE)  
 (2) Drain port (B) [RUN] (OPEN)  
 (C) [DRAIN]

**7. Adjusting parking brake**

If you feel you are unable to make the following service correctly and safely, contact your local KUBOTA Dealer.

**! WARNING**  
 To avoid serious injury or death:

- Park the machine on a firm and level surface.
- Stop the engine and chock the wheels before checking or adjusting.

**IMPORTANT :**

- Wrong adjustment may cause machine damage.

**7.1 Check brake spring**

1. Place the motion control levers to the "NEUTRAL LOCK" position.
2. Be sure to chock the rear wheels.
3. Apply the parking brake to the lock position.
4. Check the length of the brake springs on both sides.

(A): Proper brake spring length with the brake applied to the lock position	115 to 117 mm (4.53 to 4.61 in.)
---	-------------------------------------

**When the parking brake is locked.**

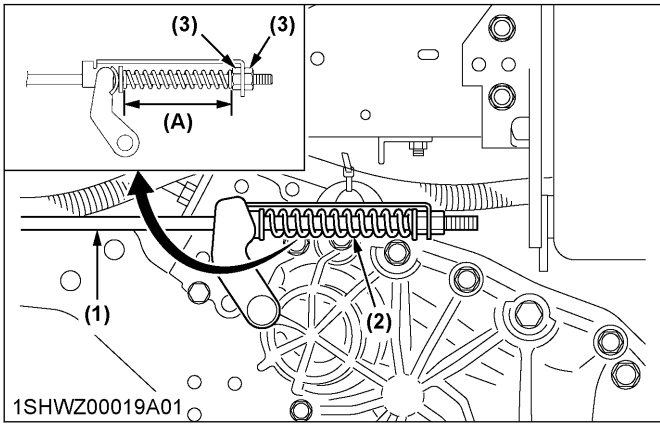

- (1) Brake rod
- (2) Brake spring
- (3) Lock nut
- (A) "Parking brake spring length"

5. If the length of the brake spring is not correct, adjust it.  
(See "Adjustment of brake spring length" as follows.)
6. Release the parking brake completely.
7. Hold the brake rod lightly.
8. Check the brake spring play.

(B): Proper brake spring play	The spring must have play.
	Reference: 0.5 to 1.0 mm (0.02 to 0.04 in.)

**When the parking brake is released.**

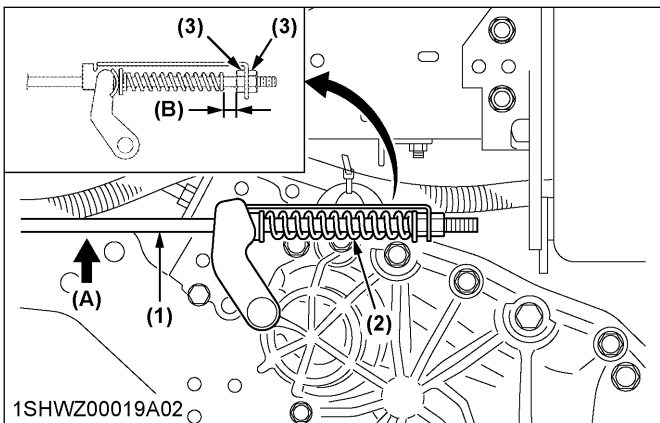

- (1) Brake rod
- (2) Brake spring
- (3) Lock nut
- (A) "Hold the brake rod"
- (B) "Parking brake spring play"

9. If the brake spring play is not correct, adjust it.  
(See "Adjustment of brake spring play" as follows.)

**Adjustment of brake spring length**

1. Place the motion control lever to the "NEUTRAL LOCK" position.
2. Apply the parking brake to the lock position.
3. Loosen the lock nuts.
4. Adjust the spring length to the recommendation.
5. Lock the nuts.

6. Check the brake spring play to the recommendation.  
If there is no play, adjust the brake spring play again.  
(See "Adjustment of brake spring play" as follows.)

7. Adjust the other side spring to the same dimension.

**Adjustment of brake spring play**

1. Place the motion control lever to the "NEUTRAL LOCK" position.
2. Be sure to chock the rear wheels.
3. Release the parking brake completely.
4. Loosen the lock nuts.
5. Hold the brake rod by hand.
6. Tighten the nut to the correct space between the end of the spring and the nut.
7. Lock the nuts.
8. Adjust the other side spring to the same dimension.

**7.2 Check on the slope**

1. Place the machine on a 17° ramp.
2. Apply the parking brake.
3. Place the motion control levers in "NEUTRAL LOCK" position and shut off the engine.
4. Check that the machine does not move.

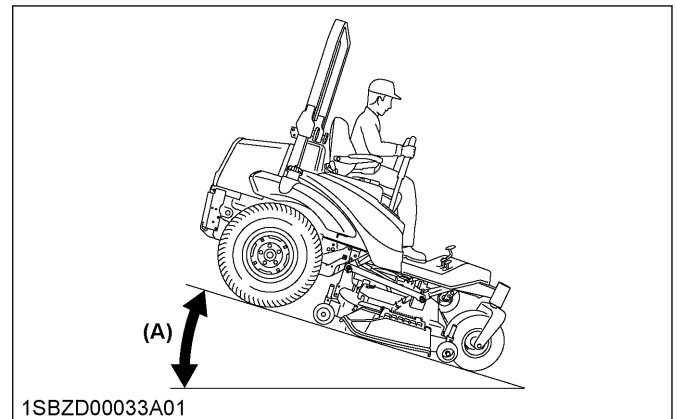

1SBZD00033A01  
(A) 17° ramp

**NOTE :**

- For parking brake test purposes, only use 17° ramp.

**8. Checking the battery condition**

**⚠ DANGER**

To avoid the possibility of battery explosion:  
For the refillable type battery, follow these instructions:

- Do not use or charge the refillable type battery if the fluid level is below the [LOWER] (lower limit level) mark. Otherwise, the battery component parts may prematurely deteriorate, which may shorten the battery's service life or cause an explosion.

- Check the fluid level regularly and add distilled water as required so that the fluid level is between the [UPPER] and [LOWER] levels.

**⚠ WARNING**

To avoid serious injury or death:

- Never remove the vent cap while the engine is running.
- Keep electrolyte away from eyes, hands and clothes. If you are splattered with electrolyte, wash it away completely with water immediately and get medical attention.
- Wear eye protection and rubber gloves when working around the battery.

**IMPORTANT :**

- Mishandling the battery shortens the service life and adds to maintenance costs. The original battery is maintenance free, but needs some servicing. If the battery is weak, the engine will be difficult to start and the lights will be dim. It is important to check the battery periodically.

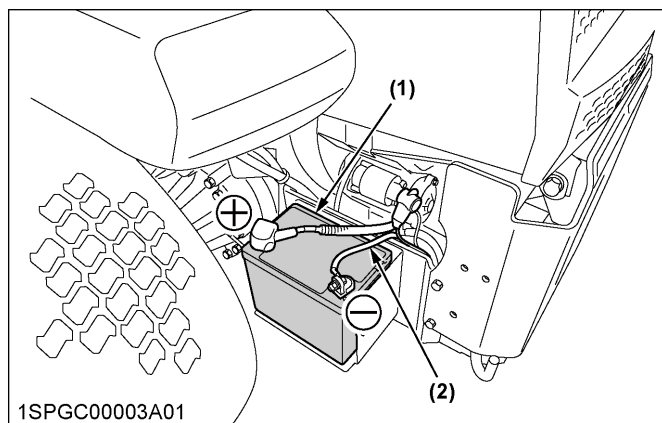

1SPGC00003A01

- (1) Battery
- (2) Ground cable
- (+) Positive terminal
- (-) Negative terminal

**8.1 Charging the battery**

**⚠ DANGER**

To avoid serious injury or death:

- When the battery is being activated, hydrogen and oxygen gases in the battery are extremely explosive. Keep open sparks and flames away from the battery at all times, especially when charging the battery.

**⚠ WARNING**

To avoid serious injury or death:

- When charging battery, ensure that the vent caps are securely in place (if equipped).

- When disconnecting the cable from the battery, start with the negative terminal first. When connecting the cable to the battery, start with the positive terminal first.
- Never check the battery charge by placing a metal object across the posts. Use a voltmeter or hydrometer.

(For accessible maintainable type batteries with removable vent caps.)

1. Make sure each electrolyte level is at the bottom of vent wells, if necessary add distilled water in a wellventilated area.

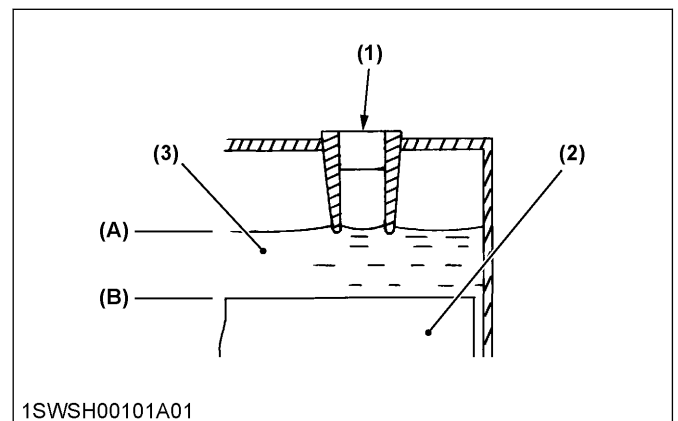

1SWSH00101A01

- (1) Vent well
- (2) Separator
- (3) Electrolyte
- (A) "HIGHEST LEVEL"
- (B) "LOWEST LEVEL"

2. The water in the electrolyte evaporates during recharging. Liquid shortage damages the battery. Excessive liquid spills over and damages the machine body.
3. To slow charge the battery, connect the battery positive terminal to the charger positive terminal and the negative to the negative, then recharge in the standard fashion.
4. A boost charge is only for emergencies. It will partially charge the battery at a high rate and in a short time. When using a boost-charged battery, it is necessary to recharge the battery as early as possible. Failure to do this will shorten the battery's service life.
5. When the specific gravity of electrolyte is between 1.27 and 1.29, the charging is completed.

6. When exchanging an old battery with new one, use a battery of equal specification shown in "SPECIFICATIONS".

(For non-accessible maintenance-free type batteries.)

Maintenance-free, non-accessible batteries are designed to eliminate the need to add water. Yet the volume of electrolyte above plates may eventually become depleted due to abnormal conditions such as high heat or improper regulator setting. Use a voltmeter to check the state of charge. (See reference chart below to determine if charging is necessary.)

Battery voltage	Reference state of charge
12.6	100% (Full charge)
12.4	75%
12.2	50%
12.0	25%
11.8	0%

### 8.2 Cleaning area around battery

**IMPORTANT :**

- Area around battery must be clean to prevent the electrical cables from rusting.

1. If the dust or chaff has accumulated around battery, remove them by hand or air blow.

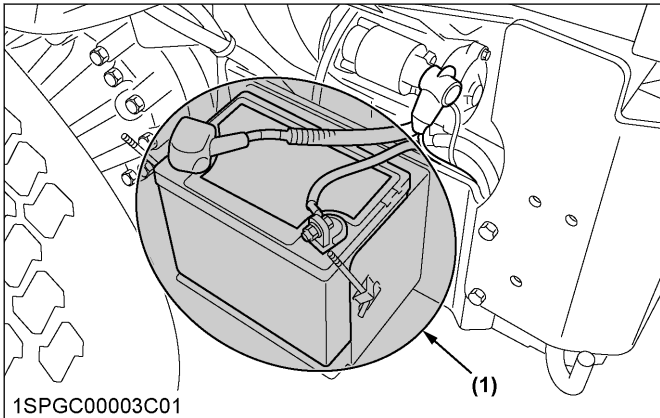

(1) Area around battery

### 9. Adjusting throttle cable

1. Move the throttle lever to the top position.

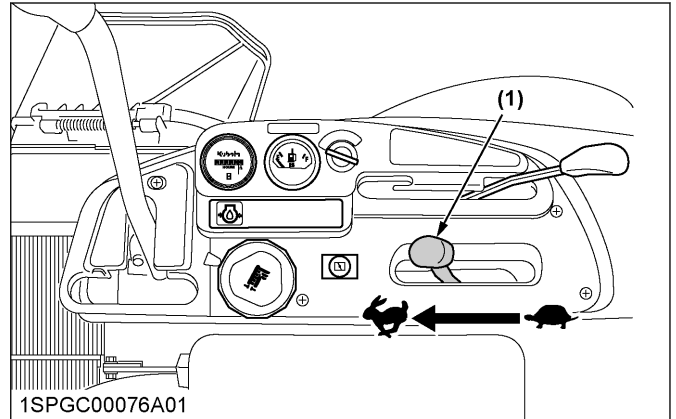

(1) Throttle lever

2. Make sure a part (2) is touching the restricting bolt (1).

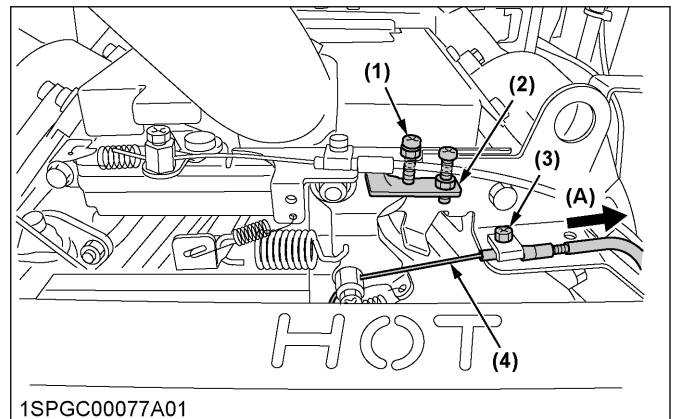

(1) Restricting bolt

(A) "PULL"

(2) Part

(3) Bolt

(4) Throttle lever cable

3. If not, loosen the bolt (3) and pull the throttle lever cable (4) in direction of the arrow (A) so that the part (2) would touch the restricting bolt (1). And then tighten the bolt (3).

### EVERY 150 HOURS

#### 1. Changing gear box oil

**! WARNING**

To avoid serious injury or death:

- Be sure to stop the engine and remove the key before changing the oil.

1. To drain the used oil, remove the drain plug and oil inlet plug with gauge at the gear box and drain the oil completely into the oil pan.
2. After draining reinstall the drain plug.
3. Remove the oil level check plug.

- Fill with the new oil up to the check plug port.  
(See LUBRICANTS AND FUEL on page 47.)  
Check the label on the gear box to know the oil kind before adding new oil.

**IMPORTANT :**

- To prevent serious damage to gears, bearings and oil seals, do not mix different kinds of oil.

- After filling reinstall the check plug and oil inlet plug with gauge securely.

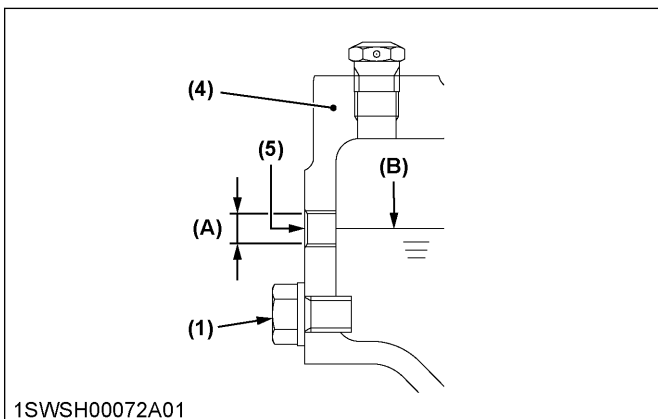
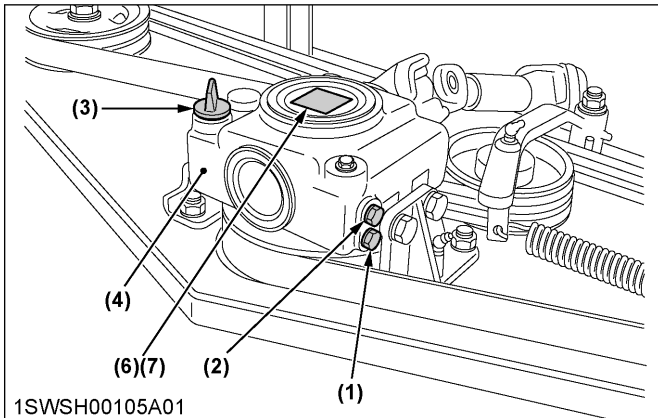

- |                               |  |
|-------------------------------|--|
| (1) Drain plug                | (A) Oil level is acceptable within this range. |
| (2) Check plug                | (B) Oil level                                  |
| (3) Oil inlet plug with gauge |  |
| (4) Gear box                  |  |
| (5) Check plug port           |  |
| (6) Rectangle shape label     |  |
| (7) Octagon shape label       |  |

Label	(6)	(7)
Oil type	Gear oil	Gasoline engine oil
Capacity	0.4 L (0.42 U.S.qts.)	
SAE	SAE 90	SAE 10W-30
API Service Category	More than GL-3	<b>SH</b> or higher

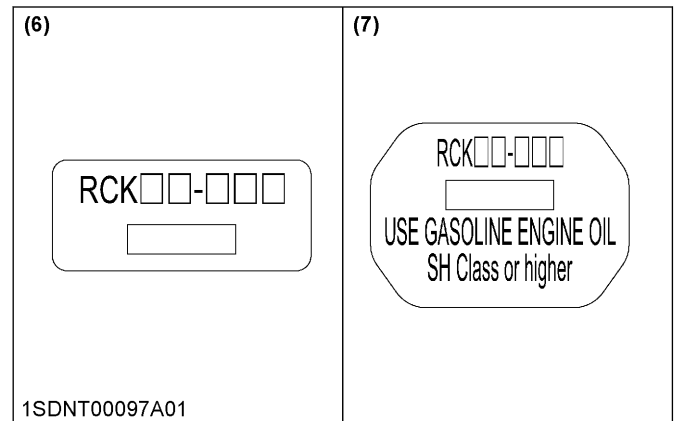

**EVERY 200 HOURS**

**1. Replacing the engine oil filter**

**⚠ WARNING**

To avoid serious injury or death:

- Be sure to stop the engine and remove the key before changing the oil and the oil filter.
- Allow the engine to cool down sufficiently. Oil can be hot and may cause burns.

The oil filter must be changed every 200 service hours.

- Apply a slight coat of oil onto the rubber gasket of new filter.
- Tighten the filter quickly until it contacts the mounting surface. Tighten filter by hand an additional 1/2 turn only.
- After the new filter has been replaced, the engine oil level normally lowers a little. Add engine oil to proper level. Check for oil leaks around filter gasket.

**NOTE :**

- To prevent serious damage to the engine, replacement element of the recommended type must be used. Use only a genuine KUBOTA filter or its equivalent.

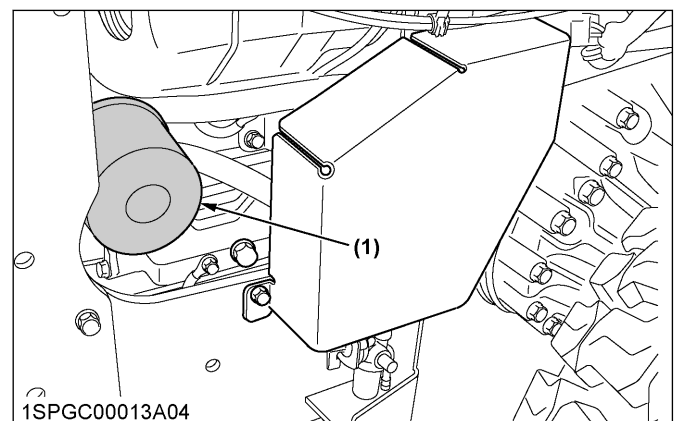

(1) Engine oil filter



## 2. Checking spark plug condition and gap

Remove the spark plugs, check condition, and reset the gap or replace with new plugs as necessary.

1. Open the hood.
2. Before removing spark plugs, clean the area around the base of the plug to keep dirt and debris out of the engine.
3. Disconnect the spark plug cap from spark plugs.
4. Use a spark plug wrench to remove the spark plugs.
5. Remove plugs and check its condition. Replace the plug if worn or reuse is questionable.
6. Inspect spark plugs for cracked porcelain, pitted electrodes, or other wear and damage. Replace the spark plug if necessary.

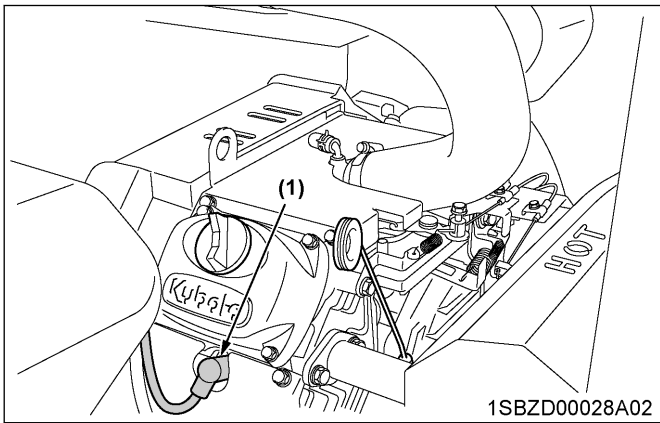

(1) Spark plug cap and spark plug

**NOTE :**

- Do not clean the spark plug in a machine using abrasive grit. Some grit could remain in the spark plug and enter the engine, which may cause extensive wear and damage.

Recommended spark plug	<b>NGK BPR6HS</b>
------------------------	-------------------

7. Check the gap using a wire feeler gauge. Adjust the gap from 0.6 to 0.7 mm (0.024 to 0.028 in.) by carefully bending the ground electrode.

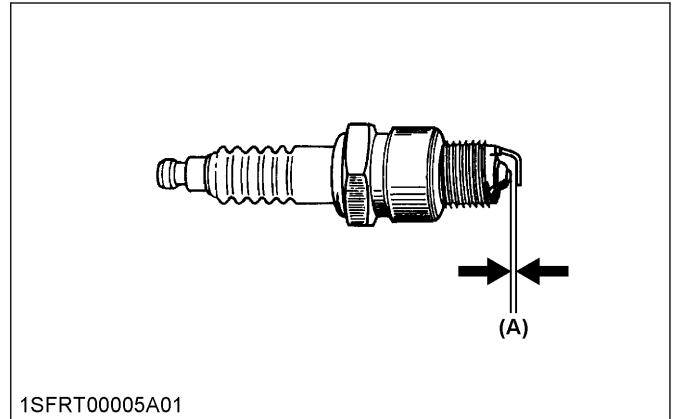

1SFRT00005A01

(1) 0.6 to 0.7 mm (0.024 to 0.028 in.)

8. Reinstall the spark plug into the cylinder head.

Tightening torque	9.8 to 19.6 N · m (7.2 to 14.5 lbf · ft)
-------------------	---

## 3. Replacing transmission oil filter (HST)

**! WARNING**

To avoid serious injury or death:

- Be sure to stop the engine and remove the key before changing the oil filter.
- Allow the transmission case to cool down sufficiently, as oil can be hot and may cause burns.

The oil filter must be changed every 200 service hours.

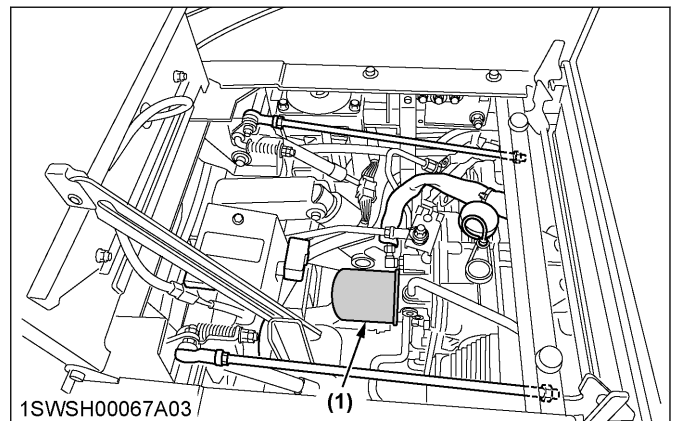

1SWSH00067A03

(1) Transmission oil filter (HST)

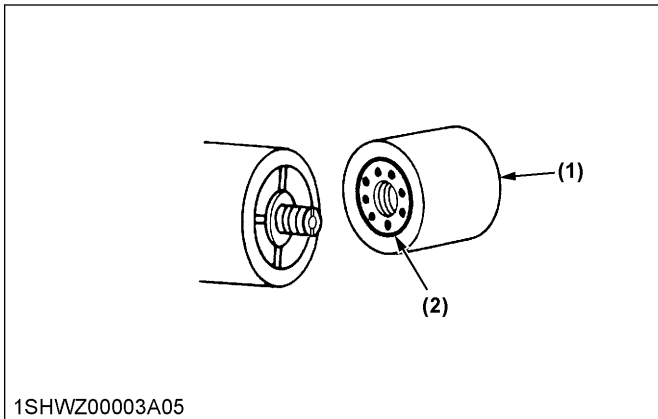

(1) Transmission oil filter (HST)  
 (2) Gasket

1. Place an oil pan underneath the oil filter. (Do not drain oil.)
2. Remove the oil filter by using the filter wrench.
3. Apply a slight coat of oil onto the gasket of new filter.
4. Tighten the filter quickly until it contacts the mounting surface. Tighten filter by hand an additional 1/2 turn only.
5. After the new filter has been replaced, the transmission fluid level normally lowers a little. Add fluid to proper level. Check for oil leaks around filter gasket.

**IMPORTANT :**

- To prevent serious damage or premature failure to the hydraulic system, use only a KUBOTA genuine filter.

### 4. Adjusting the motion control lever pivot

**! WARNING**

To avoid serious injury or death:

- Be sure to stop the engine and set the parking brake to "ON" before checking.

Proper lever free travel	2 to 15 mm (0.08 to 0.59 in.) on the lever
--------------------------	--

1. Set the motion control lever in "NEUTRAL" position.
2. Slightly move the lever back and forth and measure the free travel at the top of lever stroke.
3. If the proper free travel limits are exceeded, remove the fender and retighten only the upper nut to specified torque.

**NOTE :**

- If the motion control lever pivot bolt is maladjusted, motion control may be difficult.

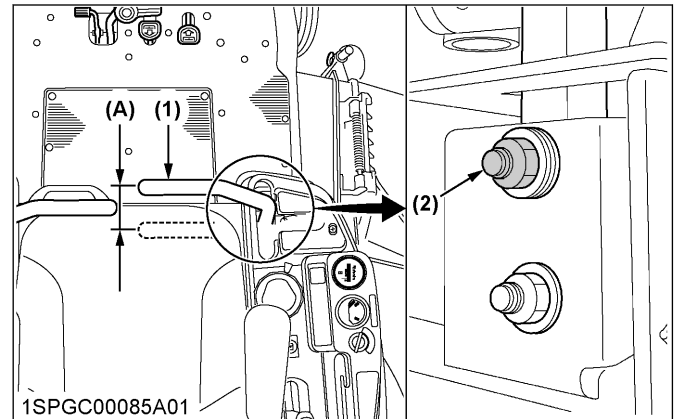

(1) Motion control lever (A) "FREE TRAVEL"  
 (2) Bolt, nut

Tightening torque	18.6 to 20.6 N·m (1.9 to 2.1 kgf·m, 13.7 to 15.2 lbf·ft)
-------------------	---

### 5. Cleaning engine shroud

Consult your local KUBOTA Dealer for this service.

## EVERY 400 HOURS

### 1. Changing transmission fluid and rear axle gear case oil (RH and LH)

**! WARNING**

To avoid serious injury or death:

- Park the machine on a firm and level surface.
- Be sure to stop the engine and remove the key before changing or checking the oil.
- Allow the transmission case to cool down sufficiently, as oil can be hot and may cause burns.

The fluid in the transmission case is also used for the hydrostatic drive system.

1. To drain the transmission oil, place oil pan underneath the transmission case and the rear axle gear case (RH and LH) and remove the drain plug at the bottom of the transmission case and the rear axle gear case (RH and LH).
2. After draining, reinstall the drain plugs.
3. Fill with UDT or **SUPER UDT** hydrostatic transmission fluid or its equivalent up to the upper line of the oil level dipstick.

**IMPORTANT :**

- It takes time to send the oil from the transmission case to the rear axle case (RH and LH).  
 Pour the regulated amount of oil slowly.

- After running the engine for a few minutes, stop it and check the oil level again; add oil to the prescribed level.

**IMPORTANT :**

- Operate only at low rpms immediately after changing the transmission fluid and filter.
- Keep the engine at medium speed for a few minutes to insure proper lubrication of all parts so there is no damage to transmission.

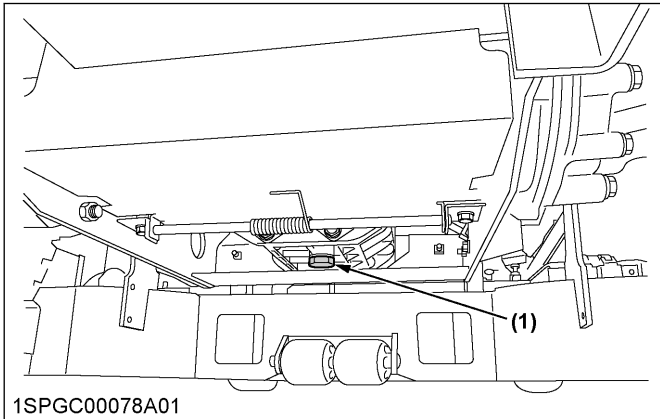

(1) Drain plug

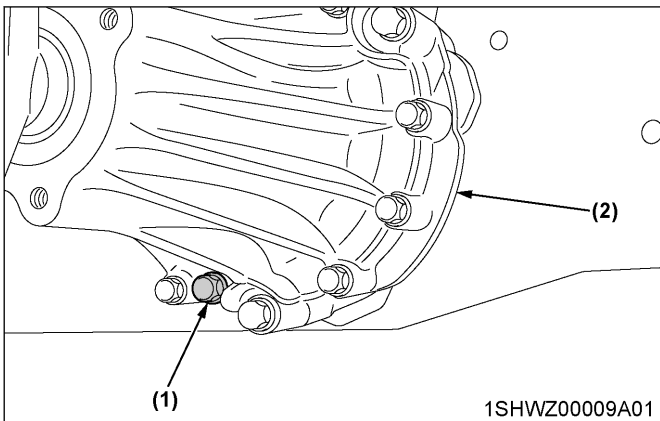

(1) Drain plug  
(2) Rear axle gear case LH

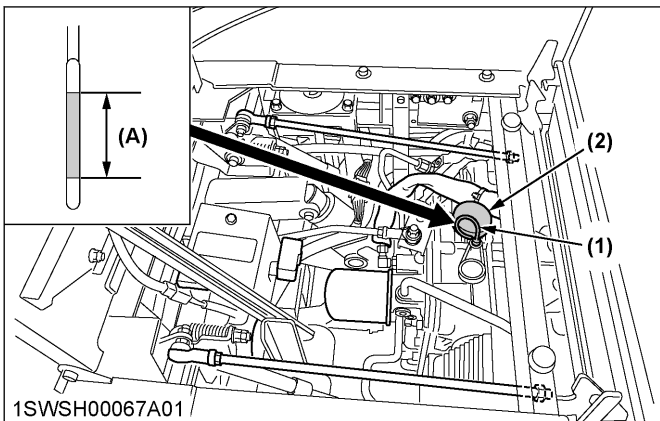

(1) Oil level dipstick (A) Oil level is acceptable within this range.  
(2) Oil plug and breather cup

## 2. Replacing hydraulic oil filter

**! WARNING**

To avoid serious injury or death:

- Be sure to stop the engine and remove the key before changing the oil filter.
- Allow the transmission case to cool down sufficiently, as oil can be hot and may cause burns.

The oil filter must be changed every 400 service hours.

- To drain the transmission oil, place oil pan underneath the transmission case and the rear axle gear case (RH and LH) and remove the drain plug at the bottom of the transmission case and the rear axle gear case (RH and LH).
- After draining, reinstall the drain plugs.
- Open the bottom dust cover by hand and lock it by loosening the restraining bolt.

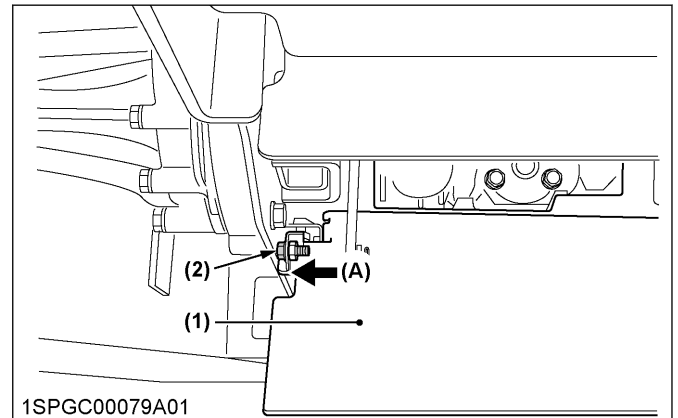

(1) Bottom dust cover (A) "LOOSEN"  
(2) Restraining bolt

4. Remove the oil filter by using the filter wrench.

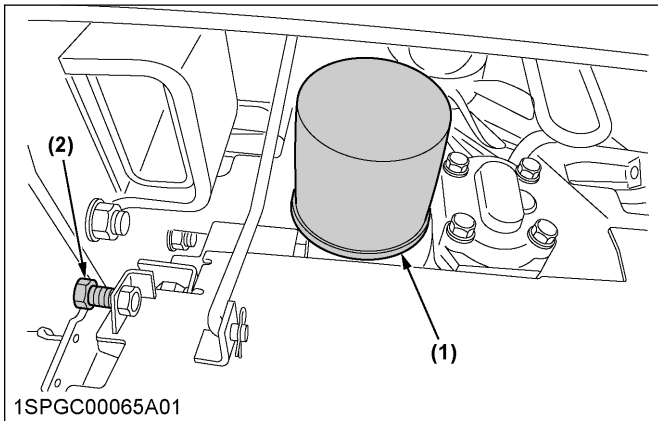

(1) Oil filter  
(2) Restraining bolt

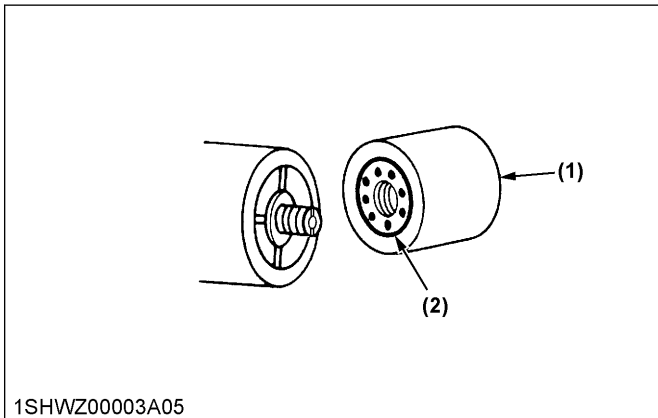

(1) Transmission oil filter (HST)  
(2) Gasket

5. Apply a slight coat of oil onto the gasket of new filter.
6. Tighten the filter quickly until it contacts the mounting surface. Tighten filter by hand an additional 1/2 turn only.
7. After the new filter has been replaced, the transmission fluid level normally lowers a little. Add fluid to proper level. Check for oil leaks around filter gasket.
8. Return the bottom dust cover to the original position.

**IMPORTANT :**

- To prevent serious damage or premature failure to the hydraulic system, use only a KUBOTA genuine filter.

### 3. Replacing fuel filter

Consult your local KUBOTA Dealer for this service.

## EVERY 500 HOURS

### 1. Adjusting engine valve clearance

If you do not have the proper tools and/or are not mechanically proficient, consult your local KUBOTA Dealer for this service.

## EVERY AFTER 1000 HOURS

### 1. Cleaning combustion chamber

If you do not have the proper tools and/or are not mechanically proficient, consult your local KUBOTA Dealer for this service.

## EVERY 1000 HOURS OR EVERY 1 YEAR

### 1. Replacing air cleaner primary element and secondary element

(See Cleaning air cleaner primary element on page 60.)

**IMPORTANT :**

- To prevent serious damage to the engine, use only a KUBOTA genuine filter.

**How to remove the secondary element**

1. While turning slightly, pull out the secondary element.

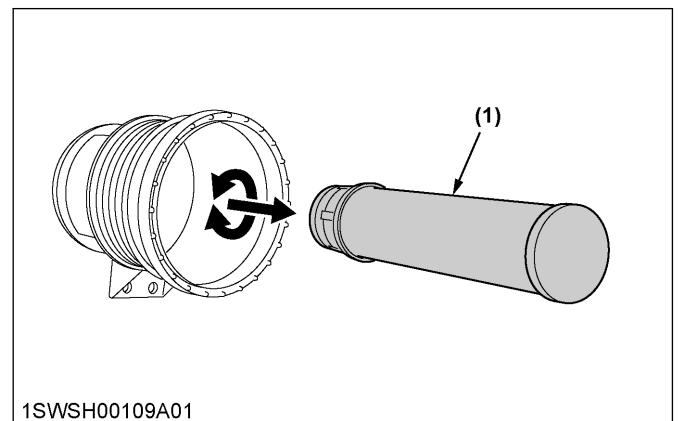

(1) Secondary element

## EVERY 1 YEAR

### 1. Checking fuel lines

If you feel you are unable to make the following service correctly and safely, contact your local KUBOTA Dealer. (See Checking the fuel filter on page 63.)

### 2. Checking hydraulic hose

If you feel you are unable to make the following service correctly and safely, contact your local KUBOTA Dealer.

**! WARNING**

To avoid serious injury or death:

- Be sure to stop the engine, remove the key, and relieve pressure before checking and replacing the hydraulic hose.
- Allow the transmission case to cool down sufficiently; oil can be hot and may cause burns.
- Escaping hydraulic fluid under pressure has sufficient force to penetrate the skin causing serious personal injury. Before disconnecting lines, be sure to relieve all pressure. Before applying pressure to the system, make sure all connections are tight and that lines, pipes, and hoses are not damaged.

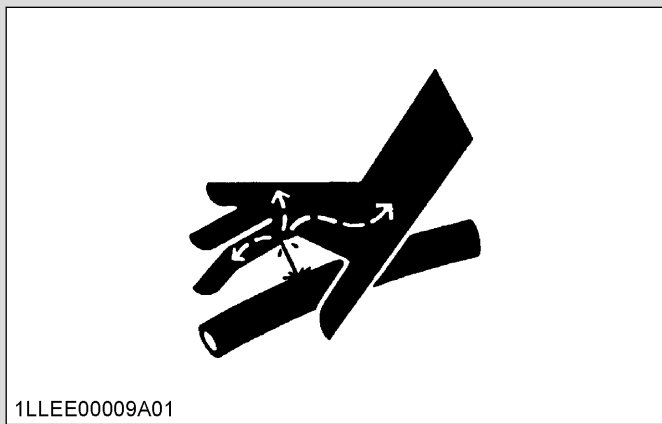

1. Check to see that all lines and hose clamps are tight and not damaged.
2. If hoses and clamps are found worn or damaged, replace or repair them at once.

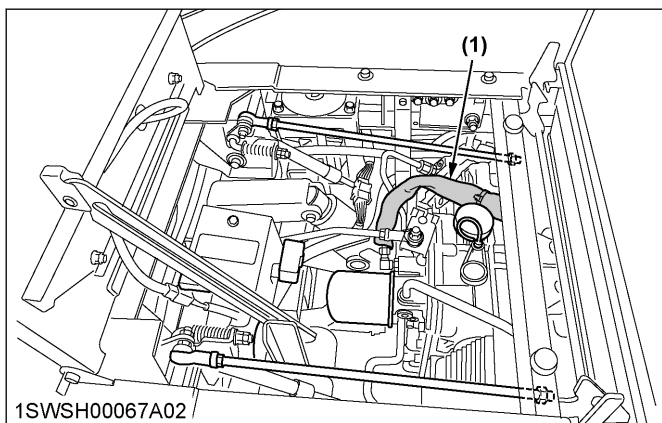

(1) Mower lift cylinder hose

3. Fluid escaping from pinholes may be invisible. Use a piece of cardboard or wood to search for suspected leaks: Do not use hands. Use safety goggles or other eye protection. If injured by escaping fluid, see a medical doctor at once. Serious infection or reaction will result if proper medical treatment is not administered

immediately. This fluid can produce gangrene or severe allergic reaction.

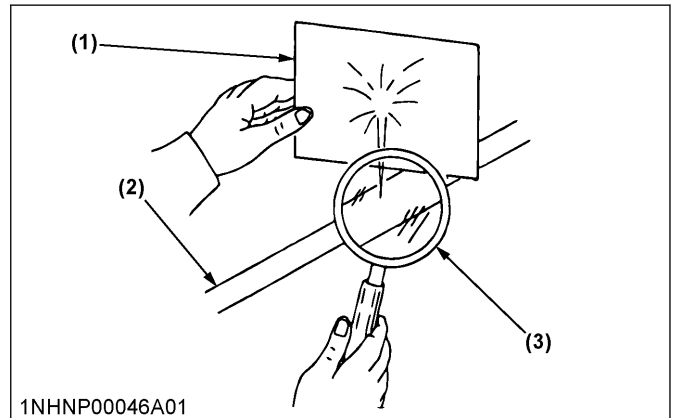

- (1) Cardboard
- (2) Hydraulic line
- (3) Magnifying glass

### 3. Checking intake air line

If you feel you are unable to make the following service correctly and safely, contact your local KUBOTA Dealer.

1. Check to see that hoses and hose clamps are tight and not damaged.
2. If hoses and clamps are found worn or damaged, replace or repair them at once.

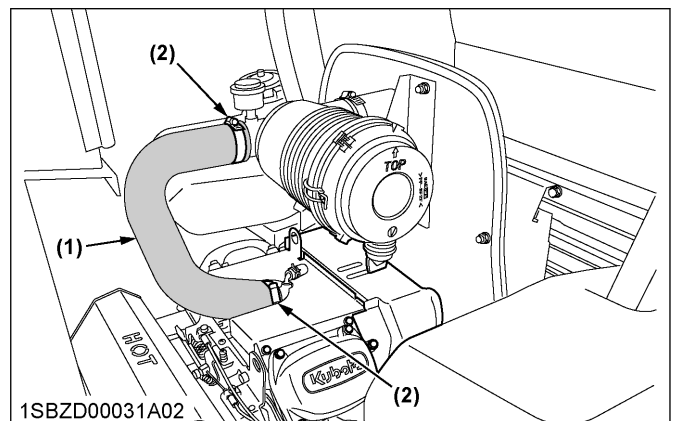

- (1) Hose
- (2) Clamp

### 4. Checking engine breather hose

Consult your local KUBOTA Dealer for this service.

### 5. Checking mower gear box oil seal

Consult your local KUBOTA Dealer for this service.

## EVERY 2 YEARS

### 1. Replacing one way valve

Consult your local KUBOTA Dealer for this service.

## EVERY 4 YEARS

### 1. Replacing hydraulic hoses

Consult your local KUBOTA Dealer for this service.

### 2. Replacing fuel lines

Consult your local KUBOTA Dealer for this service.

### 3. Replacing engine breather hose

Consult your local KUBOTA Dealer for this service.

### 4. Replacing mower gear box oil seal

Consult your local KUBOTA Dealer for this service.

### 5. Replacing intake air line

If you feel you are unable to make the following service correctly and safely, contact your local KUBOTA Dealer. (See Checking intake air line on page 74.)

## SERVICE AS REQUIRED

### 1. Replacing fuses

See the following table of protected circuit and troubleshooting, and find causes of electrical troubles. Replace the blown fuse.

1. Raise the operator's seat.
2. Remove the blown fuse.
3. Place a new fuse of the same capacity in position.

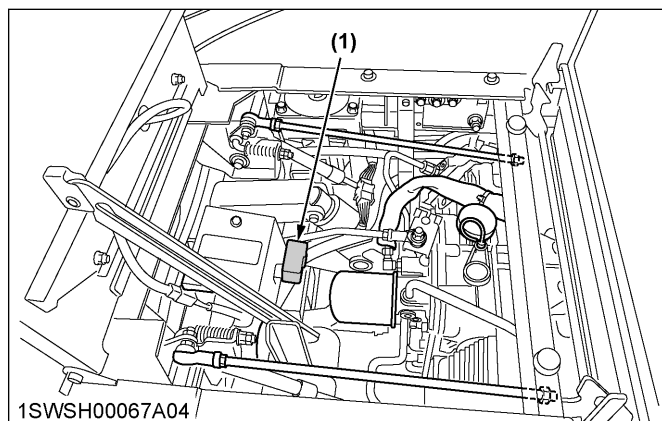

(1) Fuse location

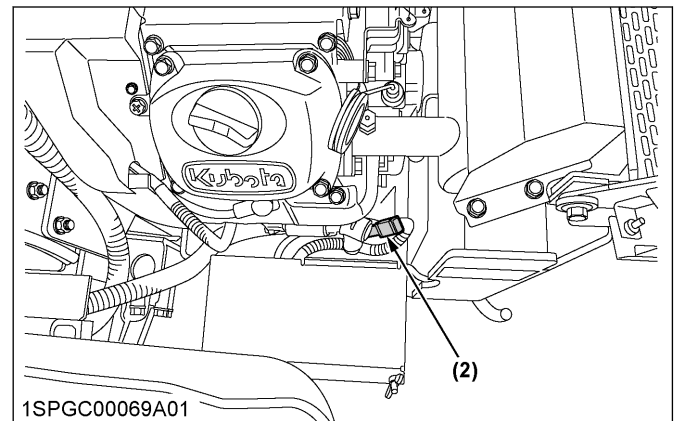

(2) Slow blow fuse

#### IMPORTANT :

- If the new fuse happens to blow out within a short time, contact your dealer for inspection and repair. Never "jump" the fuse with wire or foil, nor install a larger capacity fuse than is recommended.

#### Protected circuit

Fuse no.	Capacity (A)	Protected circuit
(1)	15	Main system
	15	Aux. outlet
	10	OPC control
	20	(Work light)*1
	—	—
(2)	Slow blow fuse 50	Check circuit against wrong battery connection

\*1 Option: The fuse should be in only when the work light is attached.

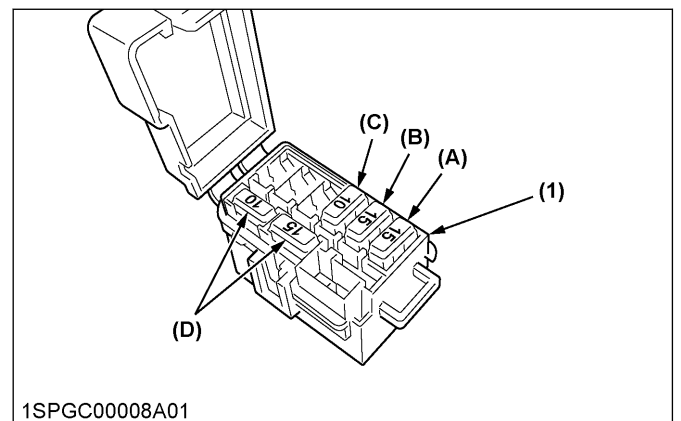

- (A) Main system
- (B) Aux. outlet
- (C) OPC control
- (D) Spare

## 2. Checking and replacing blades

### WARNING

To avoid serious injury or death:

- Be sure to stop the engine and remove the key.
- Blades may be sharp. When you handle blades, wear heavy gloves or wrap the end of the blades with a rag.

### NOTE :

- Before checking or replacing the blade, wipe grass and mud off the top and inside of the mower.
- Especially clean up the inside of the belt cover, because otherwise the belt life will be reduced.

### Checking the blade

The blade cutting edges should be kept sharp at all times.

1. Sharpen the cutting edges if they look like the blade (B).
2. Replace the blades if they look like the blade (C).

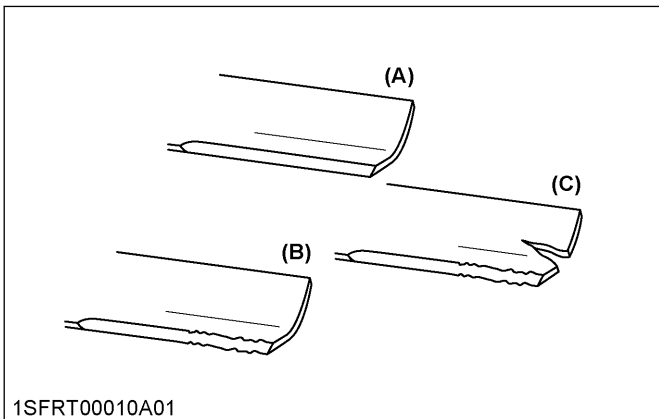

1SFRT00010A01

- (A) New blade
- (B) Worn blade
- (C) Cracked blade

### Replacing

1. Dismount the mower deck from the machine.  
(See DISMOUNTING THE MOWER DECK on page 22.)  
Then turn it over to expose the blades.

### 2. RCK60P

To prevent the spindle from rotating while removing the blade bolts, perform one of the following methods:

- Wedge a block of wood between the blade and mower housing.
- Use a box wrench over the pulley nut.  
Then, loosen the blade bolt as illustrated.

### IMPORTANT :

- Use the proper metric size box or socket wrench to tighten or loosen the blade mounting bolt.

### RCK60P

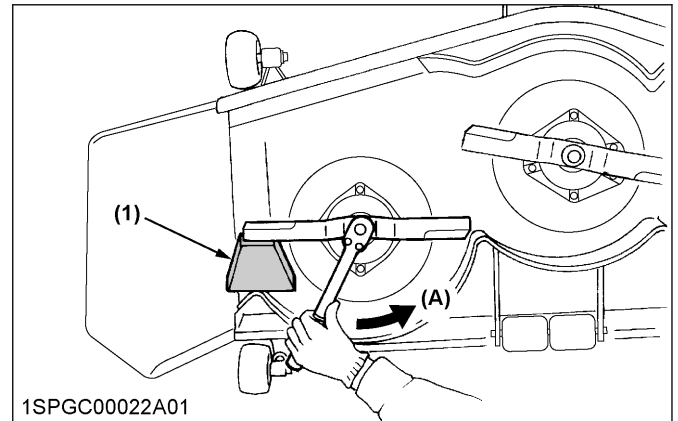

1SPGC00022A01

- (1) Block
- (A) "LOOSEN"

1. To sharpen the blades yourself, clamp the blade securely in a vise.  
Use a large mill file and file along the original bevel until sharp.
2. To check the blade for balance, place a small rod through the center hole. If the blade is not balanced, file the heavy side of the blade until balance is achieved.
3. Pass the spline boss through the blade and 2 cup washers, and tighten the bolt.

### NOTE :

- Make sure that the cup washer is not flattened out or worn; this will cause blade to slip excessively.  
Replace the 2 cup washers if either is damaged.

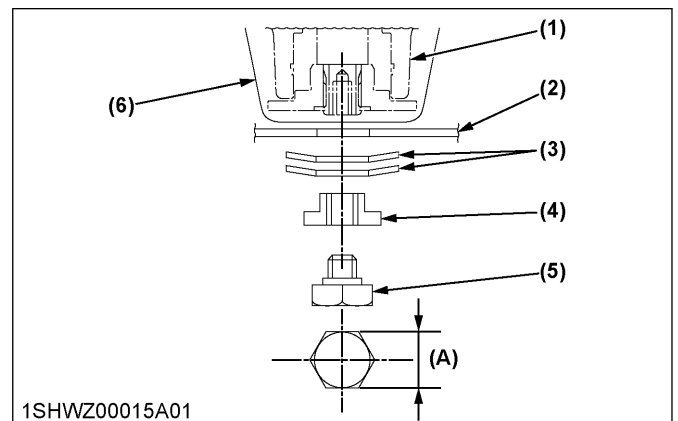

1SHWZ00015A01

- (1) Spindle holder
- (2) Blade
- (3) 2-Cup washers
- (4) Lock washer
- (5) Bolt
- (6) Spindle guard
- (A) 30 mm (1 to 3/16 in.)

### IMPORTANT :

- Tighten the 3 blade bolts to 103 to 118 N·m (10.5 to 12.0 kgf·m, 76.0 to 87.0 lbf·ft) of torque.

- The blade bolts have right hand threads. Turn them counterclockwise to loosen.
- To prolong the service life of the blades, reposition them as shown in the following figure periodically.

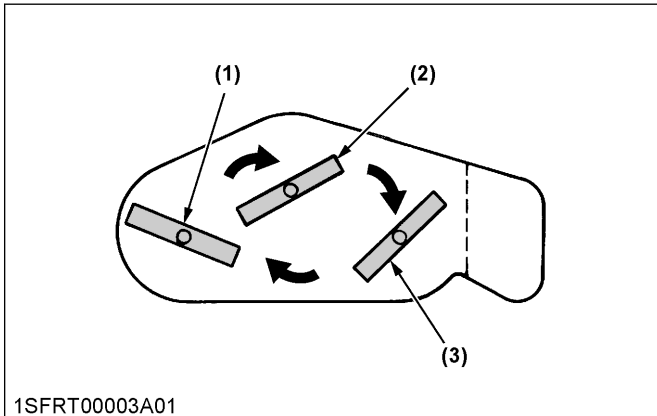

- (1) LH blade  
 (2) Center blade  
 (3) RH blade

### 3. Replacing the mower belt

1. Remove the mower deck from the machine.  
(See DISMOUNTING THE MOWER DECK on page 22.)
2. Remove the left and right hand shield from the mower deck.
3. Clean around the gear box.
4. Remove the belt from the tension pulley.
5. Remove the right hand bracket which mounts the gear box to the mower deck and slip the belt over the top of the gear box.
6. To install a new belt, reverse the previous procedure.

#### NOTE :

- Tighten bracket bolts securely 77.6 to 90.2 N·m (8.0 to 9.2 kgf·m, 57.1 to 66.5 lbf·ft).

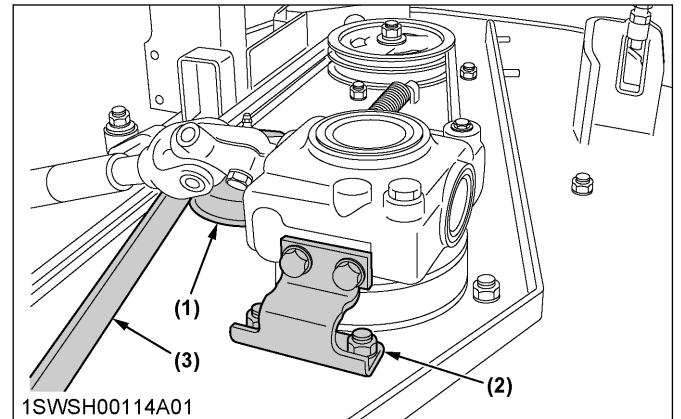

- (1) Tension pulley  
 (2) Bracket (RH)  
 (3) Belt

### 4. Bleeding fuel system

Air must be removed:

1. When the fuel filter or lines are removed.
2. When tank is completely empty.
3. After the machine has not been used for a long period of time.

#### Bleeding procedure is as follows:

1. Fill the fuel tank with fuel.
2. Turn the key switch to the "ON" position and hold it for about 10 seconds.
3. Start the engine and run for about 30 seconds, and then stop the engine.



# ADJUSTMENT

## MOTION CONTROL LEVER

### WARNING

To avoid serious injury or death:

- Park the machine on a firm and level surface.
- If it is necessary to run the engine indoors, use a gas tight exhaust pipe extension to remove the fumes.
- Always try to work in a well-ventilated area.
- Lift up and secure with jack stands or by blocking the rear of the machine. Do not run the machine while adjusting. Remove the rear wheels.
- Do not make only one of the following adjustments (except "MOTION CONTROL LEVER ALIGNMENT"). They are interlinked.
- If you feel you are unable to make the following adjustments correctly and safely, contact your local KUBOTA Dealer.

Details regarding motion control lever alignment can be found in a different section.  
(See Motion control lever alignment on page 79.)

### IMPORTANT :

- Right and left motion control levers can be adjusted independently.

## 1. HST neutral

### WARNING

To avoid serious injury or death:

- Do not operate the machine with a jumper wire.
- If you feel you are unable to make the following adjustments correctly and safely, contact your local KUBOTA Dealer.

1. Lift up and secure with jack stands or by blocking the rear of the machine frame.
2. Remove both rear wheels.
3. Set the engine speed to maximum.
4. Place the motion control lever in the "NEUTRAL LOCK" position.
5. If the rear axle is still turning, follow following steps to adjust the neutral position.
6. Pull the latch lever and raise the operator's seat.

7. Remove the connector from the seat safety switch, then temporarily install a jumper wire across the terminals in the connector of the wire harness.
8. Loosen the lock nut of the motion control rod. Adjust the motion control rod until the rear axle rotation stops.

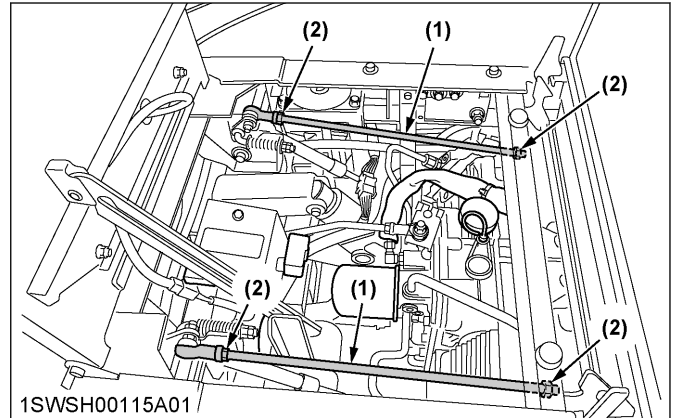

- (1) Motion control rod  
(2) Lock nut

9. Lengthen the rod by 1/2 turn and then tighten the lock nut. Place the motion control lever to the reverse position, and move them to the forward slowly.
10. Place the lever in the "NEUTRAL LOCK" position, and check that the rear axle does not rotate. If the axle does not stopped rotating, adjust the "HST NEUTRAL" again.
11. Adjust the other side "HST NEUTRAL" equally.
12. After adjustment, make sure to stop the engine immediately.

## 2. Motion control lever neutral position

1. Lift-up and secure with jack stands or blocking the rear of the machine frame.
2. Remove both rear wheels.
3. Start the engine, and run at maximum speed.
4. Pull the lever to the reverse maximum position and release the lever.
5. Measure the axle rotation.
6. Loosen the lock nut and adjust the speed control bolt length so that the axle rotation would stop.
7. Tighten the lock nut.
8. Check the axle rpm again. If it is not correct, adjust again.

9. Adjust the other side equally.
10. After adjustment, make sure to stop the engine immediately.

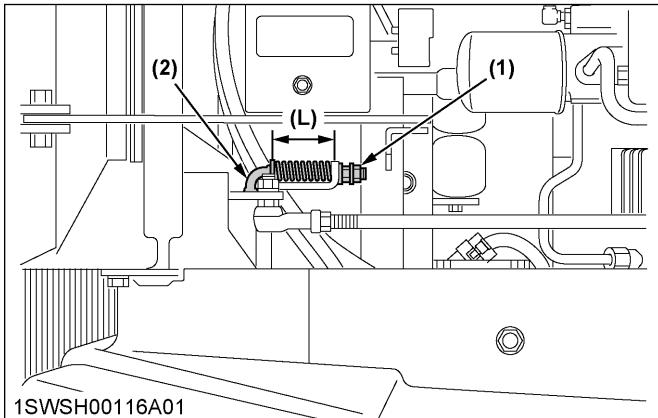

(1) Lock nut  
(2) Speed control bolt  
(L) 50 mm (2.0 in.)

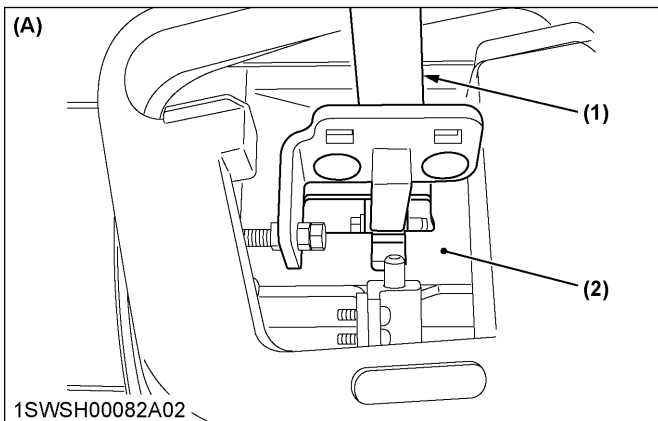

(1) Motion control lever  
(2) Guide plate  
(A) "NEUTRAL" position (hands off)

### 3. Maximum speed (forward)

Consult your local KUBOTA Dealer for this service.

### 4. Motion control lever alignment

**⚠ WARNING**  
**To avoid serious injury or death:**

- Park the machine on a firm and level surface.
- Stop the engine, remove the key and apply the parking brake.

#### 4.1 Checking the alignment

1. Check the gap and space between the levers at the maximum forward position.

Recommendation	Gap: 0 to 2 mm (0 to 0.08 in.) Space: 10 to 20 mm (0.4 to 0.8 in.)
----------------	---

If the positions of the motion control levers are unequal, adjustment is necessary.

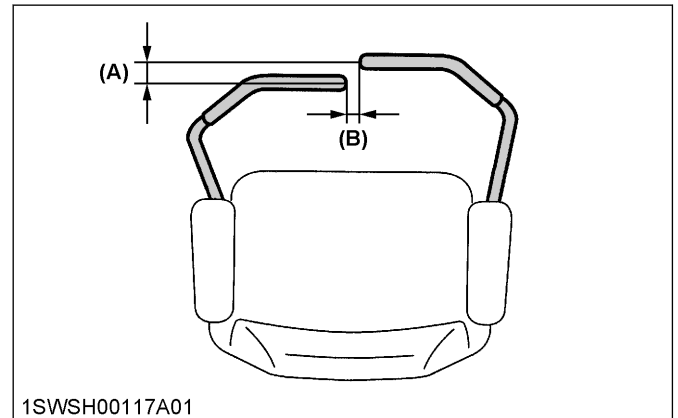

(A) "GAP"  
(B) "SPACE"

#### 4.2 Aligning the motion control levers

1. Stop the engine and apply the parking brake.
2. Loosen the screws and remove the lever guide.

##### Lever position (high or low)

1. Remove the nut and select the motion control lever position, high or low.
2. Tighten the nut.

In this figure, the motion control lever is set at the low position.

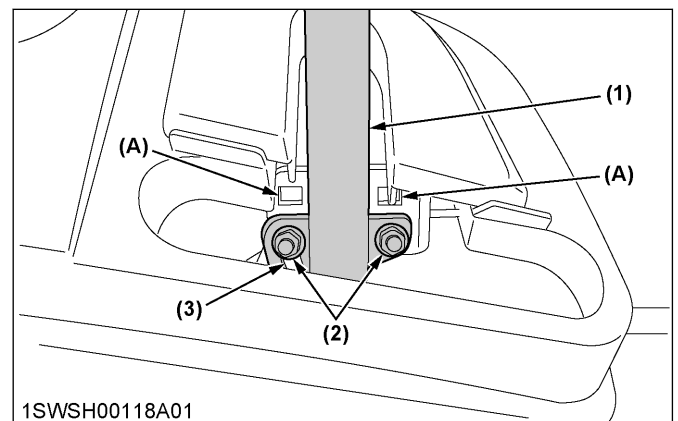

(1) Motion control lever  
(2) Nut  
(3) Tab slot  
(A) High position

##### Lever alignment (right and left)

1. Loosen the nut.
2. Slide both levers forward or rearward to the desired position within tab slots until the levers are aligned.
3. Tighten the nut.
4. Install the lever guide with the screws and tighten them securely.

##### NOTE :

- If the ends of the levers strike against each other while in the "NEUTRAL" position, move

the levers outward to the **“NEUTRAL LOCK”** position and carefully bend them outward. Move them back to the **“NEUTRAL”** position and check for the recommended space.

## MOWER DECK LEVEL

### 1. Anti-scalp rollers

#### WARNING

To avoid serious injury or death:

- Park the machine on a firm and level surface.
- Apply the parking brake.
- Stop the engine and remove the key.
- Wait for all moving parts to stop.

#### NOTE :

- The flattest cut can be achieved by having the anti-scalp rollers adjusted off the ground. Check the anti-scalp roller adjustments each time the mower deck cutting height is changed. It is recommended that all the anti-scalp rollers be kept off the ground to minimize scuffing.

1. Check the machine tire pressure. Inflate tires to the correct pressure. (See TIRES AND WHEELS on page 42.)
2. Start the engine.
3. Raise up the mower deck to the top position. (Also the top end of the lift.)
4. Turn the cutting height control dial to adjust the height.
5. Lower the mower deck.

#### a. Front side anti-scalp roller

Adjust height of the front side anti-scalp roller by replacing the collar (collar is raised and lowered) or shifting the pin to approximately 19 mm (0.75 in.) between rollers and ground. Adjust both side rollers to the same height.

#### RCK60P

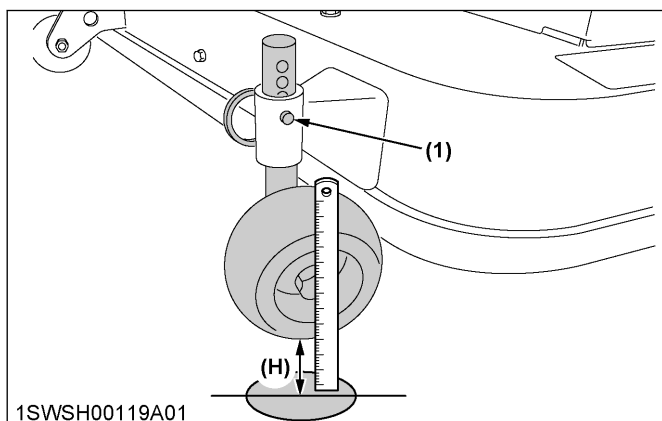

(1) Pin (H) 19 mm (0.75 in.)

#### b. Rear side anti-scalp roller

Adjust height of the rear side anti-scalp roller by shifting the bolt to approximately 19 mm (0.75 in.) between rollers and ground. Adjust both side rollers to the same height.

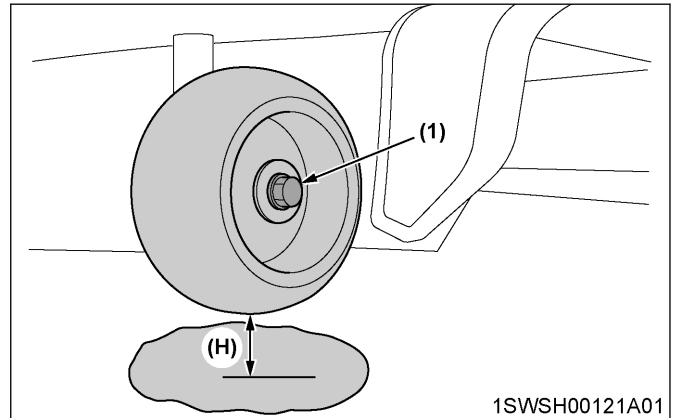

(1) Bolt (H) 19 mm (0.75 in.)

### 2. Leveling the mower deck (side-to-side)

#### WARNING

To avoid serious injury or death:

- Park the machine on a firm and level surface.
- Apply the parking brake.
- Disengage the PTO (OFF).
- Stop the engine, remove the key and remove the mower universal joint while checking or adjusting the level of the mower deck.

#### IMPORTANT :

- Check the machine tire pressure. Inflate the tires to the correct pressure. (See TIRES AND WHEELS on page 42.)

#### Checking the level (side-to-side)

#### NOTE :

- The mower deck anti-scalp rollers should not contact the ground.
1. Raise the mower deck to the top position. (Also the top end).
  2. Turn the cutting height set dial to the 3 in. cutting height position.
  3. Lower the mower deck.
  4. Position the right mower blade in the side-to-side position.
  5. Measure from outside the blade tip to the level surface with a short ruler or leveling gauge.

#### Reference

Height of the blade at the flat surface	76 mm (3 in.)
---	---------------

**NOTE :**

- There is a difference of blade height between flat surface and ground measurements.

6. Check that the left side blade has the same height. The difference between both measurements is less than 3 mm (0.125 in.).
7. If the side-to-side adjustment is not within the given tolerance, adjustment is necessary.

Side-to-side adjustment	Less than 3 mm (0.125 in.)
-------------------------	-------------------------------

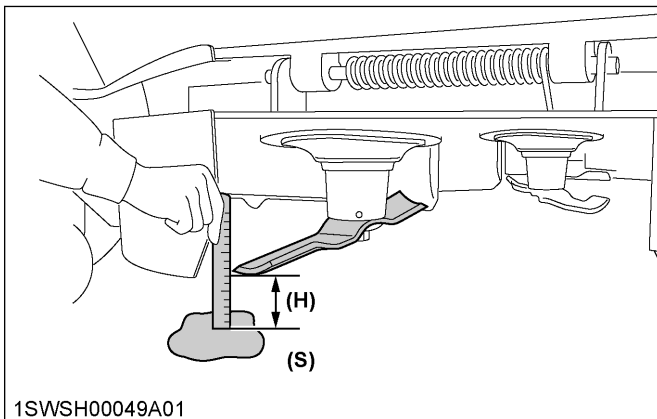
**RCK60P**

1SWSH00049A01

(S) Side  
(H) Height

**Adjusting the level (side-to-side)**

1. Raise up the mower deck to the top position. (Also the top end).
2. Turn the cutting height set dial to the 3 in. cutting height position.
3. Place 51 mm (2 in.) high wood blocks under each side of the mower deck.  
Anti-scalp rollers must not rest on the wood block.
4. Lower the mower deck.
5. Position the mower blade in the side-to-side position.
6. Loosen the lock nuts of the right side of the machine.
7. Adjust the cutting height fine tuning bolts to set 76 mm (3 in.) blade height.  
Front and rear side bolts must be adjusted.
8. Lock the nuts.
9. Adjust the left side equally.
10. Check the side-to-side level. If it is not level, adjustment is necessary.

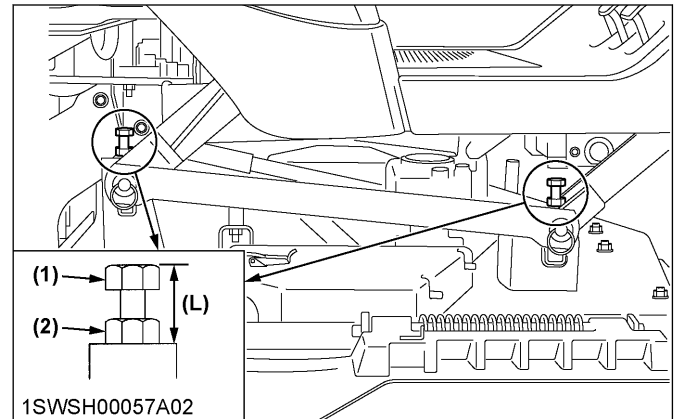

1SWSH00057A02

(1) Cutting height fine tuning bolt  
(2) Lock nut  
(L) Length

**3. Leveling the mower deck (front-to-rear)****⚠ WARNING**

To avoid serious injury or death:

- Park the machine on a firm and level surface.
- Engage the parking brake.
- Disengage the PTO.
- Stop the engine, remove the key and remove the mower universal joint while checking or adjusting the level of the mower deck.

**IMPORTANT :**

- Check the machine tire pressure.  
Inflate the tires to the correct pressure.  
(See **TIRES AND WHEELS** on page 42.)

**Checking level (front-to-rear)****NOTE :**

- The mower deck anti-scalp rollers should not contact the ground.
1. Raise the mower deck to the top position. (Also the top end).
  2. Turn the cutting height set dial to the 3 in. cutting height position.
  3. Lower the mower deck.
  4. Position the right mower blade in the front-to-rear position.
  5. Measure from the right front blade tip to the level surface with a short ruler or leveling gauge.
  6. Turn the blade 180° and measure from the right rear blade tip to the level surface.
  7. Check that the left side blade has the same dimensions. The difference between both measurements should be less than 6 mm (0.25 in.). The front side must be lower than the rear side.
  8. If the front-to-rear adjustment is not within the given tolerance, adjustment is necessary.

RCK60P

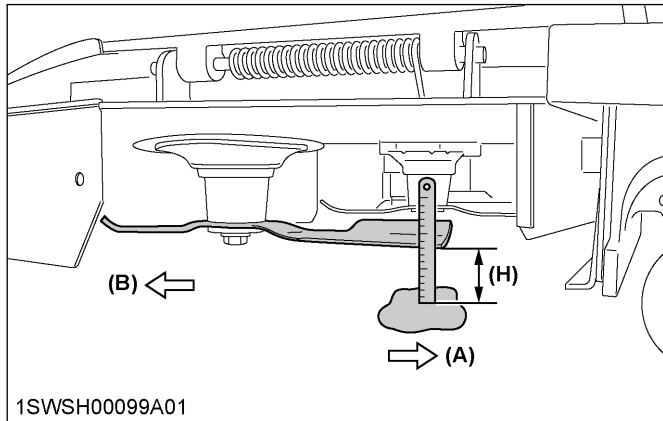

(A) Front (H) Height  
 (B) Rear

Front-to-rear adjustment	Less than 6 mm (0.25 in.) front side must be lower than rear side.
--------------------------	--

**Adjusting the level (front-to-rear)**

1. Raise up the mower deck to the top position. (Also the top end).
2. Turn the cutting height set dial to the 3 in. cutting height position.
3. Place 51 mm (2 in.) height wood blocks under each side of the mower deck.  
Anti-scalp rollers must not rest on the wood block.
4. Lower the mower deck.
5. Loosen the lock nuts of the front side of the machine.
6. Adjust the cutting height fine tuning bolts to set 76 mm (3 in.) blade height.  
Both front side bolts must be adjusted.
7. Lock the nuts.
8. Adjust the other side equally.



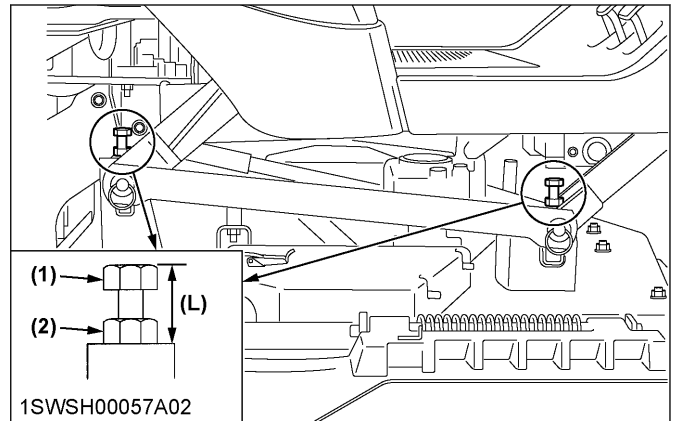

**IMPORTANT :**

- **The difference between both measurements should be less than 6 mm (0.25 in.). The front side must be lower than the rear side.**
9. Check the front-to-rear level. If it is not level, adjustment is necessary.



(1) Cutting height fine tuning bolt (L) Length  
 (2) Lock nut

## GENERAL TORQUE SPECIFICATION

American standard cap screws with UNC or UNF threads				Metric cap screws			
SAE grade no.		GR.5 	GR.8 	Property class	Class 8.8 	Class 10.9 	
1/4	(lbf · ft) (N · m) (kgf · m)	8-9.6 10.7-12.9 1.11-1.33	12-14.4 16.1-19.3 1.66-1.99	M6	(lbf · ft) (N · m) (kgf · m)	7.2-8.3 9.81-11.3 1.0-1.15	
5/16	(lbf · ft) (N · m) (kgf · m)	17-20.5 23.1-27.8 2.35-2.84	24-29 32.5-39.3 3.31-4.01	M8	(lbf · ft) (N · m) (kgf · m)	17.4-20.2 23.6-27.4 2.4-2.8	21.7-25.3 29.4-34.3 3.0-3.5
3/8	(lbf · ft) (N · m) (kgf · m)	35-42 47.5-57.0 4.84-5.82	45-54 61.0-73.2 6.22-7.47	M10	(lbf · ft) (N · m) (kgf · m)	35.5-41.2 48.1-55.8 4.9-5.7	44.9-52.1 60.8-70.5 6.2-7.2
1/2	(lbf · ft) (N · m) (kgf · m)	80-96 108.5-130.2 11.07-13.29	110-132 149.2-179.0 15.22-18.27	M12	(lbf · ft) (N · m) (kgf · m)	57.2-66.5 77.5-90.1 7.9-9.2	76.0-86.8 103-117 10.5-12.0
9/16	(lbf · ft) (N · m) (kgf · m)	110-132 149.2-179.0 15.22-18.27	160-192 217.0-260.4 22.14-26.57	M14	(lbf · ft) (N · m) (kgf · m)	91.2-108 124-147 12.6-15.0	123-144 167-196 17.0-20.0
5/8	(lbf · ft) (N · m) (kgf · m)	150-180 203.4-244.1 20.75-24.91	220-264 298.3-358.0 30.44-36.53	M16	(lbf · ft) (N · m) (kgf · m)	145-166 196-225 20.0-23.0	192-224 260-303 26.5-31.0

# TIGHTENING TORQUE CHART

Thread size d (mm)	Hex. bolt head size B (mm)	No mark			7T		
		lbf·ft	N·m	kgf·m	lbf·ft	N·m	kgf·m
M8	12 or 13	13.0-15.2 (14.1 ± 1.1)	17.8-20.6 (19.2 ± 1.4)	1.9-2.1 (2.0 ± 0.1)	17.5-20.3 (18.9 ± 1.4)	23.5-27.5 (25.5 ± 2.0)	2.4-2.8 (2.6 ± 0.2)
M10	14 or 17	28.9-33.3 (31.1 ± 2.2)	39.3-45.1 (42.2 ± 2.9)	4.0-4.6 (4.3 ± 0.3)	35.4-41.2 (38.3 ± 2.9)	48.1-55.9 (52.0 ± 3.9)	4.9-5.7 (5.3 ± 0.4)
M12	17 or 19	46.3-53.5 (49.9 ± 3.6)	62.8-72.6 (67.7 ± 4.9)	6.4-7.4 (6.9 ± 0.5)	57.1-66.5 (61.8 ± 4.7)	77.6-90.2 (83.9 ± 6.3)	8.0-9.2 (8.6 ± 0.6)
M14	19 or 22	79.6-92.6 (86.1 ± 6.5)	107.9-125.5 (116.7 ± 8.8)	11.0-12.8 (11.9 ± 0.9)	91.1-108.5 (99.8 ± 8.7)	123.6-147.0 (135.3 ± 11.7)	12.6-15.0 (13.8 ± 1.2)

**NOTE :**

- Figure [7] on the top of the bolt indicates that the bolt is made of special material.
- Before tightening, check the figure on top of the bolt.

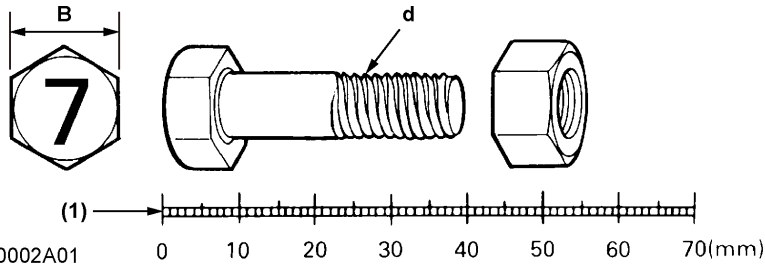

(1) Scale

# STORAGE

## WARNING

To avoid serious injury or death:

- Do not clean the machine with the engine running.
- To avoid the danger of exhaust fume poisoning, do not operate the engine in a closed building without proper ventilation.
- When storing, remove the key to avoid unauthorized persons from operating the machine and getting injured.

## STORING THE MACHINE

If you intend to store your machine for an extended period of time, follow the procedures outlined below. These procedures will insure that the machine is ready to operate with minimum preparation when it is removed from storage,

1. Check for loose bolts and nuts, and tighten if necessary.
2. Apply grease to machine areas where bare metal will rust also to pivot areas.
3. Inflate the tires to a pressure a little higher than usual.
4. Change the engine oil and run the engine to circulate oil throughout the engine block and internal moving parts for about 5 minutes.
5. With all implements lowered to the ground, coat any exposed hydraulic cylinder piston rods with grease.
6. Remove the battery from the machine. When disconnecting the cables from the battery, start with the negative terminal first. When connecting the cables to the battery, start with the positive terminal first.
7. Keep the machine in a dry place where the machine is sheltered from rain. Cover the machine.
8. Store the machine indoors in a dry area that is protected from sunlight and excessive heat. If the machine must be stored outdoors, cover it with a waterproof tarpaulin.
9. Jack the machine up and place blocks under the front and rear axles so that all 4 tires are off the ground. Keep the tires out of direct sunlight and extreme heat.

### IMPORTANT :

- When washing the machine, be sure to stop the engine. Allow sufficient time for the engine to cool before washing.

- Cover the machine after the muffler and the engine have cooled down.

## REMOVING THE MACHINE FROM STORAGE

1. Check the tire air pressure and inflate the tires if they are low.
2. Jack the machine up and remove the support blocks.
3. Install the battery. Before installing the battery, make sure it is fully charged.
4. Check all fluid levels (engine oil, transmission/hydraulic oil, engine coolant and any attached implements).
5. Check all hydraulic and fuel hoses for cracks, hardening, bubbles and leaks.
6. Check all control levers and the brake for proper function, repair or lubricate as necessary.
7. Start the engine. Observe all gauges. If all gauges are functioning properly and reading normal, move the machine outside.
8. Once outside, park the machine securely set the parking brake, place the control levers in the neutral lock position and let the engine idle for at least 5 minutes.
9. Shut the engine off and walk around machine and make a visual inspection looking for evidence of oil or water leaks.
10. With the engine fully warmed up, release the parking brake and test the brakes for proper adjustment as you move forward. Adjust the brakes as necessary.

## 1. Fuel

### WARNING

To avoid serious injury or death:

- Make sure the engine and muffler are sufficiently cooled down before trying to drain the fuel; otherwise there is a danger of causing a fire.

### IMPORTANT :

- Do not leave the fuel (gasoline) in the fuel tank or carburetor for more than a month; otherwise the fuel might deteriorate to make it difficult to



start the engine or cause the malfunction of the engine.

**NOTE :**

- If the engine is not to be used for more than a month, drain the fuel from the carburetor and use up all fuel in the tank.

Before the off-season, drain the fuel from the carburetor and fuel filter bowl in the following manner.

**Draining the carburetor**

1. Put an oil receiving pan under the drain port.
2. Turn the carburetor fuel valve to the "DRAIN" position to drain the fuel from the carburetor.
3. Drain the gasoline from the fuel filter bowl. Clean the inside of the fuel filter bowl as necessary.
4. Reinstall the fuel filter bowl.
5. After that, turn the carburetor fuel valve to the [STOP] (CLOSE) position.

**NOTE :**

- Before adding fuel, make sure the carburetor fuel valve is in the [STOP] (CLOSE) position and that the drain plug is securely tightened. Turn the carburetor fuel valve to the [RUN] (OPEN) position before starting the engine.

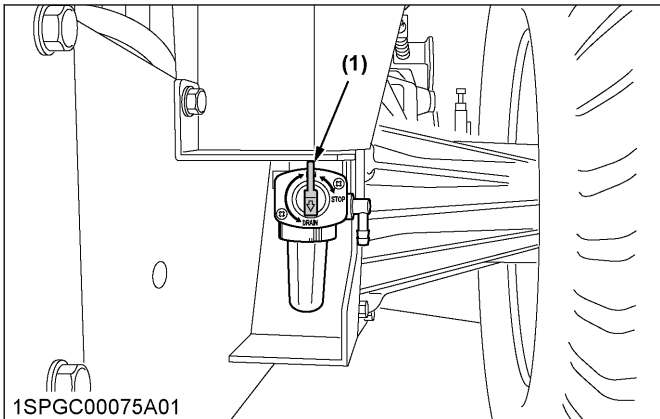

1SPGC00075A01

(1) Carburetor fuel valve

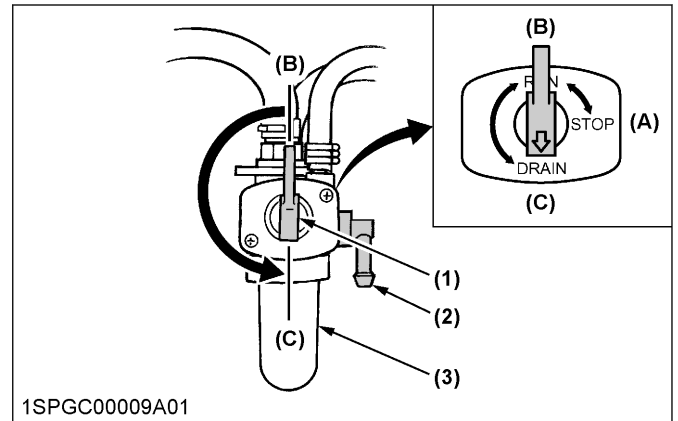

1SPGC00009A01

(1) Carburetor fuel valve (A) [STOP] (CLOSE)  
 (2) Drain port (B) [RUN] (OPEN)  
 (3) Fuel filter bowl (C) [DRAIN]

**2. Inspecting and cleaning fuel filter bowl**

Clean the fuel filter bowl before adding fuel to the engine.

**WARNING**

To avoid serious injury or death:

- Never smoke nor use fire or naked flame during inspection or cleaning.

**IMPORTANT :**

- Mixing of foreign matter or water in the fuel might cause a plugged filter element prematurely or cause much water to accumulate on the bottom of the fuel filter bowl.
- If water accumulates on the bottom of the fuel filter bowl, clean the fuel filter bowl or replace it with a new one.

**Inspecting and cleaning**

1. Turn the carburetor fuel valve from the [RUN] (OPEN) position to the [STOP] (CLOSE) position.

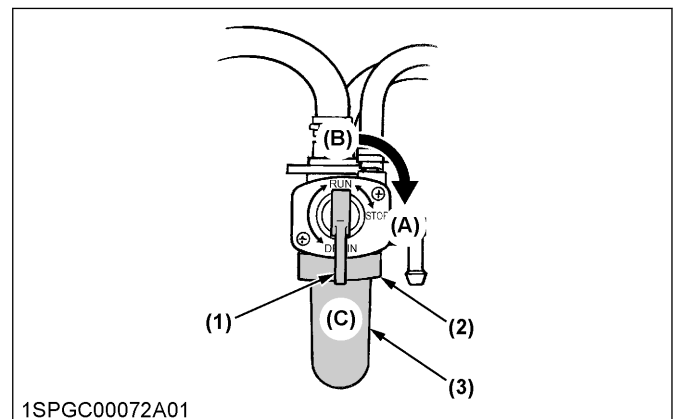

1SPGC00072A01

(1) Carburetor fuel valve (A) [STOP] (CLOSE)  
 (2) Drain port (B) [RUN] (OPEN)  
 (3) Fuel filter bowl (C) [DRAIN]

2. Loosen the ring screw and remove the fuel filter bowl.
3. Remove the filter element and wash it lightly by dipping in gasoline. Replace any excessively contaminated element with a new one.

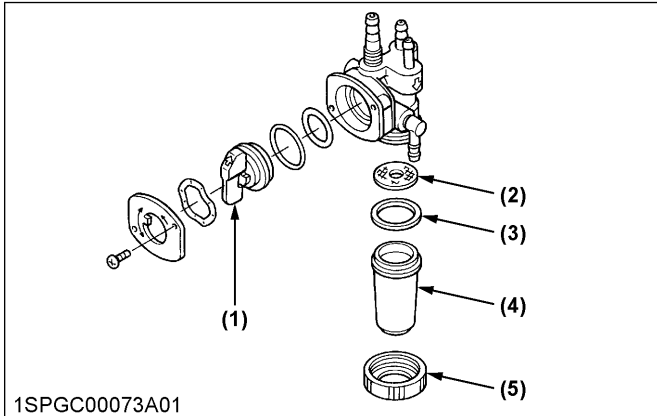

- (1) Carburetor fuel valve  
 (2) Element  
 (3) Packing  
 (4) Fuel filter bowl  
 (5) Ring screw

**IMPORTANT :**

- Use caution not to damage or lose the element or packing.
  - Replace any element that shows an excessive plugging with a new one.
4. Reinstall the packing and element, using caution not to contaminate them.

**IMPORTANT :**

- Mixing of dirt or foreign matter in the fuel might cause the malfunction of the engine.

# TROUBLESHOOTING

## ENGINE TROUBLESHOOTING

If something is wrong with the engine, refer to the following table for the cause and its corrective measure.

Symptom (if)	Cause	Remedy	
The engine is difficult to start or will not start.	• No operator on the seat.	• Sit on the operator's seat.	
	• Parking brake pedal not in the proper position.	• Apply the parking brake.	
	• PTO lever not in the proper position.	• Make sure PTO lever is in "DISENGAGED" (OFF) position.	
	• Motion control levers not in the proper position.	• Make sure motion control levers are in "NEUTRAL LOCK" position.	
	• Key switch is not in the proper position.	• Make sure key switch is in "ON" position.	
	• Carburetor fuel drain valve in the [STOP] (CLOSE) position.	• Open carburetor fuel drain valve. [RUN] (OPEN) position.	
	• No fuel.	• Replenish fuel.	
	• Improper or stale fuel. (Fuel quality is poor.)	• Replace fuel and the fuel filter.	
	• Water or dirt in the fuel system.	• Replace fuel and consult your KUBOTA Dealer.	
	• Fuel hose or fuel filter clogged or damaged.	• Clean or replace fuel lines, and consult your KUBOTA Dealer.	
	• Air cleaner is clogged.	• Clean or replace the air cleaner.	
	• Spark plug damaged.		• Adjust the spark plug gap or replace the spark plug.
			• Check the spark plug wire connection.
	• Fuse is blown.	• Replace the fuse.	
	• Engine oil viscosity is wrong.	• Use oils of different viscosities, depending on ambient temperature.	
• The battery becomes weak and the engine does not turn over quick enough.		• Clean battery cables and terminals.	
		• Charge the battery.	
		• In cold weather, always remove the battery from the engine, charge and store it indoors. Install it on the machine only when the machine is going to be used.	
• Over choking or choke is adjusted incorrectly.	• Check and consult your KUBOTA Dealer.		
Insufficient engine power.	• Insufficient or dirty fuel.	• Check the fuel system.	
	• Fuel filter is clogged.	• Replace the fuel filter.	
	• Air cleaner clogged.	• Clean or replace the air cleaner.	
	• Spark plug damaged.	• Adjust the spark plug gap or replace it.	

(Continued)

<b>Symptom (if)</b>		<b>Cause</b>	<b>Remedy</b>
The engine stops suddenly.		<ul style="list-style-type: none"> <li>• Insufficient fuel.</li> </ul>	<ul style="list-style-type: none"> <li>• Check the fuel valve position.</li> <li>• Refuel.</li> </ul>
Rough engine running.		<ul style="list-style-type: none"> <li>• Spark plug damaged.</li> </ul>	<ul style="list-style-type: none"> <li>• Adjust the spark plug gap or replace it.</li> </ul>
		<ul style="list-style-type: none"> <li>• High tension cord damaged.</li> </ul>	<ul style="list-style-type: none"> <li>• Consult your KUBOTA Dealer.</li> </ul>
		<ul style="list-style-type: none"> <li>• Carburetion problems.</li> </ul>	<ul style="list-style-type: none"> <li>• Consult your KUBOTA Dealer.</li> </ul>
		<ul style="list-style-type: none"> <li>• Ignition coil damaged.</li> </ul>	<ul style="list-style-type: none"> <li>• Consult your KUBOTA Dealer.</li> </ul>
		<ul style="list-style-type: none"> <li>• Choke is adjusted incorrectly.</li> </ul>	<ul style="list-style-type: none"> <li>• Consult your KUBOTA Dealer.</li> </ul>
		<ul style="list-style-type: none"> <li>• Fuel hose or fuel filter clogged or damaged.</li> </ul>	<ul style="list-style-type: none"> <li>• Clean or replace fuel lines, and consult your KUBOTA Dealer.</li> </ul>
		<ul style="list-style-type: none"> <li>• Improper or stale fuel. (Fuel quality is poor.)</li> </ul>	<ul style="list-style-type: none"> <li>• Replace fuel and the fuel filter.</li> </ul>
Exhaust fumes are colored.		Black, dark or gray <ul style="list-style-type: none"> <li>• Overload.</li> <li>• Low grade fuel is used.</li> <li>• Fuel filter is clogged.</li> <li>• Air cleaner is clogged.</li> <li>• Choke is not fully opened.</li> </ul>	<ul style="list-style-type: none"> <li>• Reduce load.</li> <li>• Use specified fuel.</li> <li>• Replace the fuel filter.</li> <li>• Clean or replace the air cleaner element.</li> <li>• Check the choke knob position.</li> </ul>
		Blue white <ul style="list-style-type: none"> <li>• Excessive engine oil.</li> <li>• Piston ring is worn or stuck.</li> </ul>	<ul style="list-style-type: none"> <li>• Reduce to the specified oil level.</li> <li>• Consult your KUBOTA Dealer.</li> </ul>
Engine overheats.		<ul style="list-style-type: none"> <li>• Engine overloaded.</li> </ul>	<ul style="list-style-type: none"> <li>• Lower speed or reduce load.</li> </ul>
		<ul style="list-style-type: none"> <li>• Engine oil is insufficient.</li> </ul>	<ul style="list-style-type: none"> <li>• Replenish engine oil.</li> </ul>
		<ul style="list-style-type: none"> <li>• Engine air intake screen and cooling fins are dirty.</li> </ul>	<ul style="list-style-type: none"> <li>• Clean the air intake screen and cooling fins.</li> </ul>
		<ul style="list-style-type: none"> <li>• Air cleaner element is plugged.</li> </ul>	<ul style="list-style-type: none"> <li>• Clean or replace the air cleaner element.</li> </ul>
		<ul style="list-style-type: none"> <li>• Engine speed is too low.</li> </ul>	<ul style="list-style-type: none"> <li>• Operate at the "FAST" speed.</li> </ul>
Engine knocks.		<ul style="list-style-type: none"> <li>• Stale or low octane fuel.</li> </ul>	<ul style="list-style-type: none"> <li>• Use specified fuel.</li> </ul>
		<ul style="list-style-type: none"> <li>• Engine overloaded.</li> </ul>	<ul style="list-style-type: none"> <li>• Lower ground speed or reduce load.</li> </ul>
		<ul style="list-style-type: none"> <li>• Engine speed is too low.</li> </ul>	<ul style="list-style-type: none"> <li>• Operate at the "FAST" speed.</li> </ul>
Engine will not idle.		<ul style="list-style-type: none"> <li>• Spark plug damaged.</li> </ul>	<ul style="list-style-type: none"> <li>• Adjust the spark plug gap or replace it.</li> </ul>
		<ul style="list-style-type: none"> <li>• Faulty spark plug.</li> </ul>	<ul style="list-style-type: none"> <li>• Replace the spark plug.</li> </ul>
		<ul style="list-style-type: none"> <li>• Carburetion problem.</li> </ul>	<ul style="list-style-type: none"> <li>• Consult your KUBOTA Dealer.</li> </ul>

If you have any questions, contact your local KUBOTA Dealer.

## BATTERY TROUBLESHOOTING

Symptom (if)	Cause	Remedy	Preventive measure
The starter does not function.	• Battery overuse, dim lights.	• Charge the battery sufficiently.	• Charge the battery properly.
	• The battery has not been recharged.		
	• Poor terminal connection.	• Clean the terminal and tighten securely.	• Keep the terminal clean and tight. Apply grease and treat with anti-corrosives.
	• The battery life has expired.	• Replace the battery.	
The starter does not function from the beginning, and lights soon become dim.	• Insufficient charging.	• Charge the battery sufficiently.	• The battery must be serviced properly before initial use.
When viewed from the top, the top of the plates look whitish.	• The battery was used with an insufficient amount of electrolyte.	• Add distilled water and charge the battery.	• Regularly check the electrolyte level.
	• The battery was used too much without recharging.	• Charge the battery sufficiently.	• Charge the battery properly.
Recharging is impossible.	• The battery life has expired.	• Replace the battery.	
Terminals are severely corroded and heated up.	• Poor terminal connection.	• Clean the terminal and tighten securely.	• Keep the terminal clean and tight. Apply grease and treat with anti-corrosives.
The battery electrolyte level drops rapidly.	• There is a crack or pin holes in the electrolytic cells.	• Replace the battery.	
	• Charging system trouble.	• Contact your local KUBOTA Dealer.	

If you have any questions, contact your local KUBOTA Dealer.

## MACHINE TROUBLESHOOTING

Symptom (if)	Cause	Remedy
The machine operation is not smooth.	• The hydrostatic transmission fluid is insufficient.	• Fill with oil.
	• The filter is clogged.	• Replace the filter.
The machine does not move while the engine is running.	• The parking brake is on.	• Release the parking brake.
	• The transmission fluid level is insufficient.	• Fill with oil.
The machine moves when the motion control levers are in the "NEUTRAL LOCK" position (operating the engine).	• The hydrostatic lever linkage is not correctly adjusted.	• Consult your dealer for hydrostatic lever linkage adjustment or pressure adjustment.
	• The control linkage pivots are sticking.	• Pull up and lubricate linkage.

If you have any questions, contact your local KUBOTA Dealer.

## MOWER TROUBLESHOOTING

Symptom (if)	Cause	Remedy
Blade does not rotate.	• PTO system is not normal: PTO system malfunctioning.	• Consult your KUBOTA Dealer.
	• PTO system is normal: Broken mower belt.	• Replace.
Mower belt slipping.	• Weaken tension spring.	• Replace.
	• Worn mower belt.	• Replace.
	• Mower plugged.	• Unplug and clean mower deck.
	• Debris in pulleys.	• Clean.
Discharge deflector plugged.	• Grass too wet.	• Wait for grass to dry.
	• Grass too long.	• Raise cutting height and cut grass twice.
	• Cutting too low.	• Raise cutting height.
	• Engine rpm too low.	• Mow at full throttle.
	• Ground speed too fast.	• Slow down.
Streaking of grass uncut.	• Ground speed too fast.	• Slow down.
	• Engine rpm too low.	• Mow at full throttle, check and reset engine rpm.
	• Grass too long.	• Cut grass twice.
	• Blades dull or damaged.	• Replace blades or have blades sharpened.
	• Debris in mower deck.	• Clean mower deck.
Uneven cut.	• Mower deck not level.	• Level the mower deck.
	• Ground speed too fast.	• Slow down.
	• Blades dull.	• Have blades sharpened.
	• Blades worn or damaged.	• Replace the blades.
	• Low tire inflation.	• Add air to correct pressure.
	• Anti-scalp rollers not adjusted correctly.	• Adjust the anti-scalp rollers.
	• Wheels pressure not adjusted correctly.	• Set both tire pressure to the correct pressure. (See TIRES on page 42.)
Blades scalping grass.	• Cutting height too low.	• Raise the cutting height.
	• Turning speed too fast.	• Reduce speed on turns.
	• Ridges in terrain.	• Change the mowing pattern.
	• Rough or uneven terrain.	• Adjust wheels pressure and anti-scalp rollers.
	• Anti-scalp rollers not adjusted correctly.	• Adjust wheels pressure and anti-scalp rollers.
	• Bent blade(s).	• Replace blade(s).
Excessive vibration.	• Debris on mower deck or in pulleys.	• Clean the mower deck and pulleys.
	• Damaged mower belt.	• Replace the mower belt.
	• Damaged pulleys.	• Replace pulleys.
	• Pulleys out of alignment.	• Check pulleys.
	• Blades out of balance.	• Have blades balanced.
Mower loads down machine.	• Engine rpm too low.	• Mow at full throttle, check and reset the engine rpm.

(Continued)

## TROUBLESHOOTING

Symptom (if)	Cause	Remedy
Mower loads down machine.	• Ground speed too fast.	• Slow down.
	• Debris wrapped around mower spindles.	• Clean the mower.
	• Front of deck too low.	• Adjust the mower deck. (See MOWER DECK LEVEL on page 80.)

If you have any questions, contact your local KUBOTA Dealer.

# ENGINE EMISSION RELATED INFORMATION

The KGZ770-MA1 engine conforms to U.S. EPA and California emission regulations for off-road large or small SI engines.

- Emission compliance period: 1000 HOURS
- CARB emissions durability period: EXTENDED

**Catalytic muffler**

The WG972-G engine must use KUBOTA catalytic muffler (EG806-1211-0).

**Carburetor (KGZ770-MA1)**



The carburetor is tamper resistant; the idle mixture screw has been covered by tamper plug after adjustment at the factory.

You cannot adjust this screw.

**High altitude operation**

**IMPORTANT :**

- **Altitude compensation kit is applied for EPA and CARB certified engines only.**  
**EPA and CARB emission regulations require the ultimate users of non-road SI engine, as their obligation, to adjust the emissions by installing the appropriate genuine altitude compensation kit. And the engine manufacturer must provide such a kit when the engine is operated at an altitude that exceeds the standard level, as guaranteed by the engine manufacturer. For this purpose, KUBOTA has prepared a genuine altitude compensation kit described below. The ultimate users of SI engines must comply with the regulations through the proper installation of the appropriate altitude compensation kit for the altitude range where the engine will be operated.**

Altitude compensation kit	Applicable altitude ranges
Original carburetor (with 0 m kit)*1	 0 to 1000 m (0 to 3300 ft)
1500 m compensation carburetor kit	 500 to 2500 m (1600 to 8200 ft)

\*1 If you have lost the original carburetor kit, buy the 0 m kit. Altitude compensation kit part number: consult your local KUBOTA Dealer and specify your engine type and engine serial number. Consult your local KUBOTA Dealer for further information on the altitude compensation kit.

Consult your local KUBOTA Dealer for further information on this procedure.



# INDEX

## A

air cleaner primary element	
cleaning.....	60
replacing.....	73
air intake area	
checking.....	53
cleaning.....	53
anti-scalp rollers	
adjusting.....	80
area around battery	
cleaning.....	68
area around engine	
checking.....	54
cleaning.....	54

## B

battery	
charging.....	67
checking condition.....	66
jump starting.....	27
troubleshooting.....	90
blades	
checking.....	76
replacing.....	76
bonnet screen	
checking.....	53
cleaning.....	53
bottom dust cover	
checking.....	54
cleaning.....	54
brake spring	
checking.....	65

## C

choke knob.....	24
Cleaning combustion chamber.....	73
cold weather	
starting engine.....	27
cutting height	
adjusting.....	38
cutting height reference chart.....	40

## D

daily check	
checking fuel level .....	52
checking movable parts.....	56
checking the engine oil level.....	51
checking the tire pressure.....	42,55
checking the tire pressure (warning information)..	55
refueling.....	52
daily check list.....	51

## E

Easy Checker™ indicators.....	26
engine	
check during operating.....	26
jump starting.....	27
starting.....	23
starting in cold weather.....	27
starting information.....	25
stop (by manual).....	25
stopping.....	25
troubleshooting.....	88
warming up.....	27
engine break-in.....	29
engine breather hose	
checking.....	74
replacing.....	75
engine emission related information.....	93
engine oil	
changing.....	60
engine oil cooler fins	
cleaning.....	62
engine oil filter	
replacing.....	69
engine shroud	
cleaning.....	71
engine shroud panel	
cleaning.....	61
engine start system	
checking.....	56
engine valve clearance	
adjusting.....	73

## F

front caster wheels	
installing.....	43
removing.....	42
front side.....	50
fuel.....	47
fuel filter	
checking.....	63
replacing.....	73
fuel filter bowl	
cleaning.....	64,86
inspecting.....	86
fuel gauge.....	26
fuel lines	
checking.....	63,73
replacing.....	75
fuel pump.....	26
fuel system	
bleeding.....	77
fuses	
replacing.....	75

<b>G</b>	
gear box oil	
changing.....	68
gear box oil level	
checking.....	57
grease fittings	
lubricating.....	55,58
<b>H</b>	
hand controls.....	19
hood.....	49
hour meter.....	26
hydraulic hose	
checking.....	73
hydraulic hoses	
replacing.....	75
hydraulic lift control pedal.....	32
hydraulic oil filter	
replacing.....	72
<b>I</b>	
implement limitations.....	18
instrument panel.....	19
intake air line	
checking.....	74
replacing.....	75
<b>K</b>	
key switch.....	25
<b>L</b>	
lever guide	
opening.....	50
lift-up point.....	50
lubricants.....	47
<b>M</b>	
machine	
before operating.....	5
fuel treatment.....	85
getting off.....	23
getting on.....	23
operating on slopes.....	7
parking.....	36
removing from storage.....	85
servicing.....	8,15
specification table.....	16
starting.....	31,41
starting to operate.....	6
stopping.....	8,36
storing.....	10,85
transporting.....	8,36
troubleshooting.....	90
working.....	6
machine (new)	
changing engine oil.....	29
changing lubricating oil.....	29
changing oil filter cartridge.....	29
changing transaxle fluid.....	29
operating.....	29
operating warning.....	29
motion control lever.....	33
adjusting (warning information).....	78
adjusting HST neutral.....	78
adjusting maximum speed (forward).....	79
aligning.....	79
alignment.....	79
checking the alignment.....	79
operating position.....	34
stop position.....	33
motion control lever neutral position.....	78
motion control lever pivot	
adjusting.....	71
mower	
adjusting.....	22
operating.....	41
troubleshooting.....	91
type.....	20
mower belt	
replacing.....	77
mower deck	
dismounting.....	22
front-to-rear leveling.....	81
mounting.....	21
side-to-side leveling.....	80
mower gear box oil seal	
checking.....	74
mower gear box oil-seal	
replacing.....	75
mowing tips.....	38
<b>O</b>	
oiling.....	59
one way valve	
replacing.....	75
OPC system	
checking.....	57
operator's seat.....	31
lowering.....	49
raising.....	49
<b>P</b>	
parking brake	
adjusting.....	65
applying.....	23
releasing.....	23
parking brake pedal.....	33
periodic service chart label.....	46
PTO	
using.....	8
PTO lever.....	41

## R

rear axle gear case oil (RH and LH)	
changing.....	71
rear side.....	51
ROPS (foldable type)	
adjusting.....	31
folding.....	30
operating.....	30
raising to the upright position.....	31

## S

safety	
before operating the machine.....	5
general information.....	5
operating on slopes.....	7
ROPS.....	6
servicing the machine.....	8
starting to operate the machine.....	6
stopping the machine.....	8
storing the machine.....	10
transporting the machine.....	8
using the lift link.....	8
working the machine.....	6
safety for children.....	7
safety for operators (age 60 years and older).....	7
safety labels.....	11
care.....	14
seat belt.....	32
secondary element	
replacing.....	73
service intervals.....	44
slope	
checking.....	66
restarting.....	35
spark plug	
condition check.....	70
gap check.....	70
step	
opening.....	49
switches.....	19

## T

throttle cable	
adjusting.....	68
throttle lever.....	24,33
torque general specification.....	83
torque tightening chart.....	84
transmission fluid	
changing.....	71
transmission fluid level	
checking.....	53
transmission oil	
warming up in the low temperature range.....	27
transmission oil filter (HST)	
replacing.....	70

## W

wheels.....	42
work light (optional kit).....	37